

NQ/NQM Panelboards and QONQ Load Centers

Class 1640
80043-712-06, Rev. 09

What’s in This Document

- Safety Information 1
- Introduction 3
- Installation 5
 - Circuit Breaker Restrictions 16
- Appendix 1: Specifications..... 18
- Appendix 2: Accessory Kits 38

Safety Information

Read these instructions carefully and examine the equipment to become familiar with the device before attempting to install, operate, service, or maintain it. The following special messages may appear throughout this user guide or on the equipment to warn of hazards or to call attention to information that clarifies or simplifies a procedure.

Schneider Electric
800 Federal Street
Andover, MA 01810
USA
888-778-2733

www.se.com

As standards, specifications, and design change from time to time, please ask for confirmation of the information given in this publication.
© 2024 – 2026 Schneider Electric. All rights reserved.





The addition of either symbol to a “Danger” or “Warning” safety label indicates that an electrical hazard exists which will result in personal injury if the instructions are not followed.



This is the safety alert symbol. It is used to alert you to personal injury hazards. Obey all safety messages that follow this symbol to avoid possible injury or death.

DANGER

DANGER indicates a hazardous situation which, if not avoided, **will result in** death or serious injury.

WARNING

WARNING indicates a hazardous situation which, if not avoided, **could result in** death or serious injury.

CAUTION

CAUTION indicates a hazardous situation which, if not avoided, **could result in** minor or moderate injury.

NOTICE

NOTICE is used to address practices not related to physical injury.

NOTE: Provides additional information to clarify or simplify a procedure.

Please Note

Electrical equipment should be installed, operated, serviced, and maintained only by qualified personnel. No responsibility is assumed by Schneider Electric for any consequences arising out of the use of this material.

A qualified person is one who has skills and knowledge related to the construction, installation, and operation of electrical equipment and has received safety training to recognize and avoid the hazards involved.

Electrical equipment should be transported, stored, installed, and operated only in the environment for which it is designed.

Introduction

This bulletin contains instructions for installing Square D™ brand NQ circuit breaker panelboards and QONQ load centers. These panelboards and load centers are Underwriters Laboratories (cULus) listed and accept QO™ and QOB branch circuit breakers.

NOTE: For technical support on the installation of this panelboard, contact the Schneider Electric Customer Information Center at 1-888-778-2733.

NOTE: See the labels on the equipment for rating and safety information. Additional equipment labels are provided with this document.

Safety Precautions

DANGER

HAZARD OF ELECTRIC SHOCK, EXPLOSION, OR ARC FLASH

- Apply appropriate personal protective equipment (PPE) and follow safe electrical work practices. See NFPA 70E, NOM-029-STPS or CSA Z462 or local equivalent.
- This equipment must only be installed and serviced by qualified electrical personnel.
- Turn off all power supplying this equipment before working on or inside equipment.
- Always use a properly rated voltage sensing device to confirm power is off.
- Read and understand this entire instruction bulletin and the included NEMA PB 1.1 standards publication before installing, operating, or maintaining this equipment.
- Local codes vary, but are adopted and enforced to promote safe electrical installations. A permit may be needed to do electrical work, and some codes may require an inspection of the electrical work.
- Replace all devices, doors, and covers before turning on power to this equipment.
- Do not allow petroleum based paints, solvents, or sprays to contact the nonmetallic parts of this product.

Failure to follow these instructions will result in death or serious injury.



WARNING: This product can expose you to chemicals including Nickel compounds, which are known to the State of California to cause cancer, and Bisphenol A (BPA), which is known to the State of California to cause birth defects or other reproductive harm. For more information go to www.P65Warnings.ca.gov.

Installation

This section provides instructions for the following NQ panelboard and QONQ load center procedures:

- Interior Mounting for Square D Brand Enclosures, page 5.
- Neutral Bonding Strap/Cable Installation, page 8.
- QO and QOB Circuit Breaker Installation and Removal, page 12.
- Circuit Breaker Reset Instructions, page 15.
- Deadfront Preparation, page 17.

Interior Mounting for Square D Brand Enclosures

A separate standards publication, titled “General Instructions for Proper Installation, Operation, and Maintenance of Panelboards Rated 600 Volts or Less” (NEMA PB1.1), has been provided with this equipment. Familiarize yourself with the content of this document before proceeding with any of the following procedures.

If you did not receive a copy of this document, or if you have any questions regarding this equipment, contact your local distributor or Schneider Electric representative.

⚠ DANGER

HAZARD OF ELECTRIC SHOCK, EXPLOSION, OR ARC FLASH

- Ensure all field connections are properly tightened.
- Do not over torque or under torque connections. Refer to the torque information label provided on the panelboard before tightening connections.

Failure to follow these instructions will result in death or serious injury.

To properly mount and install the NQ panelboard or QONQ load center interior, please refer to the NEMA PB 1.1 standards publication, and follow the instructions below for either [Surface Mounting \(Enclosure](#)

Mounted on Wall), page 6 or Flush Mounting (Enclosure Recessed in Wall), page 6.

Surface Mounting (Enclosure Mounted on Wall)

1. Mount the enclosure as instructed in the NEMA PB 1.1 standards publication.
2. Remove the deadfront from the deadfront brackets.
3. Install the interior as described below:
 - a. Set the interior on the enclosure studs. An elevating screw is not required (See Interior Mounting for Square D Brand Enclosures, page 5).
 - b. Tighten the Keps nuts against the interior side rails until the rails are against the back of the enclosure.
4. Based on the application and adopted installation code, a Neutral Bonding Strap and Line Side Barrier may be required. See the Neutral Bonding Strap/Cable Installation, page 8 and Appendix 2: Accessory Kits, page 38.
5. Apply equipment labels (located in the bag assembly) as directed by the instructions on the back of the equipment label sheet. Please consult local codes and standards.
6. Remount the deadfront after wiring.

Flush Mounting (Enclosure Recessed in Wall)

1. Mount the enclosure as instructed in the NEMA PB 1.1 standards publication.
2. Remove the deadfront from the deadfront brackets.

3. Install the interior as described below:
 - a. Thread the (4) 10-32 x 0.875 in. self-tapping, elevating screws provided with the flush trim into the side rails.
 - b. Set the interior on the enclosure studs (see *Interior Mounting of Square D Brand Enclosures*, page 7). Place the keps nuts onto the enclosure studs, but do not tighten.
 - c. Adjust the screws so that the lip of the deadfront is approximately 0.25 inches (6.35 mm) from the wall line.
 - d. Tighten the keps nuts against the side rails.
4. Based on the application and adopted installation code, a Neutral Bonding Strap and Line Side Barrier may be required. Please consult local codes and standards. See the *Neutral Bonding Strap/Cable Installation*, page 8 and *Appendix 2: Accessory Kits*, page 38.
5. Apply equipment labels (located in the bag assembly) as directed by the instructions on the back of the equipment label sheet.
6. Remount the deadfront after wiring.

Figure 1 - Interior Mounting in Square D Brand Enclosures

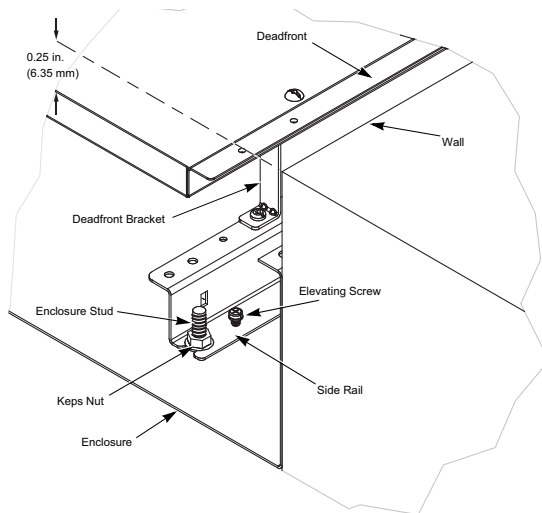

Neutral Bonding Strap/Cable Installation

Based on the application and the adopted installation code, a line side barrier and neutral bonding strap may be required.

To properly bond the neutral to the panelboard, follow the instructions for either 100 or 250 A Maximum NQ Panelboards, or 400 or 600 A Maximum NQ Panelboards and QONQ Load Centers, page 10.

⚠ DANGER

HAZARD OF ELECTRIC SHOCK, EXPLOSION, OR ARC FLASH

- Apply appropriate personal protective equipment (PPE) and follow safe electrical work practices. See NFPA 70E, NOM-029-STPS or CSA Z462 or local equivalent.
- Turn off all power supplying this equipment before working on or inside equipment.
- The neutral bonding strap/cable should be used only when the panelboard is installed as service entrance equipment.
- Do not mix the mounting screws with the deadfront screws.

Failure to follow these instructions will result in death or serious injury.

NOTE: Refer to Line Side Barrier and Neutral Bonding Strap Kits, page 41 for information.

NOTE: The terms “neutral bonding strap” and “neutral bonding cable”, describe the components which meet the requirements for a “neutral bonding conductor”. These are equivalent terms.

100 or 250 A Maximum NQ Panelboards

To install a neutral bonding strap on NQ panelboards with mains rated up to 225 A (with main lugs or main circuit breaker), or up to 250 A with a factory assembled main circuit breaker, refer to *Bonding Strap Installation—100 or 250 A Maximum NQ Panelboards*, page 10, and follow the instructions below.

1. Align the bonding strap on the side rail, as pictured.

NOTE: For some applications, it may be necessary to remove the lug (not pictured) before installing the bonding strap.

2. Insert the two mounting screws, as pictured. Tighten the 10-32 screw to 10–12 lb.-in. (1.1–1.4 N•m) and the 1/4-20 to 25–30 lb.-in. (2.8–3.4 N•m).

NOTE: Lug mounting screws are provided in the bonding strap bag assembly.

- a. If the lug was removed in step 1 above, reinstall it on top of the bonding strap. Tighten the 10-32 screw to 10–12 lb.-in. (1.1–1.4 N•m) and the 1/4-20 to 25–30 lb.-in. (2.8–3.4 N•m).
- b. Use 1/4-20 x 9/16 in. screw in mounting for 100/225 A interiors with no options. Refer to note C and D for other options.
- c. Use the 1/4-20 x 11/16 in. lug mounting screw on applications with feed-through lug, sub-feed lug, sub-feed circuit breaker, or 200% neutral applications.
- d. Use the 1/4-20 x 7/8 in. lug mounting screw on applications with 200% neutrals and with feed-through lugs, sub-feed lugs, or sub-feed circuit breakers.

Figure 2 - Bonding Strap Installation—100 or 250 A Maximum NQ Panelboards

NOTE: For bonding strap lug options, refer to C and D for the correct length of the 1/4-20 screw.

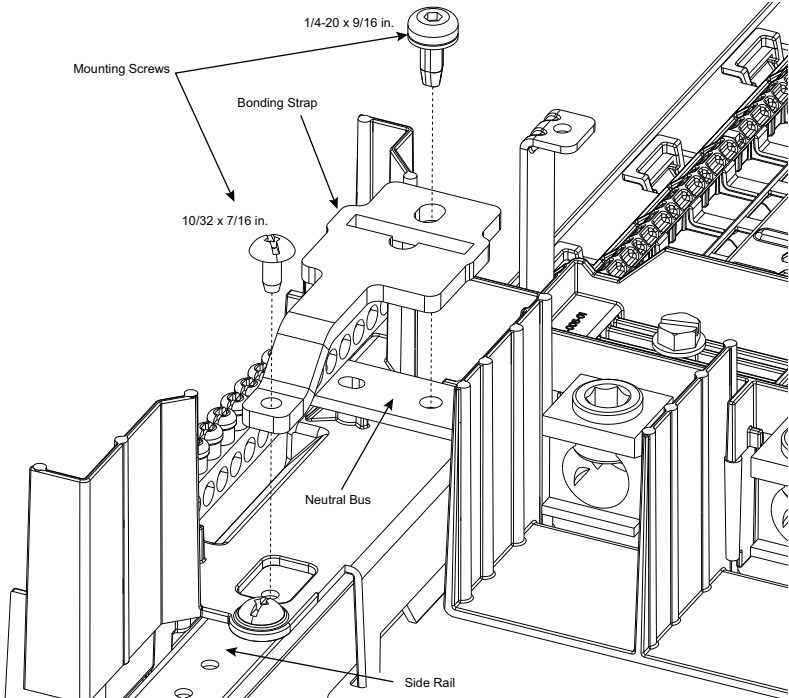

400 or 600 A Maximum NQ Panelboards and QONQ Load Centers

To install a neutral bonding cable on a 400 or 600 A maximum NQ panelboard and QONQ load center, refer to *Bonding Cable Installation — 400 or 600 A Maximum NQ Panelboards and QONQ Load Centers*, page 11, and follow the instructions below.

1. Align the lug on the side rail mounting hole, as pictured.

2. Tighten the lug mounting screw against the side rail to 10–12 lb.-in. (1.1–1.4 N•m).
3. Align the bonding cable, as pictured, and insert it into the lug and neutral mounting holes.
4. Tighten both the lug wire binding screw and the neutral wire binding screw to 45–50 lb.-in. (5.1–5.6 N•m).

Figure 3 - Bonding Cable Installation — 400 or 600 A Maximum NQ Panelboards and QONQ Load Centers

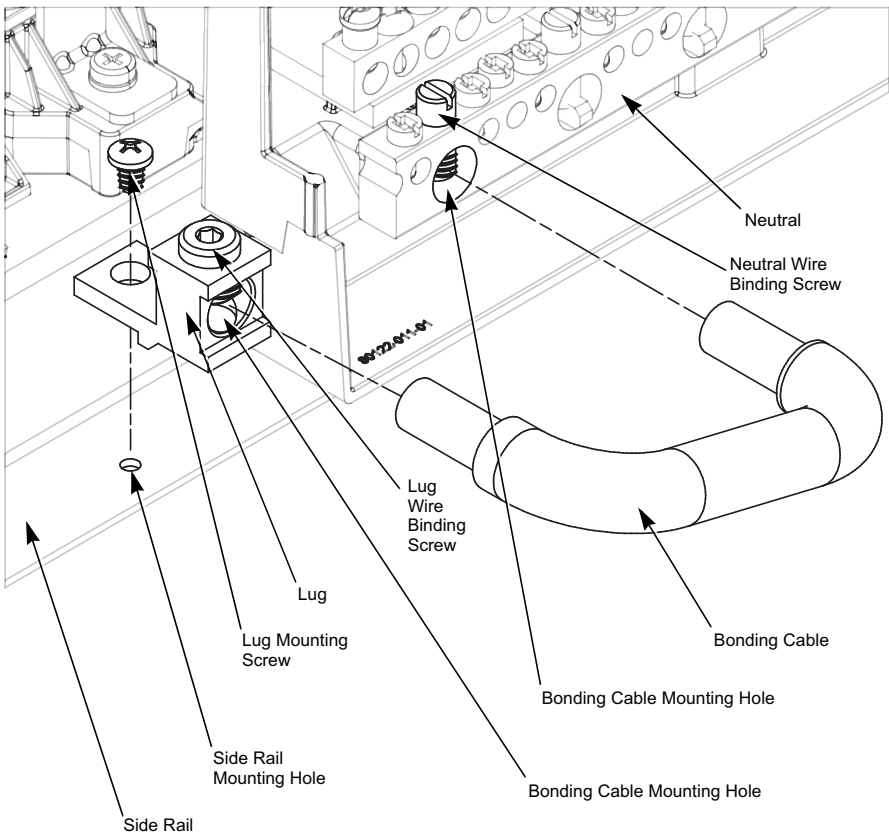

QO and QOB Circuit Breaker Installation and Removal

DANGER

HAZARD OF ELECTRIC SHOCK, EXPLOSION, OR ARC FLASH

- Apply appropriate personal protective equipment (PPE) and follow safe electrical work practices. See NFPA 70E, NOM-029-STPS or CSA Z462 or local equivalent.
- This equipment must only be installed and serviced by qualified electrical personnel.
- Turn off all power supplying this equipment before working on or inside equipment.
- Always use a properly rated voltage sensing device to confirm power is off.
- All unused spaces must be filled with filler plates.
- Replace all devices, doors, and covers before turning on power to this equipment.
- Use only Square D™ and Schneider Electric™ brand circuit breakers and accessories. This equipment is designed and tested by Schneider Electric to performance levels which meet applicable regulatory standards.
- Ensure all field connections are properly tightened.
- Do not over torque or under torque connections. Refer to the torque information label provided on the panelboard before tightening connections.

Failure to follow these instructions will result in death or serious injury.

QO and QOB Circuit Breaker Installation

Refer to QO and QOB Circuit Breaker Installation and Removal, page 14, for the following instructions:

1. Turn OFF all power to the panelboard.
2. Turn the circuit breaker OFF.
3. Remove the deadfront.
4. Snap the wire terminal end of the circuit breaker onto the mounting rail.
5. Engage the branch connector.

For QO Circuit Breakers: Push inward until the plug-on jaws fully engage the branch connector.

For QOB Circuit Breakers: Push inward until the circuit breaker connector is centered on the branch connector mounting hole. Engage the screw into the branch connector hole and tighten it to the torque values shown on the interior wiring and torque diagram.

6. Install the load wire.
7. Reinstall the deadfront.
8. Install a filler plate in all branch circuit breaker spaces not used.

QO and QOB Circuit Breaker Removal

Refer to QO and QOB Circuit Breaker Installation and Removal, page 14, for the following instructions:

1. Turn OFF all power to the panelboard.
2. Remove the deadfront.
3. Remove the load wire.
4. Disengage the branch connector.

For QO Circuit Breakers:

Pull outward until the plug-on jaws fully disengage the branch connector.

For QOB Circuit Breakers:

Loosen the screw in the circuit breaker connector and pull the circuit breaker off of the branch connector.

5. Remove the wire terminal end of the circuit breaker from the mounting rail.
6. Reinstall the deadfront.
7. Install a filler plate in all branch circuit breaker spaces not used.

Figure 4 - QO and QOB Circuit Breaker Installation and Removal

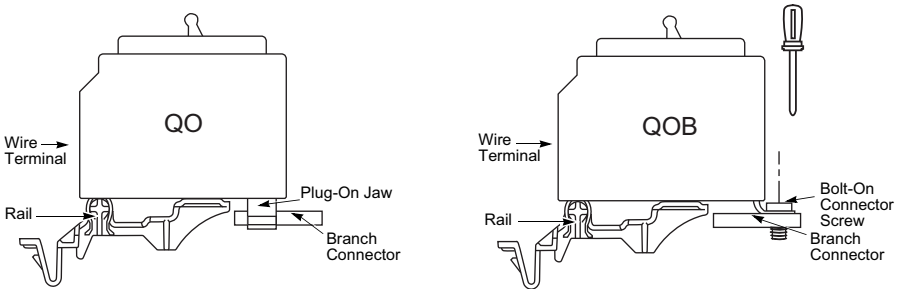

Circuit Breaker Reset Instructions

If the circuit breaker is tripped, the handle will be at the mid-position between ON and OFF. To reset the circuit breaker, push the handle to the OFF position, then to the ON position.

Figure 5 - Circuit Breaker Handle Positions

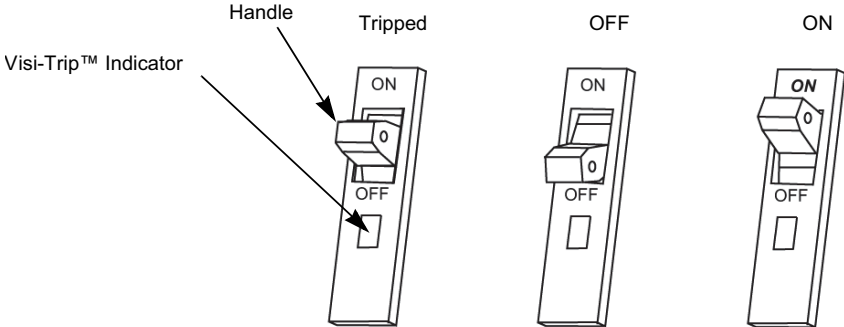

NOTE: When the circuit breaker has tripped, the handle assumes a center position and the red Visi-Trip indicator appears in a window in the circuit breaker case. The red Visi-Trip indicator is only visible when the circuit breaker has tripped.

Circuit Breaker Restrictions

Panel Type	Opposite Circuit Breaker Limit	Conditions
100 A	Combined rating ≤ 100 A	Applies to each branch bus connector
225 and 400 A	40 A max opposite 150 A two-pole or 110-150 A three-pole VH circuit breaker	OR 100 A max opposite 110-125 A two-pole VH circuit breaker
600 A	40 A max opposite 150 A two-pole or 110-150 A three-pole VH circuit breaker	OR 70 A max opposite 110-125 A two-pole VH circuit breaker
600 A (SPD only)	60 A max opposite 110 A, 125 and 150 A circuit breakers	Only if feeding Square D SPD equipment
600 A LD / LG / LJ / LL	Two 100 A circuit breakers cannot be installed opposite of another one	—
800 A	QO/QOB circuit breakers limited to 100 A max	Max config: one three-pole 100 A opposite another three-pole 100 A

For NQ panel applications in 14 in. wide enclosure, install 100 A maximum branch mounted circuit breakers.

Deadfront Preparation

⚠ DANGER

HAZARD OF ELECTRIC SHOCK, EXPLOSION, OR ARC FLASH

- Apply appropriate personal protective equipment (PPE) and follow safe electrical work practices. See NFPA 70E, NOM-029-STPS or CSA Z462 or local equivalent.
- Before energizing the panelboard, all unused spaces must be filled with filler plates.
- Replace all devices, doors, and covers before turning on power to this equipment.

Failure to follow these instructions will result in death or serious injury.

Figure 6 - Deadfront Diagram

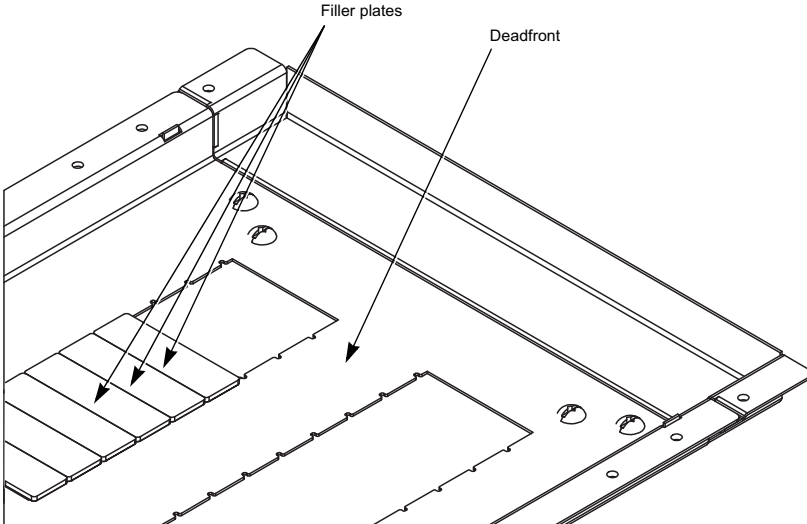

NOTE: The back of the deadfront lists the catalog number for the corresponding compatible filler plates.

Appendix 1: Specifications

Typical Wiring

Additional information is provided on the panelboard. See the main circuit breaker rating, if used.

Table 1 - Panelboard Typical Wiring

Voltage AC	1-Phase Panelboards		3-Phase Panelboards	
	Phase	Wires	Phase	Wires
208Y/120	—	—	3	4
120/240	1	3	—	—
240 ⁽¹⁾	1	2	3	4
240 ⁽²⁾	1	3	—	—
240/120 ⁽³⁾	—	—	3	4 Delta

- (1) For this system, the neutral is not used and only circuit breakers rated 240 Vac minimum should be used. Do not use circuit breakers rated 120 V or 120/240 Vac.
- (2) For a grounded "B" phase system, only circuit breakers rated 240 Vac minimum should be used. Do not use circuit breakers rated 120 V or 120/240 Vac.
- (3) When wiring for a delta system, phases "A" and "C" must be 120 V to neutral, phase "B" 208 V to neutral. Connect only circuit breakers rated 240 Vac minimum. Do not use circuit breakers rated 120 V or 120/240 V to "B" phase.

Integral Main or Sub-Feed

PowerPacT H-, J-, L-, and Q-Frame; LA, LH, QO(B)(VH)

Figure 7 - NQ/NQM 100–225 A Main Lugs or 100–250 A Main Circuit Breaker Diagram

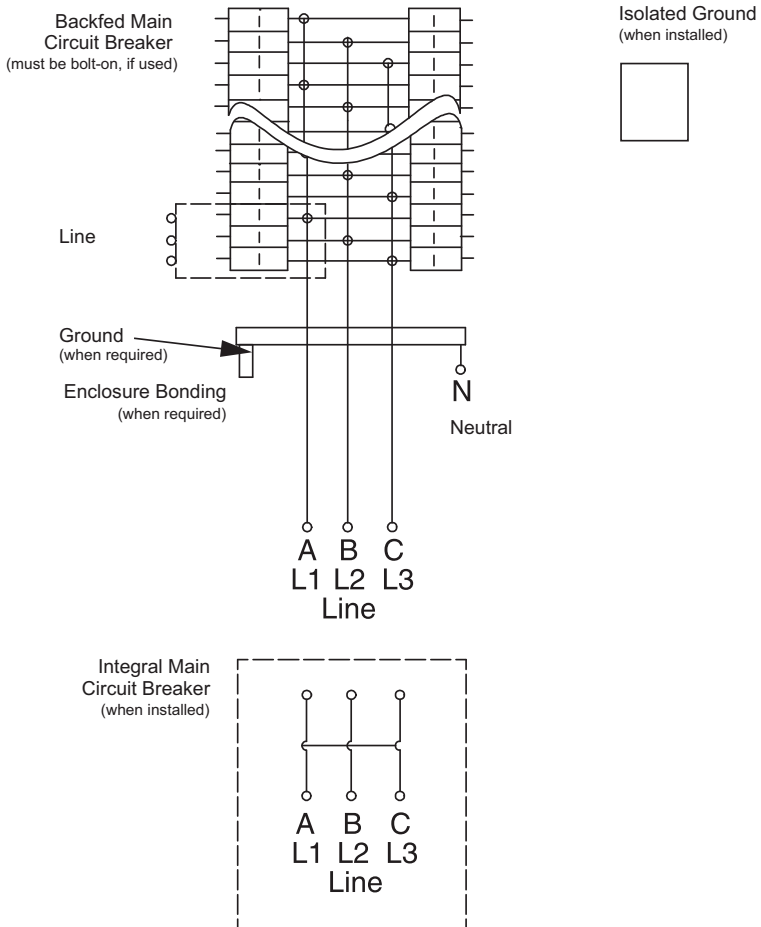

Figure 8 - NQ Panelboard or QONQ Load Center 400–800 A Main Lugs or Main Circuit Breaker with or without Feed-Through Lugs Diagram

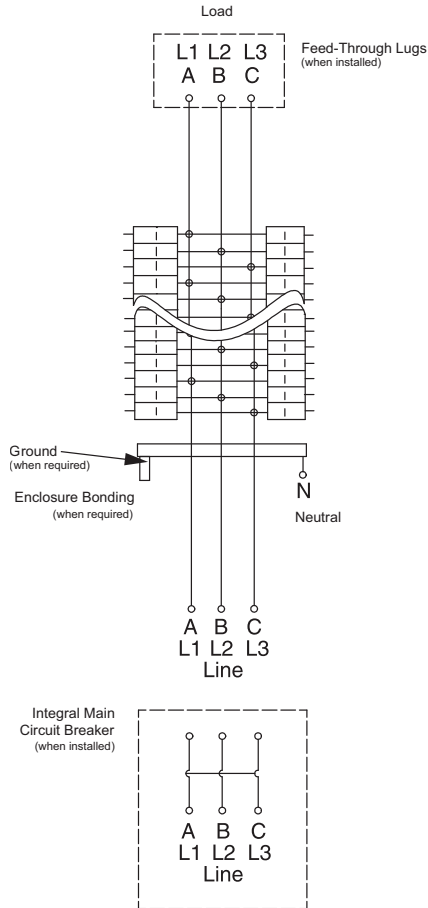

Figure 9 - NQ Panelboard or QONQ Load Center 400–600 A Main Circuit Breaker with Feed-Through Lugs or Sub-Feed Circuit Breakers

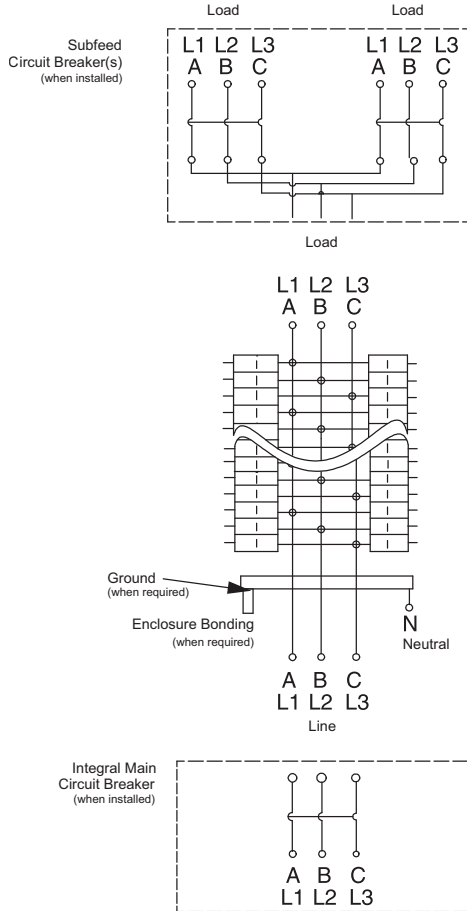
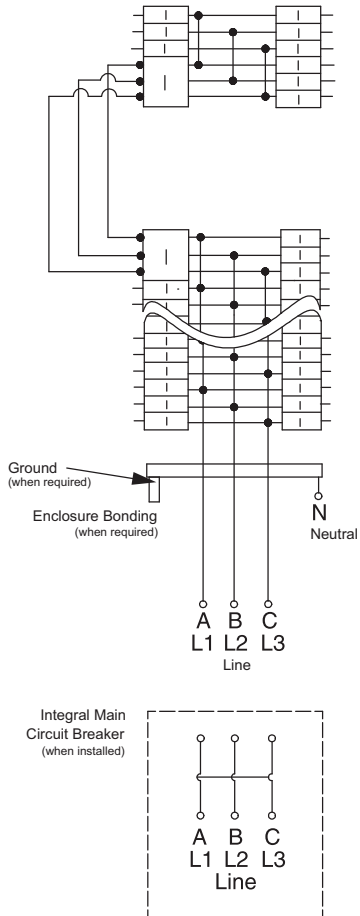

Figure 10 - Typical NQ Panelboard with Split Bus Diagram



Suitable for use on 48 Vdc Maximum Systems

For use on 48 Vdc Maximum Ungrounded Systems Only. Use only Type QO(B), 2 pole, 10–60 A branch, or branch fed main, circuit breakers with suffix 5272 that are rated for 48 Vdc maximum. Short Circuit Current Rating is limited to 5 kA when used on a 48 Vdc system.

For vertically mounted main and sub-feed circuit breakers use only H-, J-, and LA/LH-Frame circuit breakers. Short Circuit Current Rating is limited to 20 kA (H-, J-Frame), 10 kA (LA-Frame), and 50 kA (LH-Frame) when used on a 48 Vdc system.

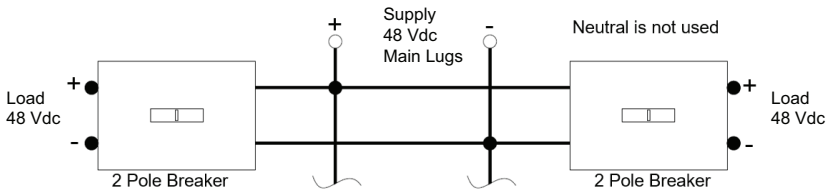

Panelboard Ratings

Refer to local codes and standards for more information. The series rated system label is located in the bag assembly.

Series Connected Circuit Breaker Ratings (RMS Symmetrical)

- Series Ratings listed at higher system voltages apply to lower system voltages (Example: 240 3P/3W covers 208Y/120 3P/4W).
- Short circuit tests are conducted at 100–105% of the maximum rated voltage of the panelboard.
- “MC” denotes Mission Critical circuit breakers.
- Where LG is shown, LJ and LL can be used.
- Unless otherwise noted, main circuit breakers can be applied at the maximum available amperage rating.
- Suffixes HID, SWD, and SWN may also be applied to the applicable branch circuit breakers shown below.
- Where QO(B) circuit breakers are shown below, QO(B)H, QO(B)VH, and QH(B) circuit breakers may also be used.
- Two-pole CAFI circuit breakers cannot be used on three-phase systems.

Table 2 - Max. System Voltage AC: 120/240 1P/3W, 208Y/120 3P/4W, 240/120 3P/4W

Max. Short Circuit Current Rating	Square D Brand Integral or Remote Main Circuit Breakers and Remote Main Fuses	Square D Brand Branch Circuit Breaker Catalog Designation and Allowable Ampere Ranges			
		Type	1-Pole	2-Pole	3-Pole
18,000	LA/LH MC	QO(B)	15–30 A	15–30 A	—
22,000	QO(B) VH QOB-VH	QO(B)	15–70 A	15–125 A	—
		QO(B) GFI	15–30 A	15–60 A	—
		QO(B) EPD	15–30 A	15–60 A	—
		QO(B) PL	15–30 A	15–60 A	—
		QO(B) AFI	15–20 A	—	—
		QO(B) CAFI	15–20 A	15–20 A	—
		QO(B) DF	15–20 A	—	—
25,000	QD	QO(B)	15–70 A	15–125 A	—
		QOB-VH	—	150 A	—
		QO(B) PL	15–30 A	15–60 A	—
		QO(B) GFI	15–30 A	15–60 A	—
		QO(B) EPD	15–30 A	15–60 A	—
		QO(B) AFI	15–20 A	—	—
		QO(B) CAFI	15–20 A	15–20 A	—
	QO(B) DF	15–20 A	—	—	
	ED	QO(B)	15–70 A	15–125 A	—
		QO(B) GFI	15–30 A	15–60 A	—
		QO(B) EPD	15–30 A	15–60 A	—
		QO(B) AFI	15–20 A	—	—
		QO(B) CAFI	15–20 A	15–20 A	—
		QO(B) DF	15–20 A	—	—
	BD, HD, JD, LG	QO(B)	15–70 A	15–125 A	—
		QOB-VH	—	150 A	—
		QO(B) PL	15–30 A	15–60 A	—
		QO(B) GFI	15–30 A	15–60 A	—
		QO(B) EPD	15–30 A	15–60 A	—
		QO(B) AFI	15–20 A	—	—
		QO(B) CAFI	15–20 A	15–20 A	—
BD, HD, JD, LG	QO(B) DF	15–20 A	—	—	
	QO(B) DF	15–20 A	—	—	
42,000	LA, MA	QO(B)	15–30 A	15–30 A	—

Table 2 - Max. System Voltage AC: 120/240 1P/3W, 208Y/120 3P/4W, 240/120 3P/4W (Continued)

Max. Short Circuit Current Rating	Square D Brand Integral or Remote Main Circuit Breakers and Remote Main Fuses	Square D Brand Branch Circuit Breaker Catalog Designation and Allowable Ampere Ranges			
		Type	1-Pole	2-Pole	3-Pole
65,000	QG	QO(B)	15–70 A	15–125 A	—
		QO(B) VH	15–70 A	15–125 A	—
		QOB-VH	—	150 A	—
		QO(B) GFI	15–30 A	15–60 A	—
		QO(B) PL	15–30 A	15–60 A	—
		QO(B) AFI	15–20 A	—	—
		QO(B) CAFI	15–20 A	15–20 A	—
		QO(B) DF	15–20 A	—	—
	EG	QO(B)	15–70 A	15–125 A	—
	EG	QO(B) GFI	15–30 A	15–60 A	—
		QO(B) EPD	15–30 A	15–60 A	—
		QO(B) EPE	—	—	—
		QO(B) AFI	15–20 A	—	—
		QO(B) CAFI	15–20 A	15–20 A	—
		QO(B) DF	15–20 A	—	—
	BG, HG, JG, LG	QO(B)	15–70 A	15–125 A	—
		QOB-VH	—	150 A	—
		QO(B) PL	15–30 A	15–60 A	—
		QO(B) GFI	15–30 A	15–60 A	—
		QO(B) EPD	15–30 A	15–60 A	—
		QO(B) AFI	15–20 A	—	—
		QO(B) CAFI	15–20 A	15–20 A	—
		QO(B) DF	15–20 A	—	—
	LL	QO(B) PL	—	15–60 A	—
		QO(B) GFI	15–30 A	40–60 A	—
		QO(B) EPD	15–30 A	—	—

Table 2 - Max. System Voltage AC: 120/240 1P/3W, 208Y/120 3P/4W, 240/120 3P/4W (Continued)

Max. Short Circuit Current Rating	Square D Brand Integral or Remote Main Circuit Breakers and Remote Main Fuses	Square D Brand Branch Circuit Breaker Catalog Designation and Allowable Ampere Ranges			
		Type	1-Pole	2-Pole	3-Pole
100,000	QJ	QO(B)	15–70 A	15–125 A	—
		QOB-VH	—	150 A	—
		QO(B) PL	15–30 A	15–60 A	—
		QO(B) GFI	15–30 A	15–60 A	—
		QO(B) EPD	15–30 A	15–60 A	—
		QO(B) AFI	15–20 A	—	—
		QO(B) CAFI	15–20 A	15–20 A	—
		QO(B) DF	15–20 A	—	—
	EJ	QO(B)	15–70 A	15–125 A	—
		QO(B) GFI	15–30 A	15–60 A	—
	EJ	QO(B) EPD	15–30 A	15–60 A	—
		QO(B) AFI	15–20 A	—	—
		QO(B) CAFI	15–20 A	15–20 A	—
		QO(B) DF	15–20 A	—	—
	BJ, HJ, JJ	QO(B)	15–70 A	15–125 A	—
		QOB-VH	—	150 A	—
		QO(B) PL	15–30 A	15–60 A	—
		QO(B) GFI	15–30 A	15–60 A	—
		QO(B) EPD	15–30 A	15–60 A	—
		QO(B) AFI	15–20 A	—	—
		QO(B) CAFI	15–20 A	15–20 A	—
		QO(B) DF	15–20 A	—	—
	LJ, LL	QO(B)	15–70 A	15–125 A	—
		QOB-VH	—	150 A	—
		QO(B) GFI	—	15–60 A	—
		QO(B) EPD	—	15–60 A	—
		QO(B) AFI	15–20 A	—	—
		QO(B) CAFI	15–20 A	15–20 A	—
QO(B) DF		15–20 A	—	—	
QO(B) PL		15–30 A	—	—	

Table 2 - Max. System Voltage AC: 120/240 1P/3W, 208Y/120 3P/4W, 240/120 3P/4W (Continued)

Max. Short Circuit Current Rating	Square D Brand Integral or Remote Main Circuit Breakers and Remote Main Fuses	Square D Brand Branch Circuit Breaker Catalog Designation and Allowable Ampere Ranges			
		Type	1-Pole	2-Pole	3-Pole
125,000	HL, JL	QO(B)	15–70 A	15–125 A	—
		QOB-VH	—	150 A	—
		QO(B) PL	15–30 A	15–60 A	—
		QO(B) GFI	15–30 A	15–60 A	—
		QO(B) EPD	15–30 A	15–60 A	—
		QO(B) AFI	15–20 A	—	—
		QO(B) CAFI	15–20 A	15–20 A	—
		QO(B) DF	15–20 A	—	—
200,000	HR, JR	QO(B)	15–70 A	15–125 A	—
		QO(B) GFI	15–30 A	15–60 A	—
		QO(B) EPD	15–30 A	15–60 A	—
		QO(B) AFI	15–20 A	—	—
	HR, JR	QO(B) CAFI	15–20 A	15–20 A	—
		QO(B) DF	15–20 A	—	—

Table 3 - Max. System Voltage AC: 240 1P/2W

Max. Short Circuit Current Rating	Square D Brand Integral or Remote Main Circuit Breakers and Remote Main Fuses	Square D Brand Branch Circuit Breaker Catalog Designation and Allowable Ampere Ranges			
		Type	1-Pole	2-Pole	3-Pole
25,000	QD, BD, HD, JD, LG	QO(B) H	—	15–100 A	—
42,000	LA, MA	QDL	—	70–225 A	—
65,000	QG, BG, HG, JG, LG	QO(B) H	—	15–100 A	—
100,000	BJ, HJ, JJ, LJ, LL	QO(B) H	—	15–100 A	—
125,000	HL, JL	QO(B) H	—	15–100 A	—

Table 4 - Max. System Voltage AC: 208Y/120 3P/4W

Max. Short Circuit Current Rating	Square D Brand Integral or Remote Main Circuit Breakers and Remote Main Fuses	Square D Brand Branch Circuit Breaker Catalog Designation and Allowable Ampere Ranges			
		Type	1-Pole	2-Pole	3-Pole
18,000	LA/LH MC	QO(B)	—	—	15–30 A
22,000	QO(B) VH, QOB-VH	QO(B) GFI	—	—	15–50 A

Table 4 - Max. System Voltage AC: 208Y/120 3P/4W (Continued)

Max. Short Circuit Current Rating	Square D Brand Integral or Remote Main Circuit Breakers and Remote Main Fuses	Square D Brand Branch Circuit Breaker Catalog Designation and Allowable Ampere Ranges			
		Type	1-Pole	2-Pole	3-Pole
25,000	QD, ED, FD, BD, HD, JD	QO(B) GFI	—	—	15–50 A
	LG	QO(B) GFI	—	—	15–30 A
65,000	QG, EG, BG, HG, JG	QO(B) GFI	—	—	15–50 A
	LG, LL	QO(B) GFI	—	—	15–30 A
100,000	QJ	QO(B)	—	—	15–30 A
		QO(B) VH	—	—	15–100 A
		QOB-VH	—	—	110–150 A
		QO(B) PL	—	—	15–30 A
		QO(B) GFI	—	—	15–50 A
		QO(B) EPD	—	—	15–50 A
	QO(B) EPE	—	—	15–50 A	
	EJ, BJ, HJ, JJ	QO(B) GFI	—	—	15–50 A
125,000	HJ, JL, LL	QO(B) GFI	—	—	15–50 A

Table 5 - Max. System Voltage AC: 240/120 3P/4W, 240 3P/3W

Max. Short Circuit Current Rating	Square D Brand Integral or Remote Main Circuit Breakers and Remote Main Fuses	Square D Brand Branch Circuit Breaker Catalog Designation and Allowable Ampere Ranges			
		Type	1-Pole	2-Pole	3-Pole
22,000	QOB VH QOB-VH	QO(B)	—	—	15–100 A
		QO(B) EPD	—	—	15–50 A
		QO(B) EPE	—	—	15–50 A
25,000	QD	QO(B)	—	—	15–30 A
	QD	QO(B) VH	—	—	15–100 A
		QOB-VH	—	—	110–150 A
		QO(B) PL	—	—	15–30 A
		QO(B) EPD	—	—	15–50 A
		QO(B) EPE	—	—	15–50 A
	ED	QO(B)	—	—	15–100 A
		QO(B) EPD	—	—	15–50 A
		QO(B) EPE	—	—	15–50 A
	BD, HD, JD	QO(B)	—	—	15–100 A
		QOB-VH	—	—	110–150 A
		QO(B) PL	—	—	15–30 A
		QO(B) EPD	—	—	15–50 A
		QO(B) EPE	—	—	15–50 A
	LG	QO(B)	—	—	15–30 A
		QO(B) VH	—	—	15–100 A
		QOB-VH	—	—	110–150 A
		QO(B) EPD	—	—	15–30 A
		QO(B) EPE	—	—	15–30 A
	42,000	LA, MA	QDL	—	—
QO(B) VH			—	—	15–30 A
MG		QOB-VH	—	—	110–150 A

Table 5 - Max. System Voltage AC: 240/120 3P/4W, 240 3P/3W (Continued)

Max. Short Circuit Current Rating	Square D Brand Integral or Remote Main Circuit Breakers and Remote Main Fuses	Square D Brand Branch Circuit Breaker Catalog Designation and Allowable Ampere Ranges			
		Type	1-Pole	2-Pole	3-Pole
65,000	QG	QO(B)	—	—	15–30 A
		QO(B) VH	—	—	15–100 A
	QG	QOB-VH	—	—	110–150 A
		QO(B) PL	—	—	15–30 A
	EG	QO(B)	—	—	15–100 A
		QOB-VH	—	—	110–125 A
		QO(B) EPD	—	—	15–50 A
		QO(B) EPE	—	—	15–50 A
	BG, HG, JG	QO(B)	—	—	15–100 A
		QOB-VH	—	—	110–150 A
		QO(B) PL	—	—	15–30 A
		QO(B) EPD	—	—	15–50 A
		QO(B) EPE	—	—	15–50 A
	LG, LL	QO(B)	—	—	15–30 A
		QO(B) VH	—	—	15–100 A
		QOB-VH	—	—	110–150 A
		QO(B) EPD	—	—	15–30 A
		QO(B) EPE	—	—	15–30 A

Table 5 - Max. System Voltage AC: 240/120 3P/4W, 240 3P/3W (Continued)

Max. Short Circuit Current Rating	Square D Brand Integral or Remote Main Circuit Breakers and Remote Main Fuses	Square D Brand Branch Circuit Breaker Catalog Designation and Allowable Ampere Ranges			
		Type	1-Pole	2-Pole	3-Pole
100,000	FC, KC	QO(B)	—	—	15-100 A
		QO(B)	—	—	15-100 A
	EJ	QOB-VH	—	—	110-125 A
		QO(B) EPD	—	—	15-50 A
		QO(B) EPE	—	—	15-50 A
		QO(B)	—	—	15-100 A
	BJ, HJ, JJ	QOB-VH	—	—	110-150 A
		QO(B) PL	—	—	15-30 A
		QO(B) EPD	—	—	15-50 A
		QO(B) EPE	—	—	15-50 A
		QO(B)	—	—	15-30 A
	LJ, LL	QO(B) VH	—	—	15-100 A
		QOB-VH	—	—	110-150 A
QO(B)		—	—	15-100 A	
125,000	HL, JL	QO(B)	—	—	15-100 A
		QOB-VH	—	—	110-150 A
	HL, JL	QO(B) PL	—	—	15-30 A
		QO(B) EPD	—	—	15-50 A
		QO(B) EPE	—	—	15-50 A
200,000	HR, JR	QO(B)	—	—	15-100 A
		QOB-VH	—	—	110-150 A

Table 6 - Max. System Voltage AC: 120/240 1P/3W, 208Y/120 3P/4W, 240/120 3P/3W

Max. Short Circuit Current Rating	Square D Brand Integral or Remote Main Circuit Breakers and Remote Main Fuses	Square D Brand Branch Circuit Breaker Catalog Designation and Allowable Ampere Ranges			
		Type	1-Pole	2-Pole	3-Pole
42,000	400 A Max. Class T3 Fuses	QO(B) VH	15–70 A	15–125 A	—
65,000	400 A Max. Class J Fuses	QO(B) VH	15–70 A	15–125 A	—
		QO(B) AFI	15–20 A	—	—
		QO(B) CAFI	15–20 A	15–20 A	—
		QO(B) DF	15–20 A	—	—
	400 A Max. Class T6 Fuses	QO(B) VH	15–70 A	15–125 A	—
		QOB-VH	—	150 A	—
		QO(B) AFI	15–20 A	—	—
		QO(B) CAFI	15–20 A	15–20 A	—
100,000	200 A Max. Class T3 Fuses	QO(B)	15–70 A	15–125 A	—
		QO(B) GFI	15–30 A	15–60 A	—
		QO(B) EPD	15–30 A	15–60 A	—
		QO(B) AFI	15–20 A	—	—
		QO(B) CAFI	15–20 A	15–20 A	—
		QO(B) DF	15–20 A	—	—
200,000	200 A Max. Class T6 or J Fuses	QO(B)	15–70 A	15–125 A	—
		QO(B) GFI	15–30 A	15–60 A	—
		QO(B) EPD	15–30 A	15–60 A	—
	400 A Max. Class T3 Fuses	QO(B)	15–70 A	15–125 A	—
		QO(B) GFI	15–30 A	15–60 A	—
		QO(B) EPD	15–30 A	15–60 A	—

Table 7 - Max. System Voltage AC: 208Y/120 3P/4W

Max. Short Circuit Current Rating	Square D Brand Integral or Remote Main Circuit Breakers and Remote Main Fuses	Square D Brand Branch Circuit Breaker Catalog Designation and Allowable Ampere Ranges			
		Type	1-Pole	2-Pole	3-Pole
65,000	400 A Max. Class J	QO(B) GFI	—	—	15–50 A
100,000	200 A Max. Class T3	QO(B) GFI	—	—	15–50 A

Table 7 - Max. System Voltage AC: 208Y/120 3P/4W (Continued)

Max. Short Circuit Current Rating	Square D Brand Integral or Remote Main Circuit Breakers and Remote Main Fuses	Square D Brand Branch Circuit Breaker Catalog Designation and Allowable Ampere Ranges			
		Type	1-Pole	2-Pole	3-Pole
200,000	200 A Max. Class T6 or J Fuses	QO(B) GFI	—	—	15–50 A
	400 A Max. Class T3 Fuses	QO(B) GFI	—	—	15–50 A

Table 8 - Max. System Voltage AC: 240/120 3P/4W, 240 3P/3W

Max. Short Circuit Current Rating	Square D Brand Integral or Remote Main Circuit Breakers and Remote Main Fuses	Square D Brand Branch Circuit Breaker Catalog Designation and Allowable Ampere Ranges			
		Type	1-Pole	2-Pole	3-Pole
50,000	600 A Max. Class T3 Fuses	QO(B) VH	—	—	15–30 A
65,000	400 A Max. Class J Fuses 400 A Max. Class T6 Fuses	QO(B) VH	—	—	15–100 A
		QO(B) VH	—	—	15–100 A
		QOB-VH	—	—	110–150 A
100,000	200 A Max. Class T3 Fuses	QO(B)	—	—	15–100 A
		QO(B) EPD	—	—	15–50 A
		QO(B) EPE	—	—	15–50 A
200,000	200 A Max. Class T6 or J Fuses	QO(B)	—	—	15–100 A
		QO(B) EPD	—	—	15–50 A
		QO(B) EPE	—	—	15–50 A
	400 A Max. Class T3 Fuses	QO(B)	—	—	15–100 A
		QO(B) EPD	—	—	15–50 A
		QO(B) EPE	—	—	15–50 A

NOTE: In the following table, Type includes AFI, CAFI, EPD, and GFI Circuit Breakers.

Table 9 - NQ Panel Mission Critical Breaker Selectivity

Maximum SCCR (RMS Symmetrical)	Integral or Remote Main Circuit Breakers	Branch Circuit Breakers			
		Type	1-Pole	2-Pole	3-Pole
Fully Rated and Selective to 10 kA at 208Y/120 Vac or at 240/120 Vac	J-W, 250 A L-W, 250 A	QOB	10-70	10-125	10-125
		QOB-H			
		QOB-VH			
		QH			
Series Rated and Selective to 12 kA at 208Y/120 Vac or at 240/120 Vac	J-W, 250 A	QOB	10-70	10-125	10-60
		QOB-H			
		QOB-VH			
		QH			
Series Rated and Selective to 15 kA at 208Y/120 Vac or at 240/120 Vac	J-W, 250 A	QOB	10-60	10-60	10-30
		QOB-H			
		QOB-VH			
		QH			
Series Rated and Selective to 18 kA at 208Y/120 Vac or at 240/120 Vac	J-W, 250 A	QOB	10-30	10-30	—
		QOB-H			
		QOB-VH			
		QH			
	L-W, 250 A	QOB	10-60	10-60	10-60
		QOB-H			
		QOB-VH			
		QH			
Series Rated and Selective to 30 kA at 208Y/120 Vac or at 240/120 Vac	L-W, 400 A L-W, 600 A	QOB	15-70	15-150	15-150
		QOB-H			
		QOB-VH			
		QH			

Table 10 - Short Circuit Current Rating⁽⁴⁾ for Main Lug Interiors with Sub-Feed or Feed-Through Lugs

Maximum System Voltage AC	Maximum Current Rating	Branch Circuits	Application	Adder	Maximum Short Circuit Current Rating	
240	100	18, 30	SFL and FTL	—	10,000	
	225	30, 42, 54, 72, 84, 96	SFL	6 in. (152.4 mm)		
		42	FTL	—		
		30, 54, 72, 84, 96		6 in. (152.4 mm)		
	400	30, 42, 54, 72, 84	SFL	—	25,000	
				96	—	10,000
		30, 84	FTL	—	25,000	
				96	—	10,000
				42, 54, 72	6 in. (152.4 mm)	25,000
		600	30, 42, 54, 72, 84	FTL	12 in. (304.8 mm)	
			96			10,000

CE Marking

- Interiors with the “CE” mark meet the IEC 61439-1 and IEC 61439-2 standards.
- Main lug interiors with the “CE” mark have been tested to withstand 10,000 RMS symmetrical amperes for 30 cycles.
- Interiors with the “CE” mark are only approved for use with QOXD or QOBXD branch circuit breakers which carry the “CE” mark.

(4) This rating applies to main lug interiors, equipped with sub-feed or feed-through lugs, where the device feeding the interior is unknown or not a Square D brand device. Use of a Square D brand main circuit breaker ahead of these lugs will result in a rating equal to the rating of the circuit breaker. Short circuit tests are conducted at 100–105% of the maximum rated voltage of the panelboard.

(5) 96 circuits with SPD has 84 usable branch circuits.

(6) The adder is the additional length of the enclosure.

(7) RMS symmetrical amperes, for three cycles.

QO2150VH, QO2175VH and QO2200VH Restrictions

NOTICE

HAZARD OF EQUIPMENT DAMAGE

- Do not install QO2150(VH), QO2175(VH) or QO2200(VH) in seismic applications.
- Do not install QO2150(VH), QO2175(VH) or QO2200(VH) in three phase system applications.
- Do not install more than a total of four QO2175(VH) or QO2200(VH) on NEMA 1 enclosures.
- Do not install more than one QO2175(VH) or QO2200(VH) in NEMA 3R Vented Weatherproof enclosures.
- Do not install QO2150(VH), QO2175(VH) or QO2200(VH) adjacent to each other.
- Do not install in un-vented weatherproof enclosures (3R/5/12, 4/4X).
- For QO2175(VH) and QO2200(VH) circuit breakers install three-point latch trims.

Failure to follow these instructions can result in equipment damage.

Leave at least four circuit spaces of blank fillers or circuit breakers of 125 A or lower before another QO2150(VH), QO2175(VH) or QO2200(VH) is installed.

Place QO2150(VH), QO2175(VH) and QO2200(VH) next to line end, on the right side for top incoming applications.

Place QO2150(VH), QO2175(VH) and QO2200(VH) next to line end, on the left side for bottom incoming applications.

QO2150(VH), QO2175(VH) and QO2200(VH) for single phase applications only.

Table 11 - Three-Point Latch Trim Fronts—Catalog Number⁽⁸⁾

Type	Surface Mounted	Flush Mounted
Standard	NC50VS3P	NC50VF3P
	NC56VS3P	NC50VF3P
	NC62VS3P	NC62VF3P
	NC68VS3P	NC68VF3P
	NC74VS3P	NC74VF3P
	NC80VS3P	NC80VF3P
	NC86VS3P	NC86VF3P
	NC92VS3P	NC92VF3P
Hinged	NC62VS3PHR	NC62VF3PHR
	NC68VS3PHR	NC68VF3PHR
	NC74VS3PHR	NC74VF3PHR
	NC80VS3PHR	NC80VF3PHR
	NC86VS3PHR	NC86VF3PHR
	NC92VS3PHR	NC92VF3PHR

Figure 11 - Three-Point Latch Trim Front

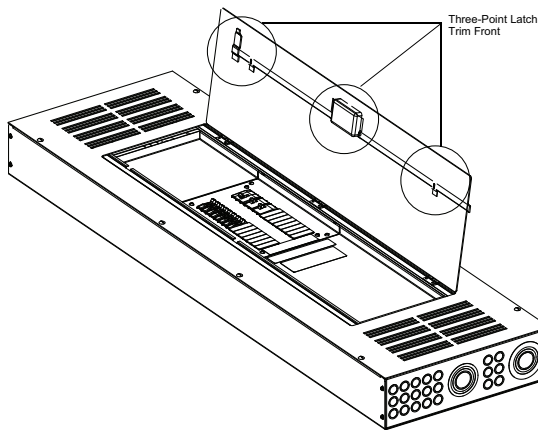

⁽⁸⁾ V=Vented, HR=Hinged Right, 3P=Three Point.

Appendix 2: Accessory Kits

An assortment of field-installable accessory kits are available for NQ panelboards:

- Equipment Ground Bar Kits
- Oversized Neutral Lug Kits for 100–600 A Panelboards
- Sub-Feed Lug Kits for 100–400 A Panelboards
- Main Lug Kits
 - Mechanical Lug Kits—Aluminum
 - Mechanical Lug Kits—Copper
 - Versa-Crimp Compression Lug Kits—Aluminum
 - Versa-Crimp Compression Lug Kits—Copper
- Line Side Barrier and Neutral Bonding Strap Kits

Equipment Ground Bar Kits

Equipment ground bar kits, suitable for copper or aluminum wire, meet the grounding needs of NQ panelboards and QONQ load centers.

Table 12 - Equipment Ground Bar Kits Specifications

Panelboard		Use Ground Bar Kit Catalog Number	
Branch Circuit	Mains Rating	Aluminum	Copper
1–42	600 A Maximum	(1) PK27GTA	(1) PK27GTACU
54–84		(2) PK27GTA	(2) PK27GTACU
54–72	800 A Maximum	(2) PK23GTAL	(2) QO1150AN



Ground bar mounting locations are identified by the ground symbol stamped into the back wall of the enclosure.

(9) Aluminum bars suitable for 60°C or 75°C Copper or Aluminum conductors.
 (10) Copper bars suitable for 60°C or 75°C Copper conductors.

Oversized Neutral Lug Kits for 100–600 A Panelboards

Oversized neutral lug kits are available for applications where termination conductors of 3 AWG or larger are required for the neutral.

Table 13 - Oversized Neutral Lug Kits for 100–600 A Panelboard Specifications

Circuit Breaker Rating	Kit Catalog Number	Wire Size Al/Cu (mm ²)
70 A	QO70AN	(1) #12–#2 AWG Al ([1] 3.3–33.6) (1) #14–#4 AWG Cu ([1] 2.1–21.2)
80–100 A	NQ100AN	(1) #14–2/0 AWG Al/Cu ([1] 2.1–67.4)
80–120 A	Q1100AN	(1) #4–1/0 AWG Al/Cu ([1] 21.2–53.5)
110–150 A	Q1150AN ⁽¹¹⁾	(1) #1–2/0 AWG Al/Cu ([1] 42.4–67.4)
175–200 A	NQ200AN	(1) #4 AWG–300 kcmil Al/Cu ([1] 21.2–152)

Sub-Feed Lug Kits for 100–400 A Panelboards

Sub-feed main lugs are available for 100, 225, or 400 A applications.

Table 14 - Sub-Feed Lug Kits for 100–400 A Panelboards Specifications

Main Amps	Kit Catalog Number	Maximum Circuits
100	NQSFL1	18, 30
225	NQSFL2	30 ⁽¹²⁾ , 42 ⁽¹²⁾ , 54 ⁽¹²⁾ , 72 ⁽¹²⁾ , 84 ⁽¹²⁾
400	NQSFL4	30, 42, 54, 72, 84

⁽¹¹⁾ Use Only use 1/0 (53.5 mm²) copper wire for 150 A branch circuit breaker applications.

⁽¹²⁾ These panels require an additional 6 inches (152.4 mm) for the box and trim, for proper wire bending space.

Main Lug Kits

Table 15 - Mechanical Lug Kits — Aluminum

Panelboard Amps	Kit Catalog Number	Wire Size Al/Cu (mm ²)
100	Standard	#6–2/0 AWG (13.3–67.43 mm ²)
225	Standard	#6 AWG–350 kcmil (13.3–177.3 mm ²)
400	Standard	(1) 1/0 AWG–750 kcmil (2) 1/0 AWG–350 kcmil ([1] 53.48–380 mm ²) ([2] 53.48–177.3 mm ²)
		(2) 1/0 AWG–750 kcmil (2) 53.48–380 mm ²)
600	Standard	(2) 1/0 AWG–750 kcmil (2) 53.48–380 mm ²)
	NQALM6A	(3) #6 AWG–250 kcmil ([3] 13.3–127 mm ²)

Table 16 - Mechanical Lug Kits — Copper

Panelboard Amps	Kit Catalog Number	Wire Size Al/Cu (mm ²)
100	NQCUM1	#6–2/0 AWG (13.3–67.43 mm ²)
225	NQCUM2	#6 AWG–250 kcmil (13.3–127 mm ²)
400	NQCUM4	(1) 1/0 AWG–750 kcmil (2) 1/0 AWG–350 kcmil ([1] 53.48–380 mm ²) ([2] 53.48–177.3 mm ²)
600	NQCUM6	

Table 17 - Versa-Crimp™ Compression Lug Kits — Aluminum

Panelboard Amps	Kit Catalog Number	Wire Size Al/Cu (mm ²)	Crimp Tool
100	NQALV1	#8–1/0 AWG (8.36–53.48 mm ²)	VC6 (All)
225	NQALV2	#4 AWG–300 kcmil (21.15–152 mm ²)	
400	NQALV4	(2) 2/0 AWG–500 kcmil ([2] 67.43–253.4 mm ²)	VC6–3, VC6–FT
600	NQALV6		

Table 18 - Versa-Crimp™ Compression Lug Kits — Copper

Panelboard Amps	Kit Catalog Number	Wire Size Al/Cu (mm ²)	Crimp Tool
100	NQCUV1	#6–1/0 AWG (13.30–53.48 mm ²)	VC6 (All), VC7 (All)
225	NQCUV2	2/0 AWG–300 kcmil (67.43–152 mm ²)	VC6-3, VC7, VC6-FT, VC7-FT
400	NQCUV4	400–750 kcmil (202.7–380 mm ²)	VC6-FT, VC7–FT, VC8
600	NQCUV6	(2) 250–500 kcm ([2] 126.7–253.4 mm ²)	VC6-3, VC7, VC6-FT, VC7-FT

Line Side Barrier and Neutral Bonding Strap Kits

Based on the application and the adopted installation code, a Line Side Barrier and Neutral Bonding Strap may be required. Select the appropriate barrier from the table below, based upon the main circuit breaker.

Table 19 - Line Side Barrier and Neutral Bonding Strap Kits

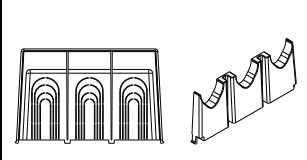
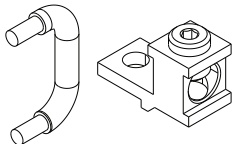
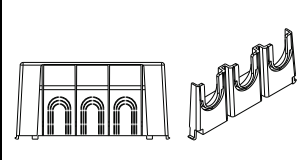
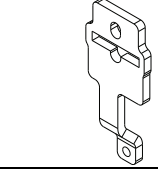
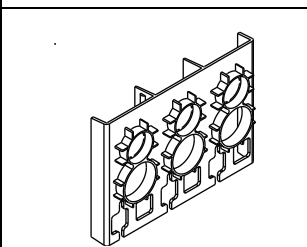
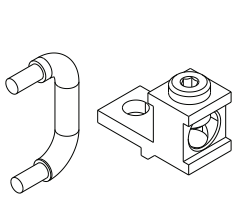
Catalog Number	Contents		Description
	Line Lug Cover	Neutral Bonding Strap	
NQLALLC			NQ LA/LH Line Lug Cover and Neutral Bonding Strap and Lug
NQHJQLLC			NQ PowerPac™ H/J/Q Line Lug Cover and Neutral Bonding Strap
NQPPLLLC			PowerPac™ L Line Lug Cover and Neutral Bonding Strap and Lug

