

Easy Series

EasyPact MVS1 Circuit Breakers With TS Trip System and Switch-Disconnectors From 630 to 1600 A

User Guide

Easy Series offers essential and accessible value devices.

DOCA0297EN-02
12/2024



Legal Information

The information provided in this document contains general descriptions, technical characteristics and/or recommendations related to products/solutions.

This document is not intended as a substitute for a detailed study or operational and site-specific development or schematic plan. It is not to be used for determining suitability or reliability of the products/solutions for specific user applications. It is the duty of any such user to perform or have any professional expert of its choice (integrator, specifier or the like) perform the appropriate and comprehensive risk analysis, evaluation and testing of the products/solutions with respect to the relevant specific application or use thereof.

The Schneider Electric brand and any trademarks of Schneider Electric SE and its subsidiaries referred to in this document are the property of Schneider Electric SE or its subsidiaries. All other brands may be trademarks of their respective owner.

This document and its content are protected under applicable copyright laws and provided for informative use only. No part of this document may be reproduced or transmitted in any form or by any means (electronic, mechanical, photocopying, recording, or otherwise), for any purpose, without the prior written permission of Schneider Electric.

Schneider Electric does not grant any right or license for commercial use of the document or its content, except for a non-exclusive and personal license to consult it on an "as is" basis.

Schneider Electric reserves the right to make changes or updates with respect to or in the content of this document or the format thereof, at any time without notice.

To the extent permitted by applicable law, no responsibility or liability is assumed by Schneider Electric and its subsidiaries for any errors or omissions in the informational content of this document, as well as any non-intended use or misuse of the content thereof.

Table of Contents

| | |
|---|----|
| Safety Information | 5 |
| Safety Notice | 6 |
| Cybersecurity Safety Notice | 6 |
| About the Book | 7 |
| EasyPact MVS1 Description | 8 |
| Easy Series Master Range | 9 |
| EasyPact MVS1 Range | 10 |
| Fixed Device | 11 |
| Drawout Device | 14 |
| Device Identification | 20 |
| Go2SE Landing Page | 23 |
| Operating Conditions | 25 |
| Schneider Electric Green Premium™ Ecolabel | 27 |
| EasyPact MVS1 Normal Operation | 30 |
| Device Operating Actions | 31 |
| Operating the Device | 32 |
| Opening the Device | 36 |
| Closing the Device | 37 |
| Resetting the Device | 38 |
| Operating Accessories | 39 |
| Drawout Device Racking Actions | 41 |
| Drawout EasyPact MVS1 Device Status | 42 |
| Disconnecting the Drawout Device | 45 |
| Connecting the Drawout Device | 47 |
| Removing the Drawout Device | 49 |
| Installing the Drawout Device in the Chassis | 52 |
| Device Locking Actions | 54 |
| Locking the Pushbuttons | 55 |
| Locking the Device in Open Position with Keylocks | 57 |
| Chassis Locking in Disconnected Position | 60 |
| Chassis Locking in Any Position | 65 |
| Locking the Safety Shutters | 70 |
| Device Interlocking Actions | 71 |
| VPEC Door Interlock | 72 |
| VPOC Open-door Racking Interlock | 75 |
| Mechanical Interlocking for Transfer Switches | 77 |
| EasyPact MVS Critical Cases | 79 |
| Finding the Cause of a Trip or an Alarm in Critical Cases | 80 |
| Resetting the Circuit Breaker After a Trip Due to an Electrical Fault | 82 |
| Resetting the Circuit Breaker After a Trip Due to an Incident Detected by | |
| TS Self-tests | 85 |
| Diagnosing Alarms | 86 |
| EasyPact MVS Commissioning | 88 |
| Introduction to Commissioning | 89 |
| Inspection and TS Settings | 91 |
| Tests | 93 |
| Final Checks and Reporting | 97 |

| | |
|--|------------|
| EasyPact MVS Test Form..... | 98 |
| EasyPact MVS Troubleshooting | 101 |
| Introduction to Troubleshooting..... | 102 |
| Troubleshooting: Chassis Operation | 103 |
| Troubleshooting: Unexpected Tripping | 104 |
| Troubleshooting: Mechanical Control Operations | 105 |
| Troubleshooting: Electrical Control Operations | 106 |

Safety Information

Important Information

Read these instructions carefully, and look at the equipment to become familiar with the device before trying to install, operate, service, or maintain it. The following special messages may appear throughout this documentation or on the equipment to warn of potential hazards or to call attention to information that clarifies or simplifies a procedure.



The addition of this symbol to a "Danger" or "Warning" safety label indicates that an electrical hazard exists which will result in personal injury if the instructions are not followed.



This is the safety alert symbol. It is used to alert you to potential personal injury hazards. Obey all safety messages that follow this symbol to avoid possible injury or death.

⚠ DANGER

DANGER indicates a hazardous situation which, if not avoided, **will result in** death or serious injury.

⚠ WARNING

WARNING indicates a hazardous situation which, if not avoided, **could result in** death or serious injury.

⚠ CAUTION

CAUTION indicates a hazardous situation which, if not avoided, **could result in** minor or moderate injury.

NOTICE

NOTICE is used to address practices not related to physical injury.

Please Note

Electrical equipment should be installed, operated, serviced, and maintained only by qualified personnel. No responsibility is assumed by Schneider Electric for any consequences arising out of the use of this material.

A qualified person is one who has skills and knowledge related to the construction and operation of electrical equipment and its installation, and has received safety training to recognize and avoid the hazards involved.

Safety Notice

DANGER

HAZARD OF ELECTRIC SHOCK, EXPLOSION, OR ARC FLASH

- Apply appropriate personal protective equipment (PPE) and follow safe electrical work practices. See NFPA 70E, CSA Z462, NOM 029-STPS or local equivalent.
- This equipment must only be installed and serviced by qualified electrical personnel.
- Turn off all power supplying this equipment before working on or inside this equipment.
- Always use a properly rated voltage sensing device to confirm power is off.
- Put back all devices, doors, and covers before turning on power to this equipment.
- Beware of potential hazards, and carefully inspect the work area for tools and objects that may have been left inside the equipment.

Failure to follow these instructions will result in death or serious injury.

Cybersecurity Safety Notice

WARNING

POTENTIAL COMPROMISE OF SYSTEM AVAILABILITY, INTEGRITY, AND CONFIDENTIALITY

- Change default passwords at first use to help prevent unauthorized access to device settings, controls, and information.
- Disable unused ports/services and default accounts to help minimize pathways for malicious attackers.
- Place networked devices behind multiple layers of cyber defenses (such as firewalls, network segmentation, and network intrusion detection and protection).
- Use cybersecurity best practices (for example, least privilege, separation of duties) to help prevent unauthorized exposure, loss, modification of data and logs, or interruption of services.

Failure to follow these instructions can result in death, serious injury, or equipment damage.

About the Book

Document Scope

The aim of this guide is to provide users, installers, and maintenance personnel with technical information needed to operate EasyPact™ MVS1 circuit breakers with TS trip systems in compliance with the IEC standards.

Validity Note

This guide applies to EasyPact MVS1 circuit breakers with TS trip systems:

- With firmware version 004.029.048 or greater
- With hardware version 001.000.000 or greater

Online Information

The information contained in this guide is likely to be updated at any time. Schneider Electric strongly recommends that you have the most recent and up-to-date version available on www.se.com/ww/en/download.

The technical characteristics of the devices described in this guide also appear online. To access the information online, go to the Schneider Electric home page at www.se.com.

Related Documents

| Title of documentation | Reference number |
|--|--------------------------|
| <i>EasyPact MVS - TS Trip System - User Guide</i> | DOCA0299EN DOCA0299ZH |
| <i>EasyPact MVS IEC Circuit Breakers with ETA and ETV Trip Systems From 630 to 4000 A - User Guide</i> | MVS21734 |
| <i>EasyPact MVS - TS Trip System - Firmware Release Notes</i> | DOCA0315EN |
| <i>EasyPact MVS Fixed or Drawout Circuit Breaker or Switch-Disconnectors - Instruction Sheet</i> | S1B70236 |

You can download these technical publications and other technical information from our website at www.se.com/ww/en/download/.

Information on Non-Inclusive or Insensitive Terminology

As a responsible, inclusive company, Schneider Electric is constantly updating its communications and products that contain non-inclusive or insensitive terminology. However, despite these efforts, our content may still contain terms that are deemed inappropriate by some customers.

Trademarks

QR Code is a registered trademark of DENSO WAVE INCORPORATED in Japan and other countries.

EasyPact MVS1 Description

What's in This Part

| | |
|--|----|
| Easy Series Master Range..... | 9 |
| EasyPact MVS1 Range | 10 |
| Fixed Device..... | 11 |
| Drawout Device..... | 14 |
| Device Identification | 20 |
| Go2SE Landing Page | 23 |
| Operating Conditions..... | 25 |
| Schneider Electric Green Premium™ Ecolabel | 27 |

Easy Series Master Range

Easy Series delivers a range of energy management and industrial automation products that focus on core features to meet the needs of the customers at a value price. The Easy Series products are intuitive to set up and ride. The series includes essential product lines such as circuit breakers, UPS, metering, motion and drives, human-machine interface, PLC, and push buttons.

EasyPact MVS1 Range

The EasyPact MVS1 range is made of:

- Circuit breakers with TS Trip System and switch-disconnectors, described in this guide.
- Circuit breakers with ET, ETA and ETV Trip Systems, described in *MVS21734 EasyPact MVS IEC Circuit Breakers with ET, ETA and ETV Trip System From 630 to 4000 A – User Guide*.

Convention

This guide applies to EasyPact MVS1 circuit breakers and switch-disconnectors.

EasyPact MVS1 Circuit Breakers with TS Trip Systems

The range of EasyPact MVS1 circuit breakers with TS trip system offers current ratings from 630 to 1600 A, for AC power systems up to 440 Vac. The range is covered by one frame size.

EasyPact MVS1 circuit breakers with TS trip system are available:

- In the following power systems:
 - 3-pole (3P)
 - 4-pole (4P)
- In the following installation types:
 - Fixed-mounted devices
 - Drawout devices

For information about TS trip system, refer to DOCA0299●● *EasyPact MVS - TS Trip System - User Guide*, page 7.

EasyPact MVS1 Circuit Breakers Performances

EasyPact MVS1 circuit breakers with TS trip system are available with the following performance level:

- C: high short-circuit level (66 kA) with high selectivity (50 kA) network
NOTE: The values above correspond to a 440 Vac network, for higher voltage levels the values can be different.

EasyPact MVS1 Switch-Disconnecter Performances

The switch-disconnector functions in the CA performance level ($I_{cw} = 50 \text{ kA/1s}$).

Neutral Position on 4P Devices

On 4P devices, the neutral is on the left side as standard. A right side neutral version is not available for circuit breakers.

Fixed Device

Fixed Device Description

The following image shows the standard version of the fixed device (no optional accessories).

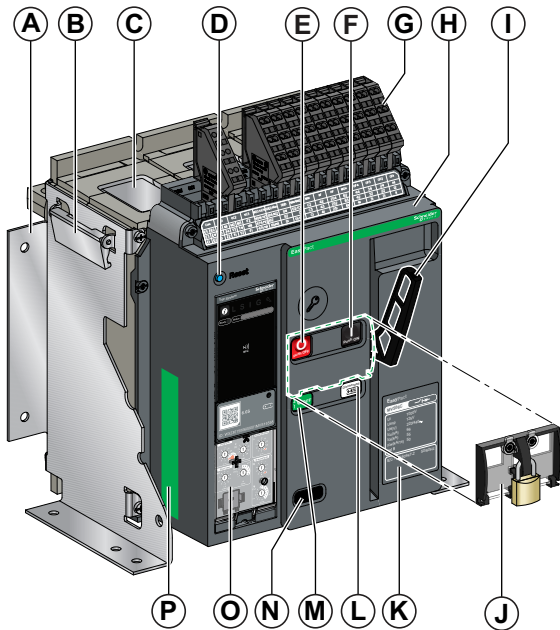

- A** Mounting side plate
- B** Carrying handle
- C** Arc chute
- D** Blue fault-trip reset button
- E** Opening pushbutton
- F** Closing pushbutton
- G** Terminal blocks for standard accessories
- H** Front cover
- I** Spring charging handle
- J** VBP pushbutton locking cover (optional)
- K** Rating plate
- L** Spring charged and ready-to-close indicator
- M** Main-contact position indicator
- N** Window to read the optional CDM mechanical operation counter
- O** Trip system
- P** Product identification label with manufacturing date

Fixed Device Accessories Description

The following image shows the accessories available for the fixed device.

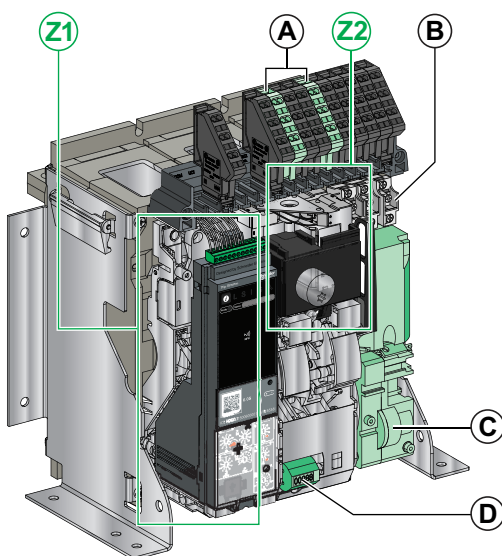

- A** Terminal blocks for optional accessories (optional)
- B** Four OF indication contacts (standard)
- C** MCH gear motor (standard)
- D** CDM mechanical operation counter (optional)
- Z1, Z2** See following images

The following images zoom in on the accessories for the fixed device:

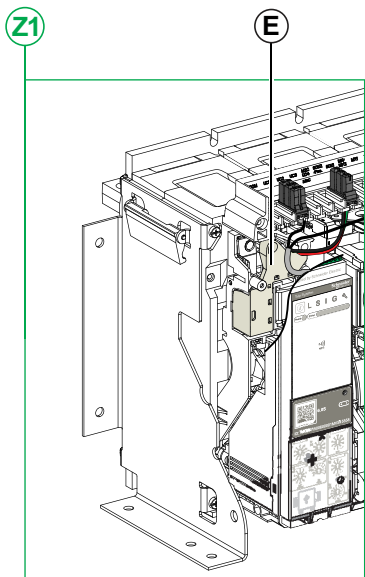

E Standard SDE1 fault-trip indication contact

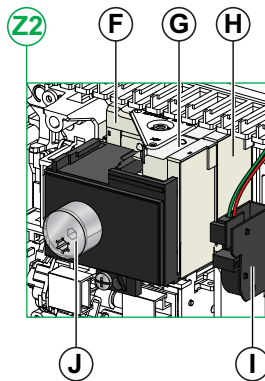

F MN undervoltage release or MX2 opening voltage release (optional)

G XF closing voltage release (standard)

H MX1 opening voltage release (standard)

I PF ready-to-close contact (optional)

J VSPO OFF-position locking by keylocks (optional)

Fixed Device Terminal Block Description

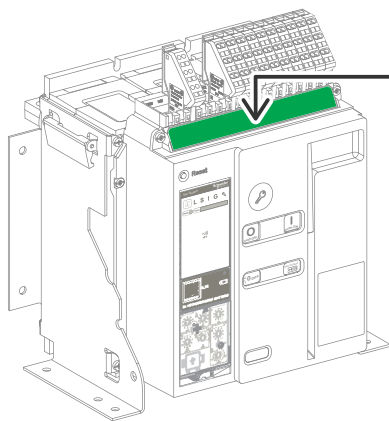

| COM | UC1 | UC2 | UC3 | M2/UC4 | SDE2/Res | SDE1 | MN/MX2 | MX1 | XF | PF | MCH | OF4 | OF3 | OF2 | OF1 | | | |
|-----|-----|-----|-----|--------|----------|------|--------|--------|----|--------|-----|-----|-----|-----|-----|----|----|----|
| E5 | E6 | Z5 | M1 | M2 | M3 | F2 | 484/V3 | 184/K2 | 84 | D2/C12 | C2 | A2 | 254 | B2 | 44 | 34 | 24 | 14 |
| E3 | E4 | Z3 | Z4 | T3 | T4 | VN | 474/V2 | 182 | 82 | C13 | C3 | A3 | 252 | B3 | 42 | 32 | 22 | 12 |
| E1 | E2 | Z1 | Z2 | T1 | T2 | F1 | 471/V1 | 181/K1 | 81 | D1/C11 | C1 | A1 | 251 | B1 | 41 | 31 | 21 | 11 |



Terminal block supplied as standard on the device



Terminal block supplied as standard on the device with TS 6.0S trip system



Terminal block for optional accessories on the device



Terminal block not used on the device

Assignment of Terminal Blocks

⚡ **! DANGER**

HAZARD OF ELECTROCUTION FOR VOLTAGES ABOVE 480 VAC

If voltage greater than 480 Vac is connected to a terminal, it is forbidden to connect adjacent terminals to a 24 Vdc SELV (Safety Extra Low Voltage) power supply in order to observe the insulation distances.

Failure to follow these instructions will result in death or serious injury.

The following table describes the assignment and the availability of the terminal blocks for fixed devices:

- Standard terminal blocks and the associated accessories are delivered with the device.
- Optional terminal blocks are delivered with the device only if the associated optional accessories are installed in the device.
- N/A indicates that the terminal blocks and the associated optional accessories are not compatible with the device.

| Marking | Description | Device |
|----------|---|---|
| COM | Not used | Not used |
| UC1 | Not used | Not used |
| UC2 | Neutral external sensor | Standard on devices with TS 6.0S trip system Not used on devices with TS 2.0, 5.0, 2.0S, or 5.0S trip system |
| UC3 | Not used | Not used |
| SDE2/RES | Not used | Not used |
| M2C/UC4 | Not used | Not used |
| SDE1 | SDE1 fault-trip indication contact | Standard |
| MN/MX2 | MN undervoltage release or MX2 opening voltage release | Optional |
| MX1 | MX1 opening voltage release | Standard |
| XF | XF closing voltage release | Standard |
| PF | PF ready-to-close contact | Optional |
| MCH | MCH gear motor | Standard |
| OF1-OF4 | 4 OF indication contacts | Standard |

Drawout Device

Definition

A drawout device is composed of the moving part (also called the device) and the fixed part (or chassis).

Drawout Device Moving Part Description

The following image shows the standard version of the moving part of a drawout device (no optional accessories).

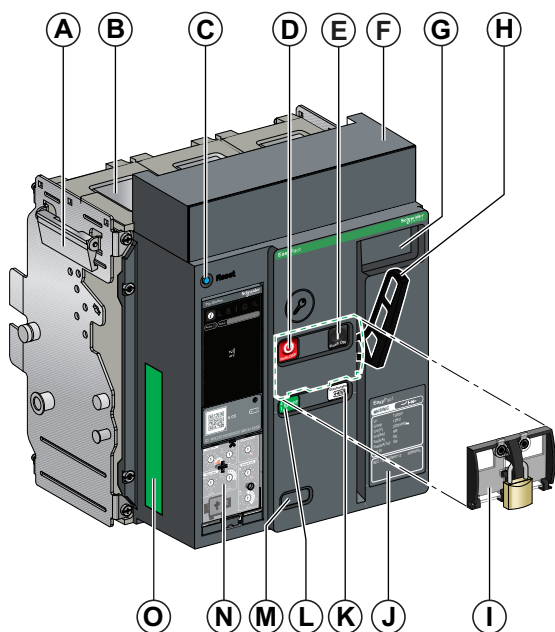

- A** Carrying handle
- B** Arc chute
- C** Blue fault-trip reset button
- D** Opening pushbutton
- E** Closing pushbutton
- F** Disconnectable contact block cover
- G** Front cover
- H** Spring charging handle
- I** VBP pushbutton locking cover (optional)
- J** Rating plate
- K** Spring charged and ready-to-close indicator
- L** Main-contact position indicator
- M** Window to consult the optional CDM mechanical operation counter
- N** Trip system
- O** Product identification label, with manufacturing label

Drawout Device Accessories Description

The following image shows the accessories available for the moving part of a drawout device.

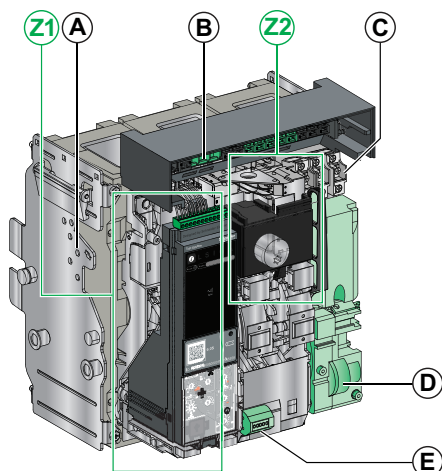

- A** VDC mismatch protection (optional)
- B** Disconnectable contact block
- C** Four OF indication contacts (standard)
- D** MCH gear motor (standard)
- E** CDM mechanical operation counter (optional)
- Z1, Z2** See following images

The following images zoom in on the accessories for the moving part of a drawout device.

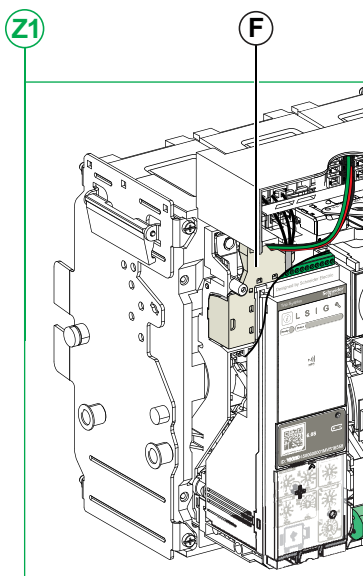

F Standard SDE1 fault-trip indication contact

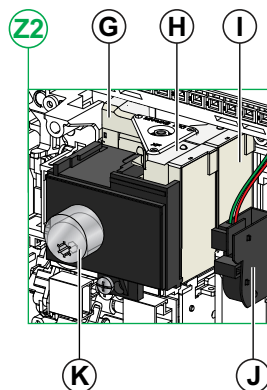

G MN undervoltage release or MX2 opening voltage release (optional)

H XF closing voltage release (standard)

I MX1 opening voltage release (standard)

J PF ready-to-close contact (optional)

K VSPO OFF-position locking by keylocks (optional)

Chassis Description

The following image shows the standard version of the chassis (no optional accessories).

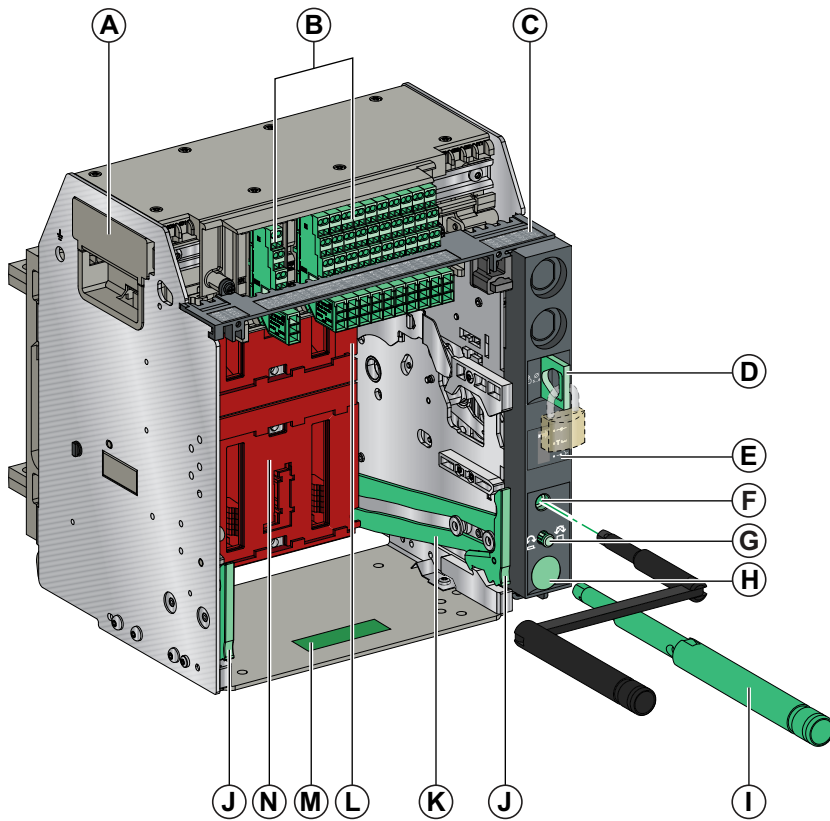

- | | |
|---|---|
| A Carrying grip | I Racking handle |
| B Terminal blocks for standard accessories | J Drawout grip |
| C Terminal block identification plate | K Extension rail |
| D Chassis locking by padlocks | L Top safety shutter |
| E Position indicator | M Product identification label with manufacturing date |
| F Racking handle socket | N Bottom safety shutter |
| G Position release button | |
| H Racking handle storage space | |

Chassis Accessories Description

The following image shows the accessories available for the chassis.

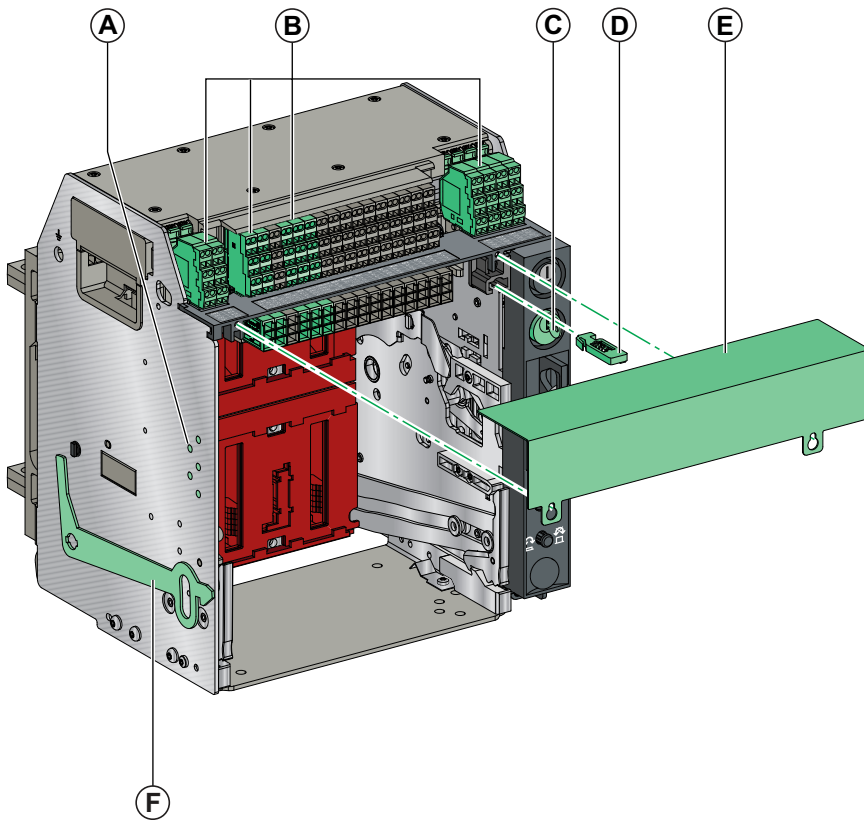

A VDC mismatch protection

B Terminal blocks for optional accessories

C VSPD chassis locking by keylocks

D VPOC open-door racking interlock

E Device auxiliary terminal shield

F VPEC door interlock

Chassis Terminal Block Description

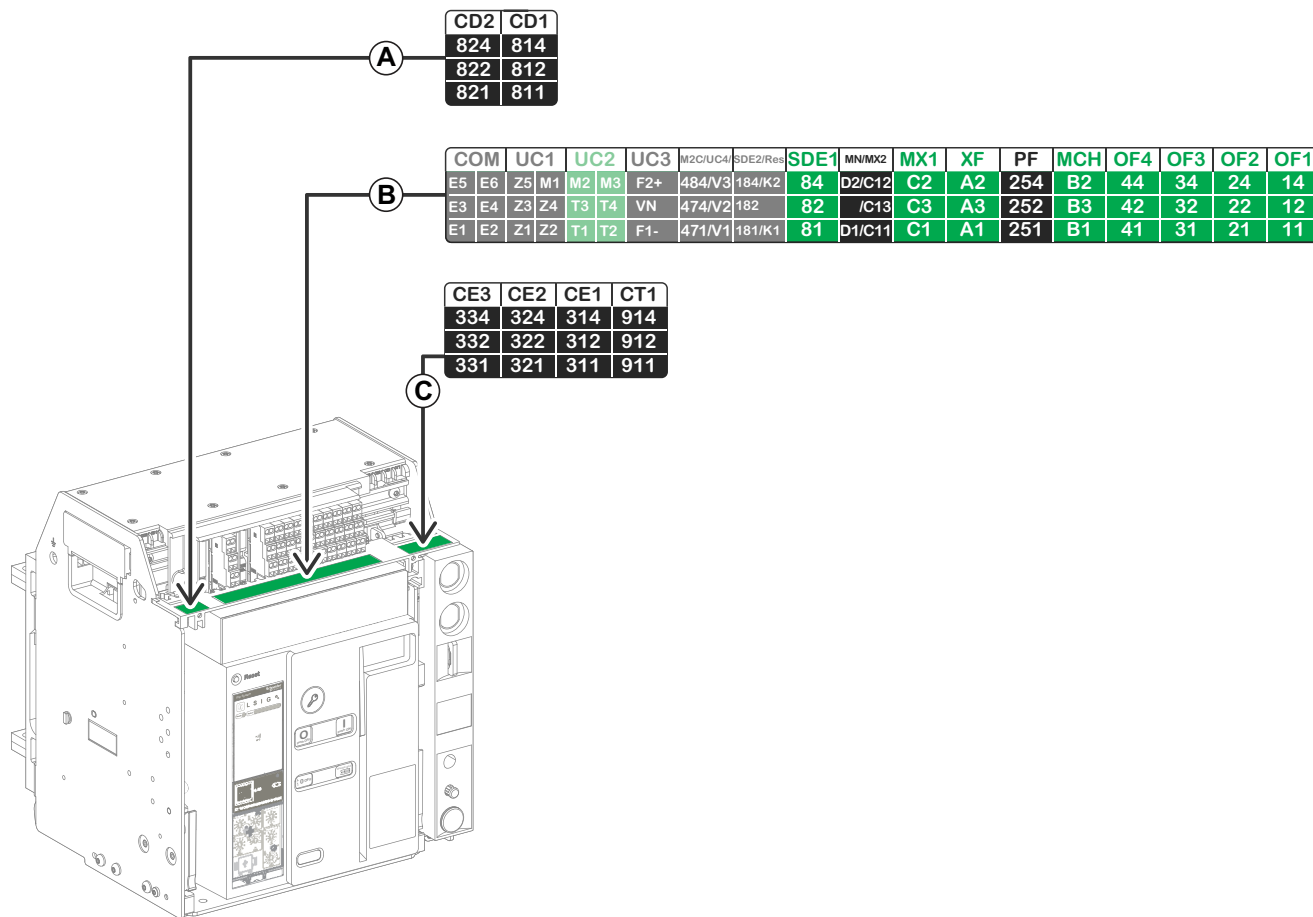

- Terminal block supplied as standard on the chassis
- Terminal block supplied as standard with 3P chassis only
- Terminal block for optional accessories on the chassis
- Terminal block not used on the chassis

Assignment of Chassis Terminal Blocks

⚡ ⚠ DANGER

HAZARD OF ELECTROCUTION FOR VOLTAGES ABOVE 480 VAC

If voltage greater than 480 Vac is connected to a terminal, it is forbidden to connect adjacent terminals to a 24 Vdc SELV (Safety Extra Low Voltage) power supply in order to observe the insulation distances.

Failure to follow these instructions will result in death or serious injury.

The following table describes the assignment and the availability of the terminal blocks for drawout devices:

- Standard terminal blocks are delivered on the chassis, even if the associated accessories are not installed in the devices.
- Optional terminal blocks are delivered on the chassis only if the associated optional accessories are installed in the devices.
- N/A indicates that the terminal blocks and the associated optional accessories are not compatible with the devices.

| Block | Marking | Description | Device |
|-------|----------|---|--|
| A | CD1-CD2 | 2 CD disconnected position contacts | Optional |
| B | COM | Not used | Not used |
| | UC1 | Not used | Not used |
| | UC2 | Neutral external sensor | Standard on 3P devices Optional on 4P devices |
| | UC3 | Not used | Not used |
| | SDE2/RES | Not used | Not used |
| | M2C/UC4 | Not used | Not used |
| | SDE1 | SDE1 fault-trip indication contact | Standard |
| | MN/MX2 | MN undervoltage release or MX2 opening voltage release | Optional |
| | MX1 | MX1 opening voltage release | Standard |
| | XF | XF closing voltage release | Standard |
| | PF | PF ready-to-close contact | Optional |
| | MCH | MCH gear motor | Standard |
| | OF1-OF4 | 4 OF indication contacts | Standard |
| C | CE1-CE3 | 3 CE connected position contact | Optional |
| | CT1 | 1 CT test position contact | |

Device Identification

Identification

The EasyPact MVS1 device can be identified in the following ways:

- Rating plate on the device
- QR code located on the front face of the trip system of the device
- Identification labels on the device and on the chassis

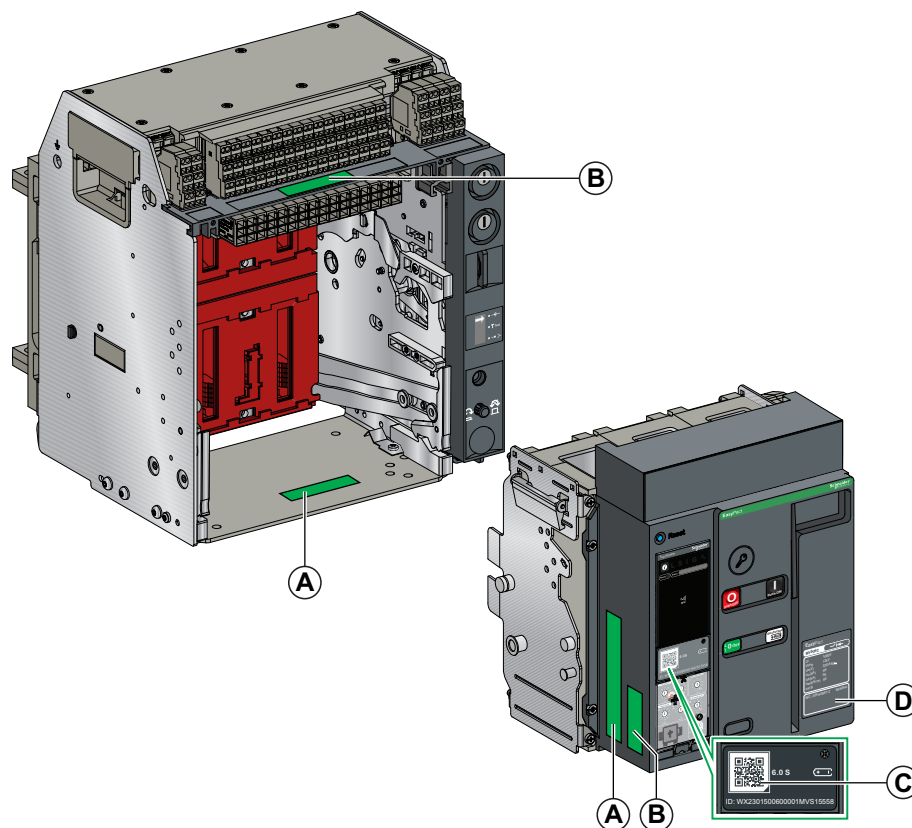

- A** Product identification label
- B** Accessory voltages label
- C** QR code to access product information
- D** Rating plate

Product Identification Label

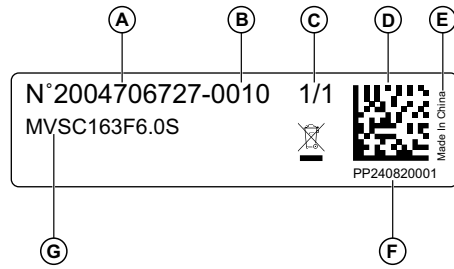

| Legend | Description | Explanation |
|--------|--|--|
| A | Product code | <p>The product code is a line of code representing the complete configuration of a EasyPact device. It is automatically generated for each EasyPact device after completing the configuration by using the Product Selector configuration tool.</p> <p>The product code appears on the invoice and on the delivery documents as well as on the EasyPact device and packaging labels.</p> <p>The product code can be entered in the Product Selector configuration tool, which generates the complete configuration of the EasyPact device.</p> |
| B | Schneider Electric internal identification numbers | – |
| C | Item number/quantity | Item number/quantity is printed on the label. Only the useful character is printed. |
| D | Datamatrix | Datamatrix contains the serial number of the EasyPact device. |
| E | Manufacturing country | Country where the EasyPact device is manufactured. |
| F | Device serial number | <p>The device serial number is coded PYYWWDNNNN, where:</p> <ul style="list-style-type: none"> • PP: Plant code • YY: Year of manufacture • WW: Week of manufacture • D: Day of the week of manufacture (Monday = 1) • NNNN: The production number of the device on the day. Ranges from 0001 to 9999. <p>For example, PP240820001 is the first device manufactured at plant PP on Tuesday, February 20, 2024.</p> |
| G | Description of device | <p>The description of the device, specifies the following characteristics:</p> <ul style="list-style-type: none"> • Range • Performance level • Rating • Number of poles • Trip system type |

Accessory Voltages Label

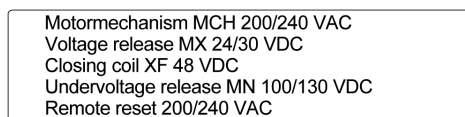

The accessory voltages label gives the voltage of the accessories which are installed in the device and which need to be connected to a power supply.

Rating Plate

The rating plate with the device information is located on the front cover of the device.

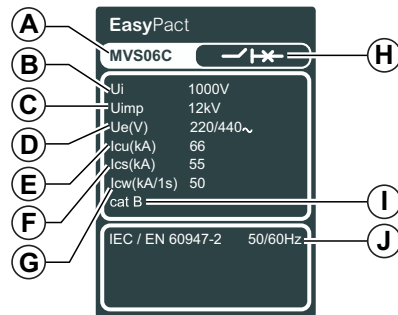

A Device size and rated current x 100 A

B U_i : rated insulation voltage

C U_{imp} : rated impulse withstand voltage

D U_e : rated operational voltage

E I_{cs} : rated service breaking capacity

F Selectivity category as per IEC 60947-2

G Type of device: circuit breaker or switch-disconnector, suitable for insulation

H I_{cu} : rated ultimate short-circuit breaking capacity

I I_{cw} : rated short-circuit breaking capacity

J Frequency

QR Code

When the QR code on the front face of a TS trip system is scanned with a smartphone running a QR code reader and connected to the Internet, the Go2SE Landing Page, page 23 is displayed.

The landing page displays:

- Information about the TS trip system.
- A list of menus.

Go2SE Landing Page

Presentation

When the QR code on the front face of a TS trip system is scanned with a smartphone running a QR code reader and connected to the Internet, the Go2SE landing page is displayed.

The landing page displays:

- Information about the TS trip system.
- A list of menus.

Landing Page Description

The landing page is accessible from Android and iOS smartphones. It displays the same list of menus with slight differences in presentation.

The following example shows the landing page displayed on an Android smartphone:

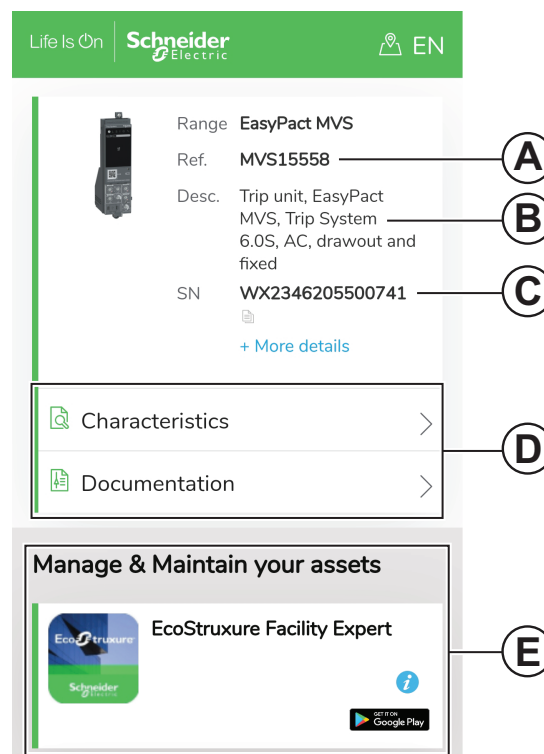

- A. TS trip system commercial reference.
- B. TS trip system description.
- C. TS trip system serial number.
- D. Landing page menus. See the following menu descriptions for details.
- E. Downloadable applications.

Characteristics

Selecting this menu gives access to a product datasheet with detailed information about the TS trip system.

Documentation

Selecting this menu gives access to the technical publications of:

- TS trip systems
- EasyPact MVS devices

mySchneider App

Selecting this application gives access to the Schneider Electric customer care mobile application **mySchneider** app that can be downloaded on Android and iOS smartphones. For smartphone compatibility, check on your application store. The customer care application offers self-service instructions and easy access to expert support and information.

Operating Conditions

Introduction

EasyPact MVS devices are designed and tested for operation in industrial atmospheres. It is recommended that equipment is cooled or heated to the proper operating temperature and kept free of excessive vibration and dust.

Ambient Temperature

EasyPact MVS devices can operate under the following temperature conditions:

- Electrical and mechanical characteristics specified for an ambient temperature of -25 °C to +70 °C.
- Device closing specified down to -35 °C by manual operation with closing pushbutton.

Storage condition is: -40 °C to +85 °C for the device with the trip system.

Extreme Atmospheric Conditions

EasyPact MVS devices have successfully passed tests for extreme atmospheric conditions, defined by the following standards:

| Standard | Title |
|------------------------|---|
| IEC 60068-2-1 | Dry cold, at -40 °C |
| IEC 60068-2-2 | Dry heat, at +85 °C |
| IEC 60068-2-30 | Damp heat (temperature +55 °C, relative humidity 95%) |
| IEC 60068-2-52 level 2 | Salt mist |

Industrial Environments

EasyPact MVS devices can operate in the industrial environments defined by IEC 60947 (pollution degree up to 3).

It is advisable to check that devices are installed in suitably cooled switchboards without excessive dust.

| Conditions | Standard |
|--|---|
| Corrosive industrial atmospheres | Category 3C2 compliant with IEC 60721-3-3 |
| Sea salts 0.8 to 8 mg/m ² day average over the year | Compliant with IEC 60721-2-5 |

Beyond these conditions, EasyPact MVS devices must be installed inside switchboards with an IP rating equal to or greater than IP54.

Vibration

EasyPact MVS devices have successfully passed tests for the following vibration levels, in compliance with IEC 60068-2-6 and IEC 60068-2-27:

- 2 Hz to 13.2 Hz: amplitude +/- 1 mm.
- 13.2 Hz to 100 Hz: constant acceleration of 0.7 g.

Vibration testing to these levels is required by merchant marine inspection organizations (for example, Lloyd's).

EasyPact MVS devices have also been successfully tested according to:

- Annex Q - IEC 60947-1: Special tests – damp heat, salt mist, vibration and shock
- IEC 60947-1 - Category D: Environment subject to temperature, humidity and vibration

Altitude

EasyPact MVS devices are designed and tested to operate at altitudes below 2000 m.

At altitudes above 2000 m, the characteristics of the ambient air (electrical resistance, cooling capacity) lower the product characteristics as follows:

| Characteristics | Altitude | | | |
|--|-----------|--------------|--------------|--------------|
| | 2000 m | 3000 m | 4000 m | 5000 m |
| Impulse withstand voltage U_{imp} (kV) | 12 | 11 | 10 | 8 |
| Rated insulation voltage (U_i) (V) | 1000 | 900 | 780 | 700 |
| Maximum rated operational voltage 50/60 Hz U_e (V) | 690 | 690 | 630 | 560 |
| Rated current (A) at 40 °C | 1 x I_n | 0.99 x I_n | 0.96 x I_n | 0.94 x I_n |

NOTE: Intermediate values can be obtained by interpolation.

Electromagnetic Disturbances

EasyPact MVS devices have protection against:

- Overvoltages caused by devices that generate electromagnetic disturbance.
- Overvoltages caused by atmospheric disturbance or by a distribution-system outage (for example, a lighting system failure).
- Devices emitting radio waves (for example, radio transmitters, walkie-talkies, or radar).
- Electrostatic discharge produced by users.

EasyPact MVS devices have successfully passed the electromagnetic-compatibility tests (EMC) defined by the IEC 60947-2, appendix F international standard.

The devices have passed the above tests and therefore:

- No nuisance tripping occurs.
- Tripping times are respected.

Schneider Electric Green Premium™ Ecolabel

Description

Green Premium is a label that allows you to develop and promote an environmental policy while preserving your business efficiency. This ecolabel is compliant with up-to-date environmental regulations.



Accessing Green Premium

Green Premium data on labeled products can be accessed online through any of the following ways:

- By navigating to the Green Premium page on the Schneider Electric website.
- By navigating to the product page on the mySchneider application on your smartphone.

NOTE: To download and install the mySchneider app, scan the QR code on the front face of any Schneider Electric product and click the mySchneider link to go to your app store.

Checking Products Through the Schneider Electric Website

To check the environmental criteria of a product using a PC or smartphone, follow these steps:

| Step | Action |
|------|---|
| 1 | On the Green Premium page, select Sustainability > For customers > Green Premium products . |
| 2 | Click Check your product and access environmental data . |
| 3 | On the page Check a product , manually enter the commercial reference or product range of the product to search for. NOTE: You can also select the Search a list of part numbers tab to send a file with a list of commercial references of products to search for. |
| 4 | To search for several products simultaneously, click Add product and then fill in the fields. |
| 5 | Click Check product(s) to generate a report of the environmental criteria available for the products with the entered commercial references. |
| 6 | A window named Green Premium Declaration appears. Click on I accept to access the product information. |
| 7 | The Check a product page is displayed with the list of documents for the selected products for each type of environmental data. Each document can be downloaded to your PC. |

Checking Products Through the mySchneider App

To check the environmental criteria of a product using mySchneider app on your smartphone, follow these steps:

| Step | Action |
|------|--|
| 1 | Open the mySchneider app. |
| 2 | In the search field at the top of the Product Catalog page, do one of the following actions: <ul style="list-style-type: none"> • enter the commercial reference of the product to search for • press the QR code icon in the search box  and scan the QR code on the front face of the product to search for. |
| 3 | When the page of the commercial reference searched for opens, scroll down and select Green Premium . |
| 4 | The Green Premium documents attached to the product are listed on the Green Premium page. Select the required document to refer to or download it. |

Environmental Criteria

The Green Premium ecolabel provides documentation on the environmental impact of the products:

- RoHS: Restriction of Hazardous Substances (RoHS) directive
 - For European Union
 - For China
- REACH: European Union Registration, Evaluation, Authorization, and Restriction of Chemicals regulation.
- Product Environmental Profile (PEP)
- End of Life Instructions (EoLI).

RoHS

Schneider Electric products are subject to RoHS requirements at a worldwide level, even for products that are not required to comply with the terms of the regulation. Compliance certificates are available for products that fulfill:

- RoHS criteria defined by the European Union.
- RoHS criteria defined by China.

REACH

Schneider Electric applies the strict REACH regulation on its products at a worldwide level, and discloses extensive information concerning the presence of Substances of Very High Concern (SVHC) in all of these products.

Product Environmental Profile (PEP)

Schneider Electric publishes complete set of environmental data, including carbon footprint and energy consumption data for each life cycle phase of its products, in compliance with the ISO 14025 PEP ecopassport program. Product environmental profile is especially useful for monitoring, controlling, saving energy, and/or reducing carbon emissions.

End of Life Instructions (EoLI)

The end of life instructions are in compliance with the Waste Electrical and Electronic Equipment (WEEE) directive and provide:

- Recyclability rates for Schneider Electric products.
- Guidance to mitigate personnel hazards during the dismantling of products and before recycling operations.
- Part identification for recycling or for selective treatment, to mitigate environmental hazards/incompatibility with standard recycling processes.

EasyPact MVS1 Normal Operation

What's in This Part

| | |
|-------------------------------------|----|
| Device Operating Actions..... | 31 |
| Drawout Device Racking Actions..... | 41 |
| Device Locking Actions..... | 54 |
| Device Interlocking Actions..... | 71 |

Device Operating Actions

What's in This Chapter

| | |
|----------------------------|----|
| Operating the Device..... | 32 |
| Opening the Device..... | 36 |
| Closing the Device | 37 |
| Resetting the Device | 38 |
| Operating Accessories..... | 39 |

Operating the Device

Device Status

The indicators on the front of the device show the following information:

- Reset button:
 - In: the device is closed or open voluntarily (not tripped)
 - Out: the device has tripped
- Position indicator of main contacts: ON or OFF.
- Closing spring and ready-to-close indicator. The state can be one of the following:
 - Discharged (no energy to close the device)
 - Charged not ready-to-close
 - Charged ready-to-close

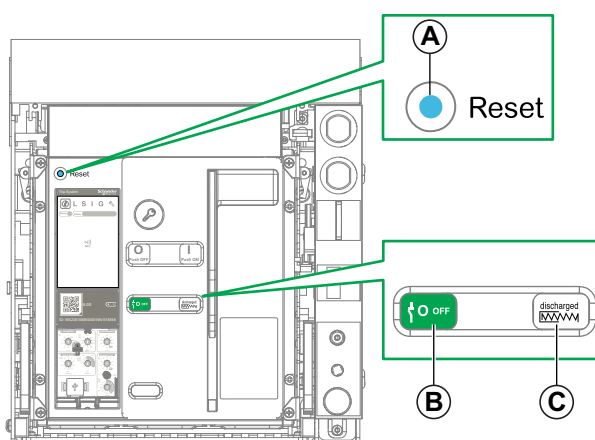

A Reset button

B Position indicator of main contacts



C Closing spring and ready-to-close indicator

The combination of both indicators gives the device status:

| Position indicator of main contacts | Closing spring and ready-to-close indicator | Device status description |
|-------------------------------------|---|---|
| | | Device is off (main contacts are open) and closing spring is discharged. |
| | | Device is off (main contacts are open) and closing spring is charged. The device is not ready-to-close because at least one of the following conditions is true: <ul style="list-style-type: none"> • The device has tripped and must be reset. • The MX opening voltage release is energized. • The MN undervoltage release is not energized. • The device is mechanically locked in the open position by using padlock or keylock or by using an interlocking system. |
| | | Device is off (main contacts are open) and closing spring is charged. The device is ready-to-close. |
| | | Device is on (main contacts are closed) and closing spring is discharged. |
| | | Device is on (main contacts are closed) and closing spring is charged. The device is not ready-to-close because it is already closed. |

Device Indication Contacts

The position of the device main contacts is indicated by OF indication contacts.

| Name | Contact number | Position of indicators and contacts | | |
|-------------------------------------|----------------|--|---|---|
| Device status | – | ON | OFF | Tripped (by TS trip system) |
| Position indicator of main contacts | – |  |  |  |
| Main contact position | – | Closed | Open | Open |
| Reset button position | – | IN | IN | OUT |
| OF indication contact position | 1–2 | Open | Closed | Closed |
| | 1–4 | Closed | Open | Open |
| SDE indication contact position | 1–2 | Closed | Closed | Open |
| | 1–4 | Open | Open | Closed |

Anti-Pumping Function

EasyPact MVS devices provide a mechanical anti-pumping function. In the event of simultaneous maintained opening and closing orders, the standard mechanism blocks the main contacts in the open position. After a trip due to an electrical fault or intentional opening using the manual or electrical controls, the closing order must first be discontinued, then reactivated to close the device. This prevents a cycle of closing and opening.

When remote operation features are used, allow at least four seconds for the MCH gear motor to charge the device closing spring completely before the XF closing voltage release is actuated.

To prevent the device from closing prematurely, the PF ready-to-close contact can be series connected with the XF closing voltage release.

Charging the Closing Spring

The closing spring must be charged with sufficient energy to close the EasyPact MVS:

- Manual charge: Charge the mechanism by pulling the spring charging handle down seven times.

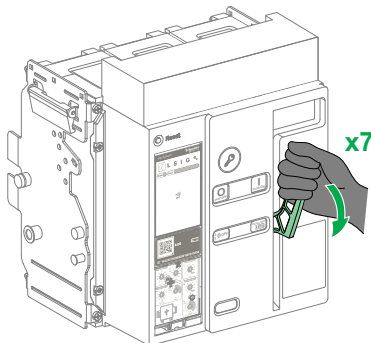

- Automatic charge: If the optional MCH gear motor is installed, the spring is automatically charged after closing.

Manual Operation Cycle with the Spring Charging Handle

The following image shows an Open/Close/Open (OCO) cycle for manually charged devices without MCH gear motor:

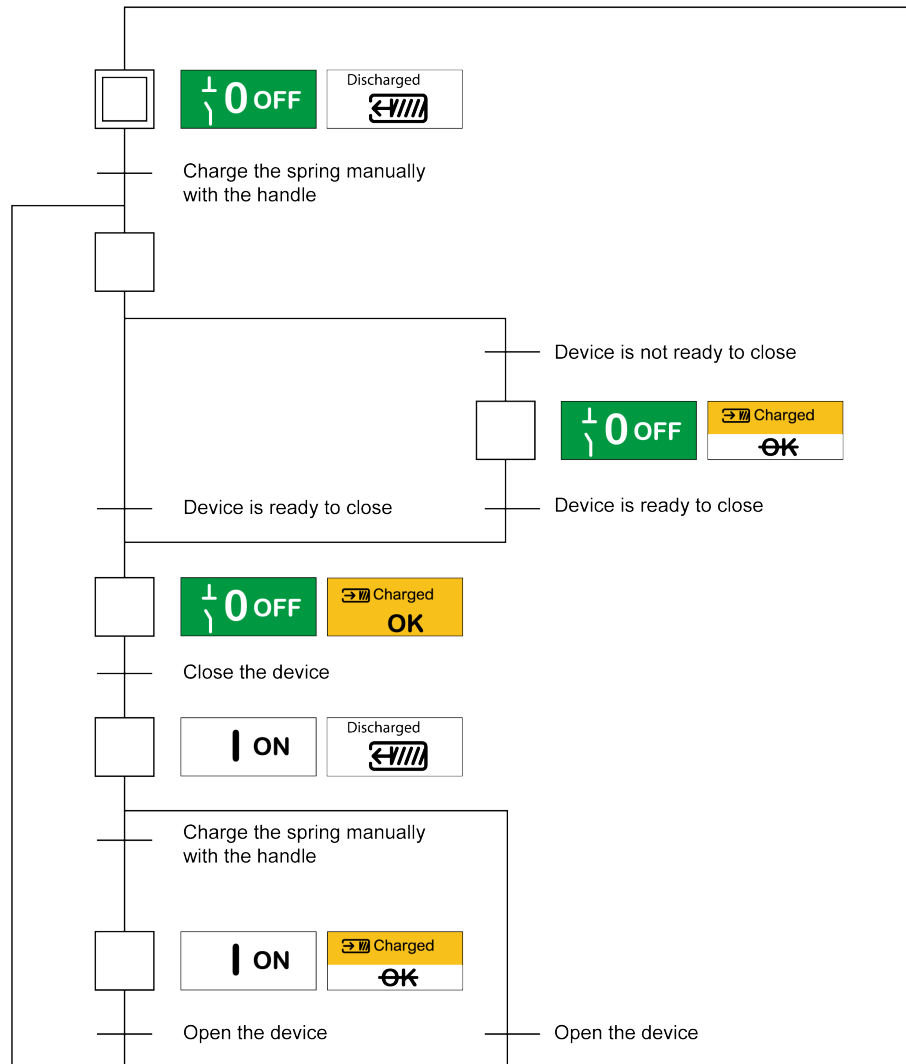

Electrical Operation Cycle with an MCH Gear Motor

The following image shows an Open/Close/Open (OCO) cycle for electrically charged devices using an MCH gear motor:

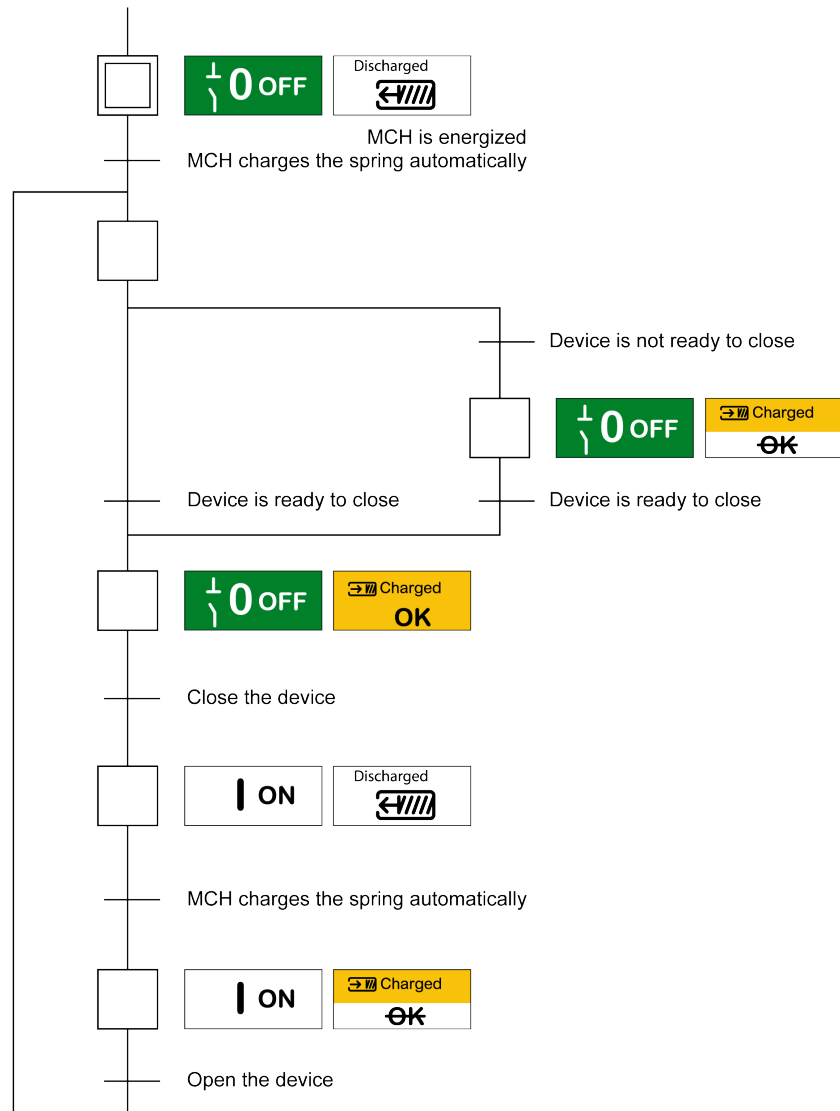

Opening the Device

Opening Conditions

To open the device, the device must be closed (I).

NOTE: An opening order always takes priority over a closing order.

Opening the Device

The following tables present the different ways to open the device.

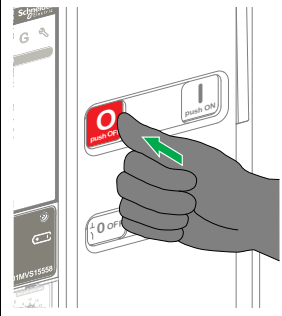
| Opening type | Accessories | Opening action |
|------------------------|---|---|
| Mechanical | – | <p>Press the opening pushbutton on the front of the device.</p> <p>This opening action is possible at any time.</p>  |
| Automatic | MN undervoltage release, with or without MN delay unit | The MN undervoltage release opens the device automatically in the case of voltage drop. |
| By external pushbutton | <ul style="list-style-type: none"> • External pushbutton wired by customer • One of the following accessories: <ul style="list-style-type: none"> ◦ MX standard opening voltage release ◦ MN undervoltage release, with or without MN delay unit | <p>Press the external pushbutton which is connected to the MX opening voltage release or to the MN undervoltage release via the customer terminal block.</p> <p>When the MN undervoltage release is connected to the MN delay unit, the device opens with the corresponding time delay.</p> |

Closing the Device

Closing Conditions

To close the device, the following conditions must be met:

- Device is open (O).
- Closing spring is charged.
- The device is ready to close, **OK** is displayed.

NOTE: An opening order always takes priority over a closing order. The device cannot be closed while an opening order is being received. If **OK** is crossed-out on the ready-to-close indicator, an order to open is being received (either electrically or mechanically) and must be ended before **OK** can be displayed.

⚡ ⚠ DANGER

HAZARD OF ELECTRIC SHOCK, EXPLOSION, OR ARC FLASH

Do not re-close the device on an electrical fault. First inspect and, if necessary, repair the downstream equipment.

Failure to follow these instructions will result in death or serious injury.

Closing the Device

The following tables present the different ways to close the device.

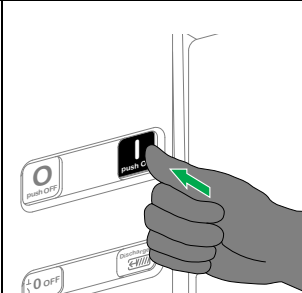
| Closing type | Accessories | Closing action |
|---------------------|--|--|
| Mechanical | – | <p>Press the closing pushbutton on the front of the device.</p> <p>The closing action is possible when the closing conditions are met.</p>  |
| External pushbutton | <ul style="list-style-type: none"> • External pushbutton wired by customer • XF standard closing voltage release • MCH gear motor | <p>Press the external pushbutton, which is connected to the XF closing voltage release through the customer terminal block.</p> |

Resetting the Device

Resetting Conditions

After a trip, the device must be reset before closing it.

Resetting the Device

The device can be reset in different ways, according to the device configuration and its accessories:

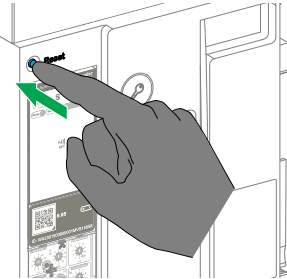
| Type of resetting | Accessories | Resetting action | |
|--|-------------|--|---|
| Mechanical with the blue fault-trip reset button | – | Push in the blue fault-trip reset button on the front of the device. This resetting action is always possible. Pushing in the blue fault-trip reset button resets the SDE fault-trip indication contact, and allows the device to be closed. |  |

Operating Accessories

For information on operating accessory installation, consult the instruction sheet on the Schneider Electric website: MVS21736.

XF, MX, and MN Voltage Releases

XF, MX, and MN voltage releases are optional accessories mounted inside the device.

The standard voltage releases are designed to receive either pulse-type or maintained voltage operating orders.

XF Closing Voltage Release

The XF closing voltage release closes the device instantaneously when powered if the spring mechanism is charged. The minimum duration of the pulse operating order must be 200 ms.

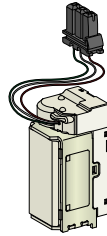

MX Opening Voltage Release

The MX opening voltage release opens the device instantaneously when powered. The minimum duration of the pulse operating order must be 200 ms. The MX standard opening voltage release locks the device in OFF position if the command is maintained.

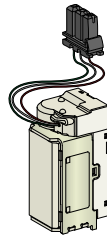

MN Undervoltage Release

The MN undervoltage release instantaneously opens the device when its supply voltage drops to a value between 35% and 70% of its rated voltage. If there is no supply to the release, it is impossible to close the device, either manually or electrically. Any attempt to close the device has no effect on the main contacts. Device closing is enabled again when the supply voltage of the release returns to 85% of its rated value.

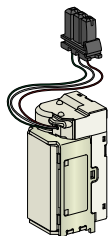

PF Ready-to-close Contact

This is an optional accessory that is mounted inside the device.

The PF ready-to-close contact delivers remotely, the indication delivered locally by the ready-to-close indicator.

It consists of a changeover contact indicating remotely that the device is ready to close, that is:

- The device is in the open position.
- The spring mechanism is charged.
- There is no maintained opening order.

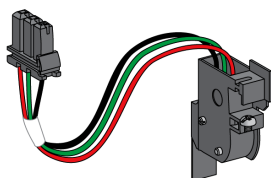

MCH Gear Motor

This is an optional accessory that is mounted inside the device.

The MCH gear motor automatically charges the spring mechanism when the device is closed, allowing instantaneous closing of the device following opening.

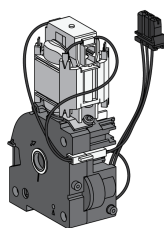

CDM Mechanical Operation Counter

This is an optional accessory that is mounted inside the device.

The CDM mechanical operation counter counts the number of operating cycles and is visible on the front panel. It is compatible with manual and electrical control functions.

This option is compulsory for all source-changeover systems.

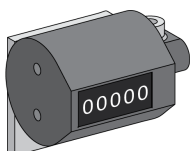

Drawout Device Racking Actions

What's in This Chapter

| | |
|---|----|
| Drawout EasyPact MVS1 Device Status | 42 |
| Disconnecting the Drawout Device | 45 |
| Connecting the Drawout Device | 47 |
| Removing the Drawout Device | 49 |
| Installing the Drawout Device in the Chassis..... | 52 |

Drawout EasyPact MVS1 Device Status

Drawout Device Handling Conditions

Connection or disconnection of the drawout device requires insertion of the racking handle. When interlocks, padlocks, or an open door lock are in place, the racking handle cannot be inserted.

⚡ ⚠ DANGER

HAZARD OF ELECTRIC SHOCK, EXPLOSION OR ARC FLASH

- Apply appropriate personal protective equipment (PPE) and follow safe electrical work practices. See NFPA 70E or CSA Z462 or local equivalent.
- This equipment must only be installed and serviced by qualified electrical personnel.

Failure to follow these instructions will result in death or serious injury.

Drawout Device Positions

The indicator located on the front of the chassis locally signals the position of the device in the chassis.

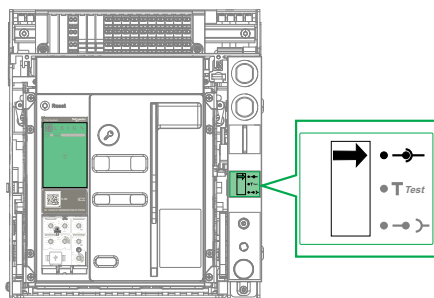

| Device position | Position indicator and position contact state | Connector position | Device status |
|-----------------|---|---|--|
| Connected | | <ul style="list-style-type: none"> • Disconnecting contact clusters: engaged • Control: engaged | <ul style="list-style-type: none"> • Can be operated. • Ready for service. |
| Test | | | <ul style="list-style-type: none"> • Can be operated. • Can have operation and control systems tested. |

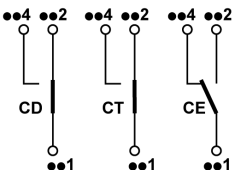
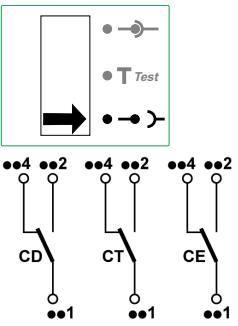
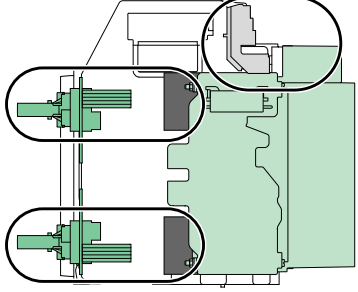
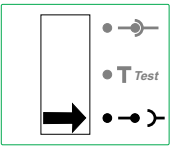
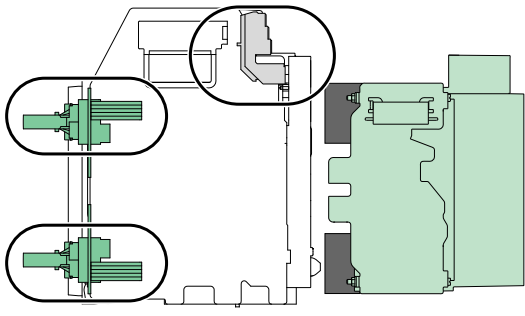
| Device position | Position indicator and position contact state | Connector position | Device status |
|-----------------|--|---|--|
| |  | <ul style="list-style-type: none"> • Disconnecting contact clusters: disengaged - the minimum distance between the device racking terminals and the chassis clusters is reached. • Control: engaged | |
| Disconnected |  |  <ul style="list-style-type: none"> • Disconnecting contact clusters: disengaged • Control: disengaged | <ul style="list-style-type: none"> • Can be operated. • Can be removed from chassis. |
| Withdrawn |  |  <ul style="list-style-type: none"> • Disconnecting contact clusters: disengaged • Control: disengaged | Removed from chassis. |

Drawout Device Position Contacts

The position of the device in the chassis can be indicated remotely by the following optional position contacts:

- 2 CD disconnected position contacts
- 3 CE connected position contacts
- 1 CT test position contact

The state of the position contacts changes according to the device position during racking-in and racking-out operations, as shown in the diagram below.

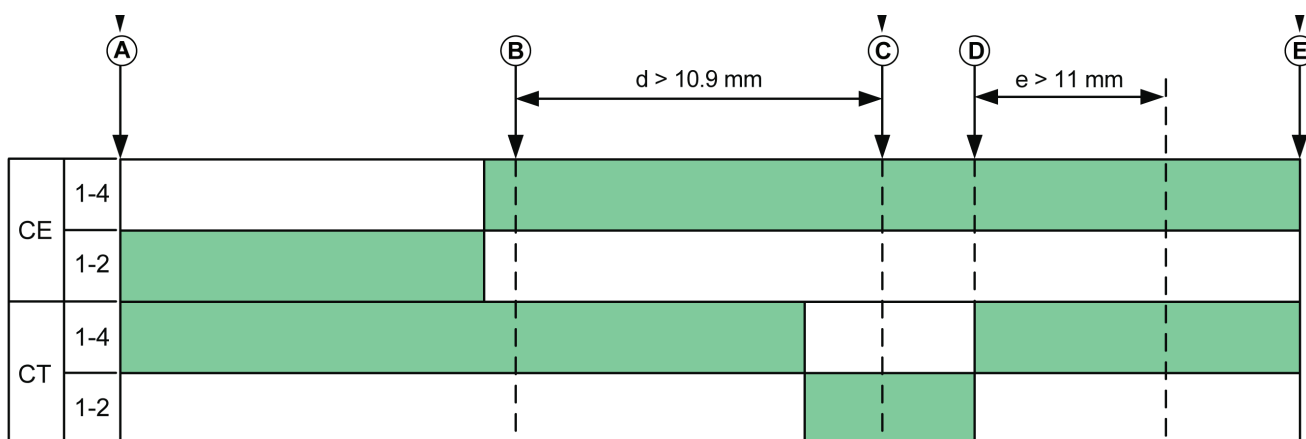
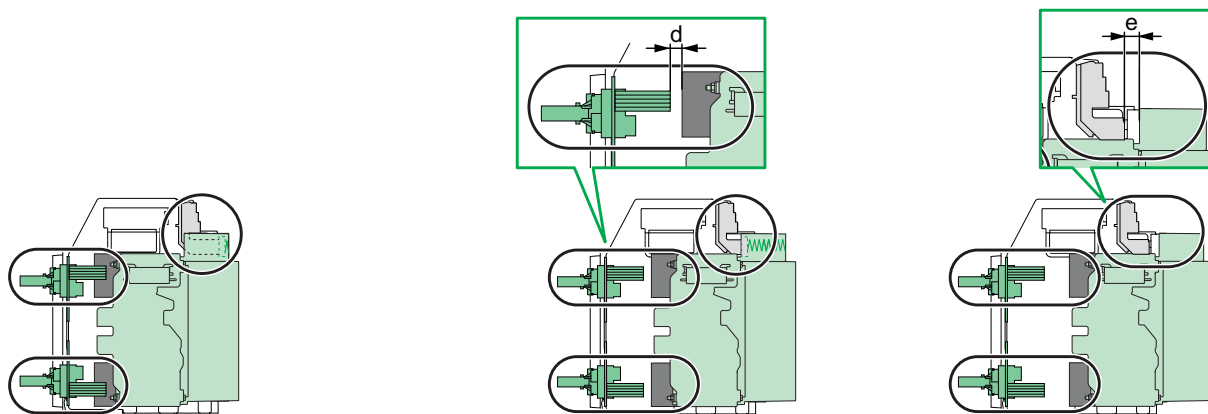

- A** Device in connected position
- B** Separation of the main circuits
- C** Device in test position
- D** Separation of auxiliary circuits
- E** Device in disconnected position

Position contact is open.

Position contact is closed.

Disconnecting the Drawout Device

Drawout Device Handling Conditions

Connection or disconnection of the drawout device requires insertion of the racking handle. When chassis locking by keylocks, padlocks, or an open door lock are in place, the racking handle cannot be inserted.

⚠️ ⚠️ DANGER

HAZARD OF ELECTRIC SHOCK, EXPLOSION OR ARC FLASH

- Apply appropriate personal protective equipment (PPE) and follow safe electrical work practices. See NFPA 70E or CSA Z462 or local equivalent.
- This equipment must only be installed and serviced by qualified electrical personnel.

Failure to follow these instructions will result in death or serious injury.

NOTICE

HAZARD OF EQUIPMENT DAMAGE

- Use the provided racking handle to rack the device into or out of chassis.
- Do not use power tools for racking.
- Do not turn the handle after position release button has popped out.

Failure to follow these instructions can result in equipment damage.

Racking-out the Device from Connected to Test Position

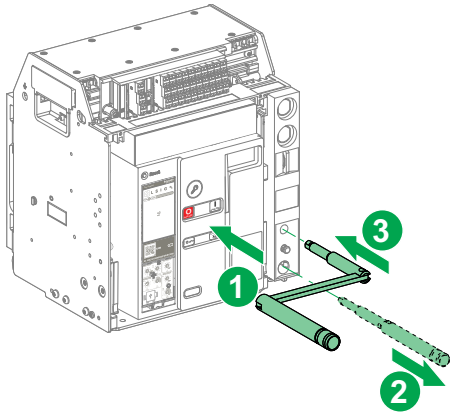
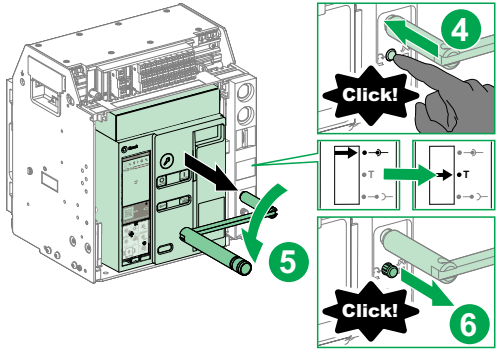
| Step | Action | |
|------|--|--|
| 1 | Press the opening pushbutton to open the device. |  |
| 2 | Remove the racking handle from its storage space. | |
| 3 | Insert the racking handle into the racking handle socket. | |
| 4 | Push in the position release button. |  |
| 5 | Turn the racking handle counterclockwise. Result: The device moves forward in the chassis. | |
| 6 | When the test position is reached, the position release button pops out and the mechanism blocks the racking handle. Result: The device is in the test position. | |

Racking-out the Device from Test to Disconnected Position

| Step | Action | |
|------|--|--|
| 1 | Push in the position release button. | |
| 2 | Turn the racking handle counterclockwise. Result: The device moves forward in the chassis. | |
| 3 | When the disconnected position is reached, the position release button pops out and the mechanism blocks the racking handle. Result: The device is in the disconnected position. | |
| 4 | Remove the racking handle from the racking socket. | |
| 5 | Put the racking handle back into its storage space. | |

Connecting the Drawout Device

Drawout Device Handling Conditions

Connection or disconnection of the drawout device requires insertion of the racking handle. When chassis locking by keylocks, padlocks, or an open door lock are in place, the racking handle cannot be inserted.

⚠️ ⚠️ DANGER

HAZARD OF ELECTRIC SHOCK, EXPLOSION OR ARC FLASH

- Apply appropriate personal protective equipment (PPE) and follow safe electrical work practices. See NFPA 70E or CSA Z462 or local equivalent.
- This equipment must only be installed and serviced by qualified electrical personnel.

Failure to follow these instructions will result in death or serious injury.

NOTICE

HAZARD OF EQUIPMENT DAMAGE

- Use the provided racking handle to rack the device into or out of chassis.
- Do not use power tools for racking.
- Do not turn the handle after position release button has popped out.

Failure to follow these instructions can result in equipment damage.

Racking-in the Device from Disconnected to Test Position

| Step | Action | |
|------|--|--|
| 1 | Remove the racking handle from its storage space. | |
| 2 | Insert the racking handle into the racking handle socket. | |
| 3 | Push the position release button. | |
| 4 | Turn the racking handle clockwise. Result: The device moves back in the chassis. | |
| 5 | When the test position is reached, the position release button pops out and the mechanism blocks the racking handle. Result: The device is in the test position. | |

Racking-in the Device from Test to Connected Position

| Step | Action | | |
|------|--|--|--|
| 1 | Push the position release button. | | |
| 2 | Turn the racking handle clockwise. Result: The device moves back in the chassis. | | |
| 3 | When the connected position is reached, the position release button pops out and the mechanism blocks the racking handle. Result: The device is in the connected position. | | |
| 4 | Remove the racking handle from the racking socket. | | |
| 5 | Put the racking handle back into its storage space. | | |

Removing the Drawout Device

Device Removal

| | |
|---|--|
| NOTICE | |
| HAZARD OF EQUIPMENT DAMAGE | |
| The chassis must be securely fastened when installing or removing the device. | |
| Failure to follow these instructions can result in equipment damage. | |

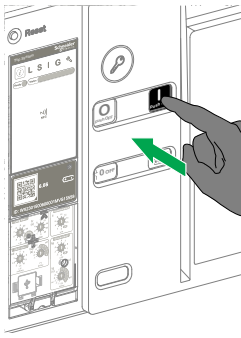
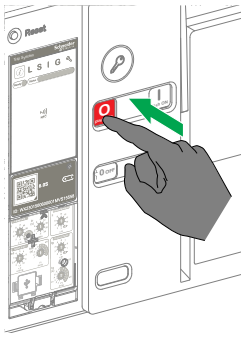
| Step | Action |
|------|---|
| 1 | <p>After disconnected position, page 45, discharge the closing spring by pressing the closing pushbutton. If the closing spring is charged, the device closes.</p>  |
| 2 | <p>Press the opening pushbutton to open the device.</p>  |

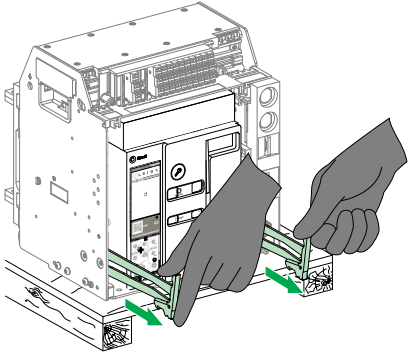
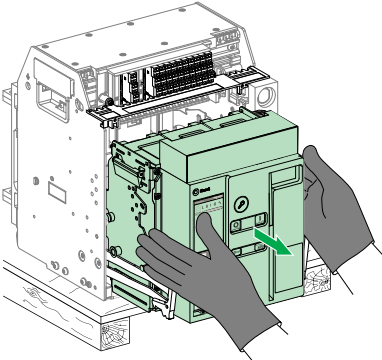
| Step | Action | |
|------|--|--|
| 3 | Pull out the rails to the maximum by pulling on the drawout grips. The moving part of the drawout device stays in disconnected position in the chassis. |  |
| 4 | Pull out the moving part of the drawout device to the maximum, by rolling it along the rails. Result: The device is supported on the rails, clear of the chassis and ready to be lifted. |  |

Lifting the Device

Both the device and chassis have a carrying grip for lifting. To lift the device, use an overhead lifting device attached to the carrying grip, following the directions given in this section.

⚠ DANGER

HAZARD OF DEVICE FALLING

- Be sure that lifting equipment has lifting capacity for the device being lifted.
- Follow manufacturer's instructions for use of lifting equipment.
- Wear hard hat, safety shoes, and heavy gloves.

Failure to follow these instructions will result in death or serious injury.

Lift the device from the chassis rails by using the carrying grip located on the sides of the device.

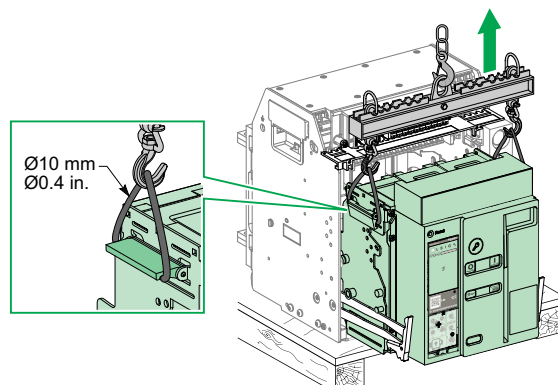

Device Weights

The following table shows the weights of the different devices available.

| Number of poles | Device | MVS1 |
|-----------------|-----------------------|-------|
| 3P | Moving part (Drawout) | 15 kg |
| | Chassis | 16 kg |
| | Fixed device | 15 kg |
| 4P | Moving part (Drawout) | 19 kg |
| | Chassis | 21 kg |
| | Fixed device | 19 kg |

Installing the Drawout Device in the Chassis

Drawout Device Handling Conditions

Connection or disconnection of the drawout device requires insertion of the racking handle. When chassis locking by keylocks, padlocks, or an open door lock is in place, the racking handle cannot be inserted.

⚡⚠ DANGER

HAZARD OF ELECTRIC SHOCK, EXPLOSION OR ARC FLASH

- Apply appropriate personal protective equipment (PPE) and follow safe electrical work practices. See NFPA 70E or CSA Z462 or local equivalent.
- This equipment must only be installed and serviced by qualified electrical personnel.

Failure to follow these instructions will result in death or serious injury.

NOTICE

HAZARD OF EQUIPMENT DAMAGE

- Use the provided racking handle to rack the device into or out of chassis.
- Do not use power tools for racking.
- Do not turn the handle after position release button has popped out.

Failure to follow these instructions can result in equipment damage.

Installing the Device

⚠ DANGER

HAZARD OF DEVICE FALLING

- Be sure that lifting equipment has lifting capacity for the device being lifted.
- Follow manufacturer’s instructions for use of lifting equipment.
- Wear hard hat, safety shoes, and heavy gloves.

Failure to follow these instructions will result in death or serious injury.

NOTICE

HAZARD OF EQUIPMENT DAMAGE

- Chassis must be securely fastened when installing or removing the device.
- Before mounting the device, make sure that it matches the chassis.

Failure to follow these instructions can result in equipment damage.

| Step | Action |
|------|--|
| 1 | If the chassis is not installed yet in a switchboard or panelboard, securely fasten the chassis on a pallet. |
| 2 | Remove the racking handle from its storage space. |
| 3 | Check that the chassis indicator is in the disconnected position: |

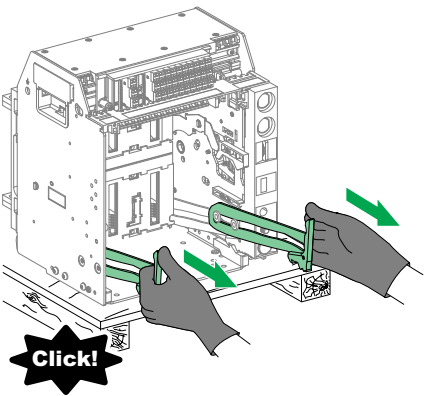
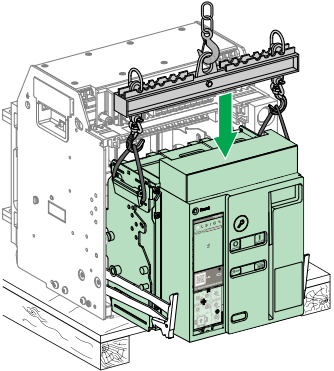
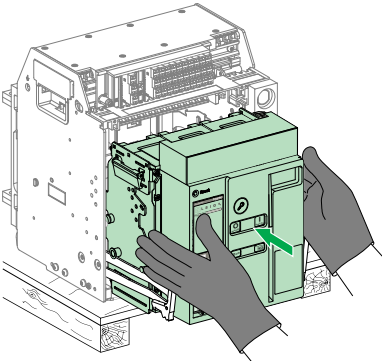
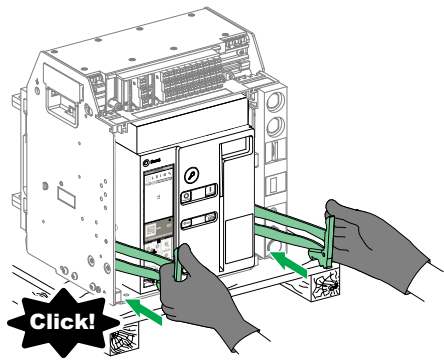
| Step | Action | |
|------|---|--|
| | <p>If the chassis indicator is not in the disconnected position, follow the steps on disconnecting the drawout device, page 45.</p> | |
| 4 | <p>Pull out the drawout grips until the extension rails are fully extended.</p> |  |
| 5 | <p>Install the device on the extension rails by using appropriate lifting equipment.</p> <p>Check that the four wheels on the sides of device are resting on the rails.</p> |  |
| 6 | <p>Detach the lifting equipment.</p> | |
| 7 | <p>Check that the device is in the open position.</p> | |
| 8 | <p>Using both hands, push in the device to the maximum in the chassis. Take care not to push the trip system. The rails stay extended.</p> |  |
| 9 | <p>When the device is fully inserted into the chassis, lift and push in the rails to the maximum.</p> |  |

Device Locking Actions

What's in This Chapter

| | |
|---|----|
| Locking the Pushbuttons | 55 |
| Locking the Device in Open Position with Keylocks | 57 |
| Chassis Locking in Disconnected Position | 60 |
| Chassis Locking in Any Position | 65 |
| Locking the Safety Shutters | 70 |

About Locking Actions

A locking action is a manual locking operation made by the user. A number of optional locking accessories are available for the EasyPact MVS1 device and chassis.

Locking the Pushbuttons

Description

The pushbutton locking cover is an optional accessory for the EasyPact MVS1 device that forbids access to the closing and opening pushbuttons:

- Together or separately.
- By using a padlock (shackle diameter 5–8 mm).
- By using a lead seal.
- By using screws.

IMPORTANT: The use of the pushbutton locking cover is mandatory to padlock the closing pushbutton when a EasyPact MVS1 device is used as a transfer switch.

For more information, refer to *Mechanical Interlocking for Transfer Switches*, page 77.

VBP Pushbutton Locking Accessory

The pushbutton locking accessory is an optional transparent cover, mounted on the front cover of the device, which covers the closing and opening pushbuttons.

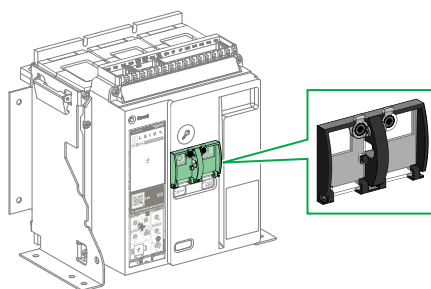

For information on the accessory installation, consult the instruction sheet on the Schneider Electric website: [MVS21736](https://www.schneider-electric.com/asset/document/MVS21736).

Locking the Pushbuttons

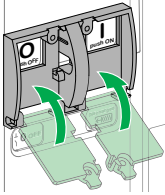
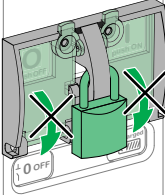
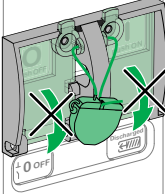
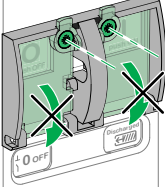
| Step | Action | |
|------|--|--|
| 1 | Close the transparent covers of the locking accessory. NOTE: One or both transparent covers of the locking accessory can be closed and locked. |  |
| 2 | Lock the transparent covers in place by using a padlock, lead seal, or screws. | <p data-bbox="1219 501 1299 524">Padlock</p>  <p data-bbox="1219 770 1315 792">Lead seal</p>  <p data-bbox="1219 1039 1299 1061">Screws</p>  |

Locking the Device in Open Position with Keylocks

Description

Optional keylocks can be used:

- To lock one EasyPact MVS1 device in the open position. When locked the device cannot be closed either locally with the closing pushbutton or remotely.
- To interlock several EasyPact MVS1 device locked with the same key.

To use keylocks to lock the device in the open position, an optional OFF-position locking accessory is necessary.

VSPO OFF-Position Locking Accessory

The OFF-position locking accessory is an optional accessory that is mounted on the front of the device.

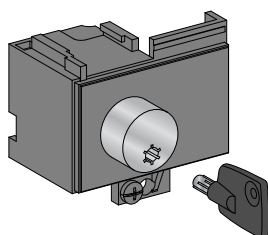

The OFF-position keylocking accessory can be fitted with one Profalux keylock.

For information on the accessory installation, consult the instruction sheet on the Schneider Electric website: [MVS21736](https://www.schneider-electric.com/Products/Accessories/VSPO-Off-Position-Locking-Accessory).

Locking the Device in the Open Position

For devices equipped with two keylocks, locking with one key is sufficient to lock the device in the open position.

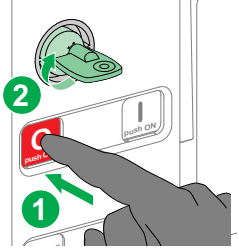
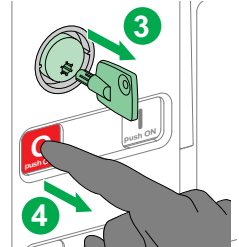
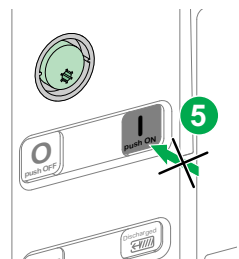
| Step | Action | |
|------|---|--|
| 1 | Press and hold the opening pushbutton. |  |
| 2 | With the opening pushbutton pressed, turn the key clockwise to lock the device. | |
| 3 | Remove the key. |  |
| 4 | Release the opening pushbutton. | |
| 5 | Check that the device is locked in the open position and cannot be closed either locally with the closing pushbutton or remotely. |  |

Unlocking the Device

For devices equipped with two keylocks, both keys must be inserted in the keylocks to unlock the device.

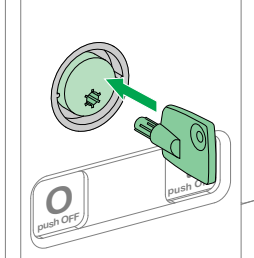
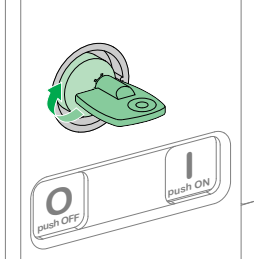
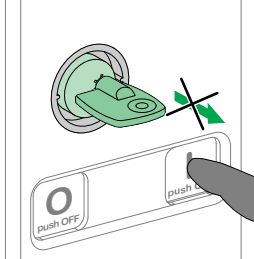
| Step | Action | |
|------|---|--|
| 1 | Put the key in the keylock. |  |
| 2 | Turn the key clockwise to unlock the device. |  |
| 3 | Press the closing pushbutton to close the device. NOTE: The key remains captive in the keylock. |  |

Chassis Locking in Disconnected Position

Description

The chassis can be locked in the disconnected position. When the chassis is locked in the disconnected position, the racking handle cannot be inserted.

The chassis can be locked in the disconnected position:

- By up to three padlocks with shackle diameter 5–8 mm.
- By optional keylocks.

Keylocks can be used in addition to padlocks.

Chassis locking by padlock is always possible and does not require any accessory.

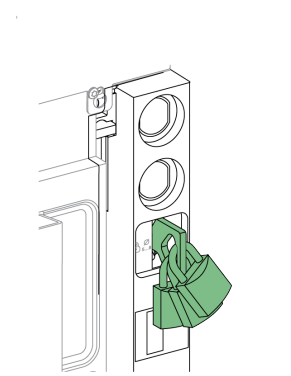

VSPD Chassis Locking by Keylock Accessory

The chassis locking by keylock accessory can be fitted with one keylock.

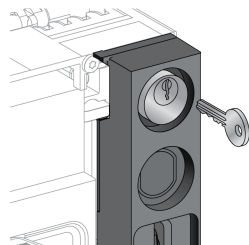

The following types of keylocks can be fitted:

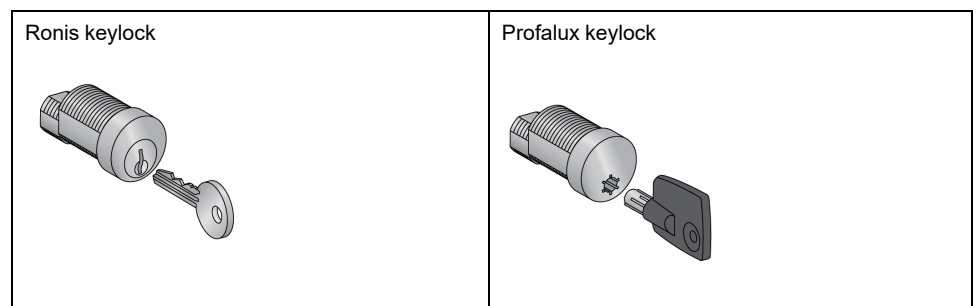

For information on the accessory installation, consult the instruction sheet on the Schneider Electric website: [MVS21737](#).

Chassis Locking with Padlocks

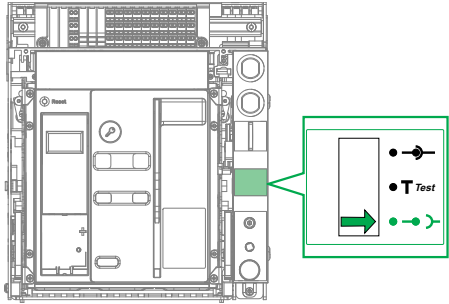
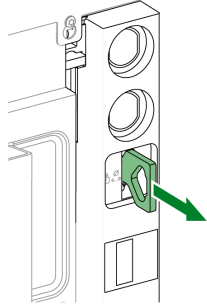
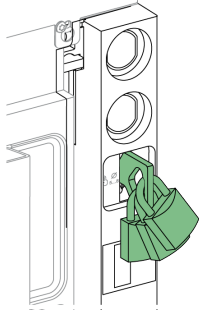
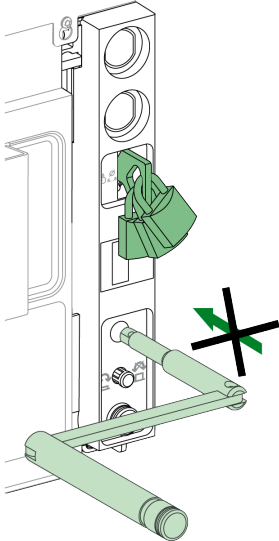
| Step | Action | |
|------|--|--|
| 1 | Check that the chassis indicator is in the disconnected position. |  <p>The diagram shows a top-down view of the circuit breaker chassis. A callout box on the right highlights a specific indicator. Inside the callout, there are three symbols: a circle with a horizontal line through it, a circle with a vertical line through it labeled 'Test', and a circle with a diagonal line through it. A green arrow points to the diagonal line symbol, indicating the disconnected position.</p> |
| 2 | Pull out the padlocking tab. |  <p>The diagram shows a close-up of the padlocking tab on the side of the circuit breaker. A green arrow points to the tab, indicating it should be pulled out.</p> |
| 3 | Insert the padlocks in the tab and close the padlocks. |  <p>The diagram shows the padlocking tab with two padlocks inserted into it. The padlocks are shown in a closed position.</p> |
| 4 | Check that the racking handle cannot be inserted into the racking handle socket. |  <p>The diagram shows the racking handle being inserted into the racking handle socket. A large black 'X' is drawn over the handle, indicating that it should not be inserted.</p> |

Chassis Unlocking with Padlocks

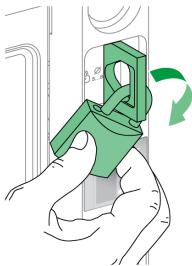
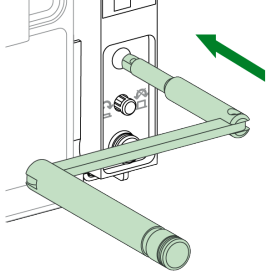
| Step | Action | |
|------|---|---|
| 1 | Remove the padlocks. The tab retracts. |  |
| 2 | Check that the racking handle can be inserted into the racking handle socket. |  |

Chassis Locking with Keylocks

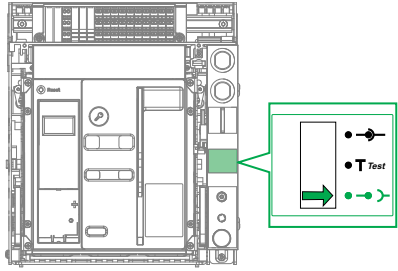
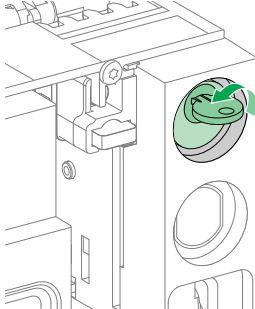
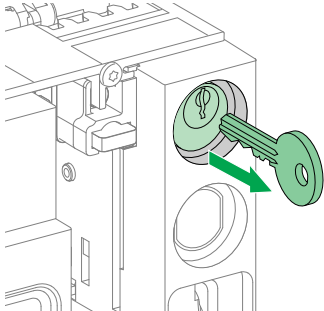
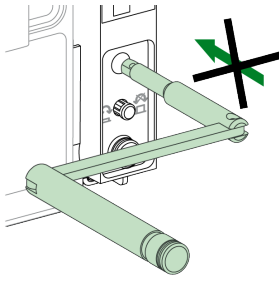
| Step | Action | |
|------|--|---|
| 1 | Check that the chassis indicator is in the disconnected position. |  |
| 2 | Turn the key counterclockwise to lock the chassis. |  |
| 3 | Remove the key. |  |
| 4 | Check that the racking handle cannot be inserted into the racking handle socket. |  |

Chassis Unlocking with Keylocks

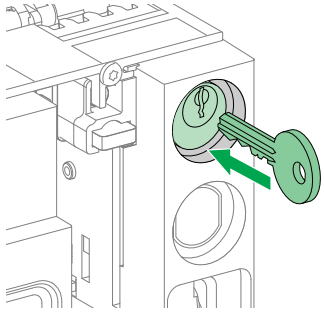
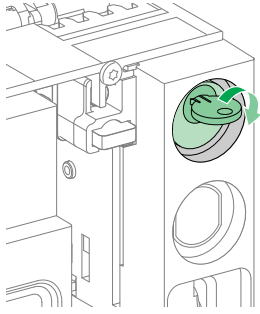
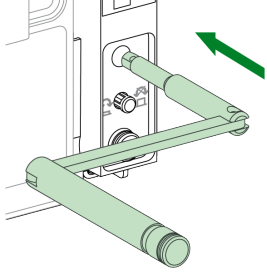
| Step | Action | |
|------|---|--|
| 1 | Put the key in the lock. |  |
| 2 | Turn the key clockwise to unlock the chassis. NOTE: The key remains captive in the keylock. |  |
| 3 | Check that the racking handle can be inserted into the racking handle socket. |  |

Chassis Locking in Any Position

Description

The chassis can be locked in any position (connected, test, or disconnected position).

This locking function requires a mechanical adaptation of the chassis, explained in the following procedure.

When the chassis is locked, the racking handle cannot be inserted in the racking handle socket.

The chassis can be locked in any position:

- By up to three padlocks with shackle diameter 5-8 mm as standard.
- By one or two optional keylocks.

Keylocks can be used in addition to padlocks.

VSPD Chassis Locking by Keylock Accessory

The chassis locking by keylock accessory and the locking and unlocking procedures are the same as for the chassis locking in disconnected position, page 60.

Adapting the Chassis

| |
|--|
| ⚠ DANGER |
| <p>HAZARD OF DEVICE FALLING</p> <ul style="list-style-type: none"> • Be sure that lifting equipment has lifting capacity for the device being lifted. • Follow manufacturer’s instructions for use of lifting equipment. • Wear hard hat, safety shoes, and heavy gloves. <p>Failure to follow these instructions will result in death or serious injury.</p> |

| |
|--|
| NOTICE |
| <p>HAZARD OF EQUIPMENT DAMAGE</p> <p>The chassis must be securely fastened when installing or removing the device.</p> <p>Failure to follow these instructions can result in equipment damage.</p> |

Follow this procedure to adapt the chassis locking mechanism so that the chassis can be locked in any position.

| Stage | Description |
|-------|--|
| 1 | Removing the terminal block identification plate and the chassis front cover, page 66. |
| 2 | Changing the position of the lock, page 67. |
| 3 | Reinstalling the chassis front cover and the terminal block identification plate, page 69. |

Removing the Terminal Block Identification Plate and the Chassis Front Cover

Before starting the procedure, check that the device is in the disconnected position, page 45 and remove the device from the chassis, page 49.

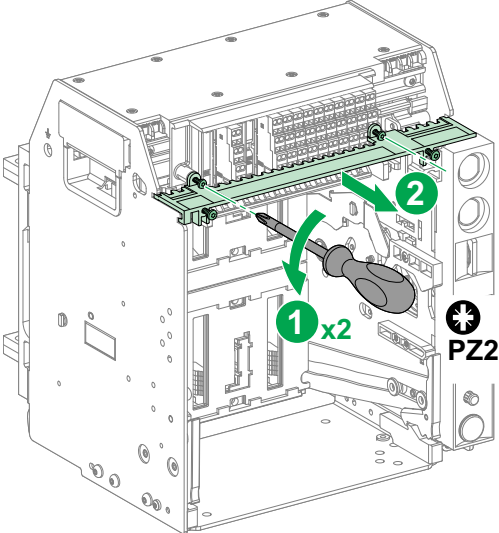
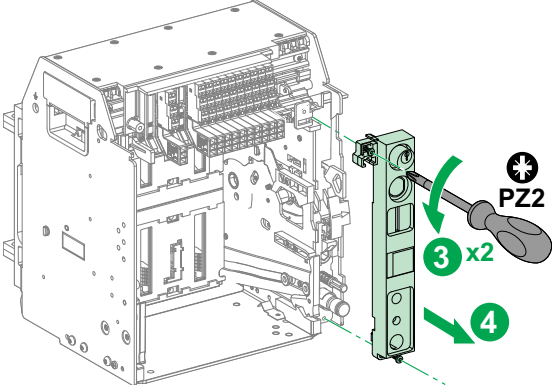
| Step | Action | |
|------|---|---|
| 1 | Remove the two screws holding the terminal block identification plate in place, by using a PZ2 screwdriver. |  |
| 2 | Carefully pull out the terminal block identification plate. | |
| 3 | Remove the two screws holding the chassis front cover in place, by using a PZ2 screwdriver. |  |
| 4 | Pull off the chassis front cover. | |

Changing the Position of the Lock

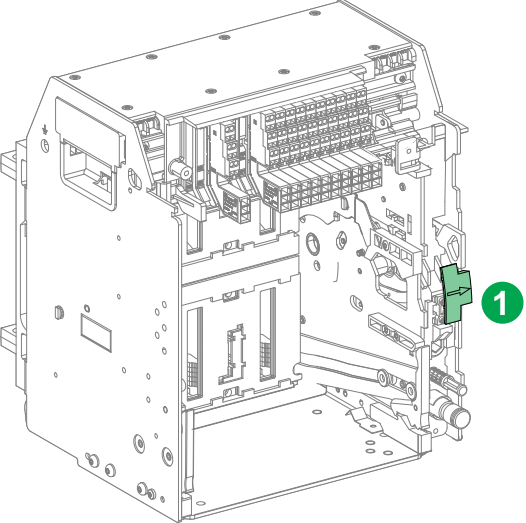
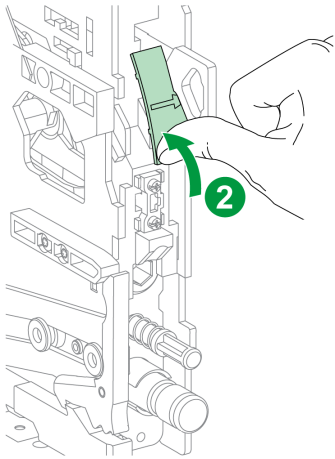
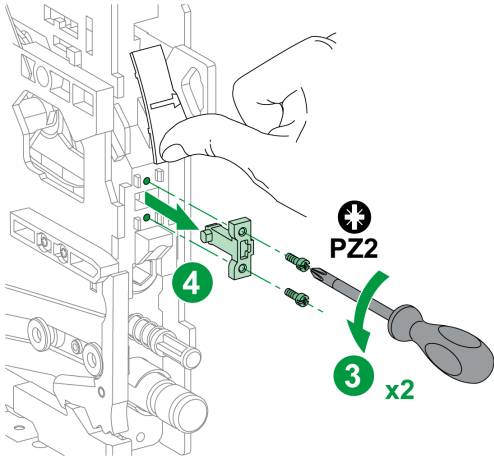
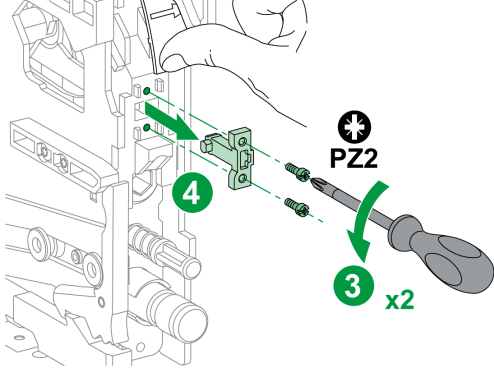
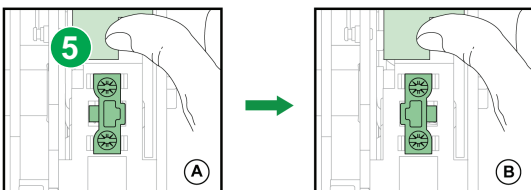
| Step | Action | |
|------|--|--|
| 1 | Identify the position of the plastic cover of the lock. |  |
| 2 | Lift the plastic cover of the lock and hold it up. |  |
| 3 | Remove the two screws holding the lock in place, by using a PZ2 screwdriver. |  |
| 4 | Remove the lock. |  |
| 5 | Rotate the lock through 180° to change from locking in disconnected position (A) to locking in any position (B). |  |

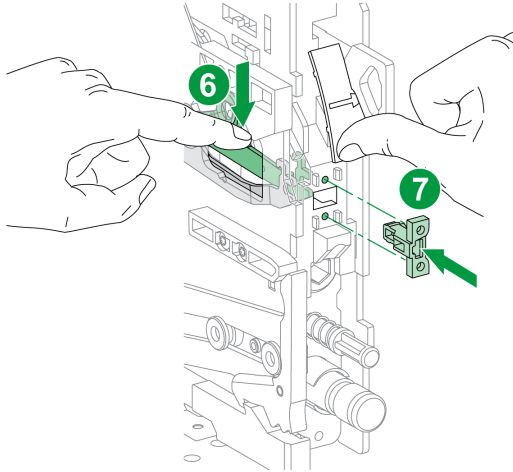
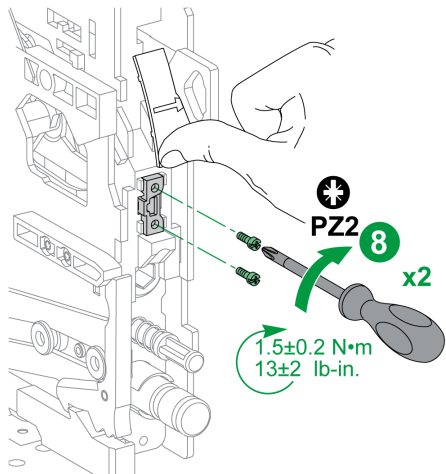
| Step | Action | |
|------|---|---|
| 6 | Use your finger to press down the tab behind the lock slot. | |
| 7 | Insert the lock, make sure that the notch is on the left side. |  |
| 8 | <p>Screw the lock into position with the two screws, by using a PZ2 screwdriver.</p> <p>Release the plastic cover to allow it to drop back into place</p> |  |

Reinstalling the Chassis Front Cover and the Terminal Block Identification Plate

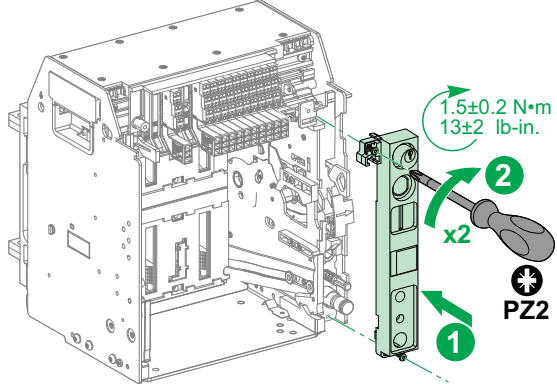
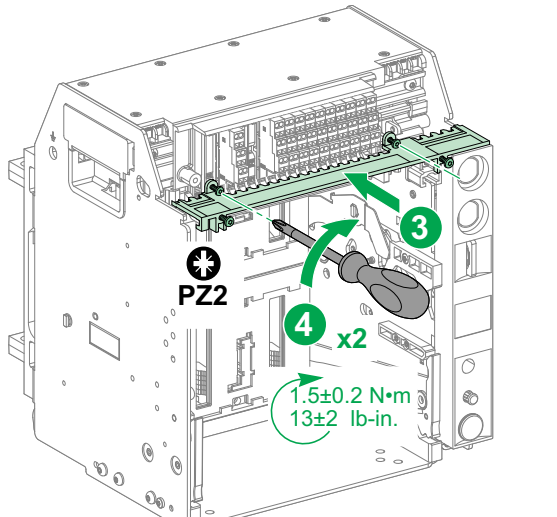
| Step | Action | |
|------|---|---|
| 1 | Reinstall the chassis front cover. | |
| 2 | Screw the front cover into position with the two screws, by using a PZ2 screwdriver. |  <p>1.5±0.2 N·m 13±2 lb-in.</p> <p>2</p> <p>x2</p> <p>PZ2</p> <p>1</p> |
| 3 | Slide the terminal block identification plate into place. | |
| 4 | Screw the terminal block identification plate in with the two screws, by using a PZ2 screwdriver. |  <p>PZ2</p> <p>3</p> <p>4</p> <p>x2</p> <p>1.5±0.2 N·m 13±2 lb-in.</p> |

Locking the Safety Shutters

Description

A shutter lock locks the safety shutter in closed position so that a drawout EasyPact MVS1 device cannot be connected in its chassis.

The top and bottom safety shutters can be locked independently.

Locking the Safety Shutters

Place two padlocks on the top and bottom shutter locking guides to lock the shutters.

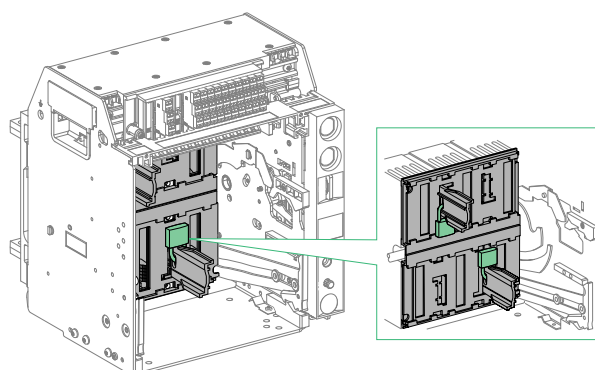

For information on the accessory installation, consult the instruction sheet on the Schneider Electric website: [MVS21737](#).

Device Interlocking Actions

What's in This Chapter

| | |
|---|----|
| VPEC Door Interlock | 72 |
| VPOC Open-door Racking Interlock | 75 |
| Mechanical Interlocking for Transfer Switches | 77 |

About Interlocking Actions

An interlocking action is an automatic locking operation provided by interlocking accessories added to the EasyPact MVS1 device or chassis.

A number of optional interlocking accessories are available for the EasyPact MVS1 device and chassis.

VPEC Door Interlock

Description

With the door interlock:

- The equipment door is locked and cannot be opened when the drawout device is in connected or test position.
- The equipment door can be opened when the drawout device is in disconnected position.
- The equipment door can be closed with the drawout device in any position.

Accessory

The VPEC door interlock accessory is an optional accessory that is mounted on the left side or on the right side of the chassis. One door interlock is necessary for each chassis.

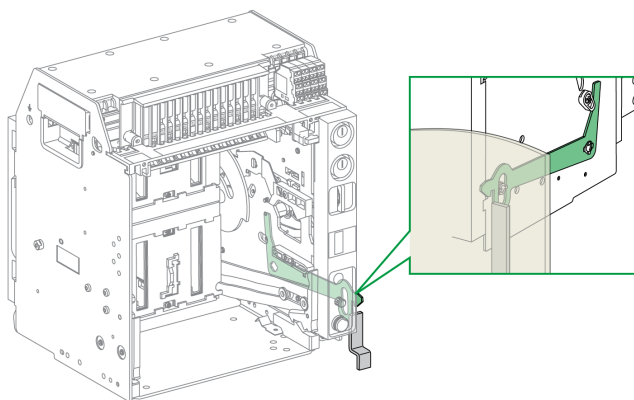

For information on the accessory installation, consult the instruction sheet available at Schneider Electric website: [MVS21737](#).

Locking the Equipment Door

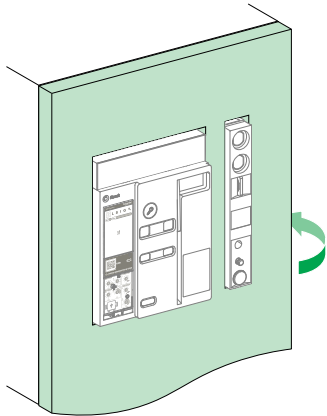
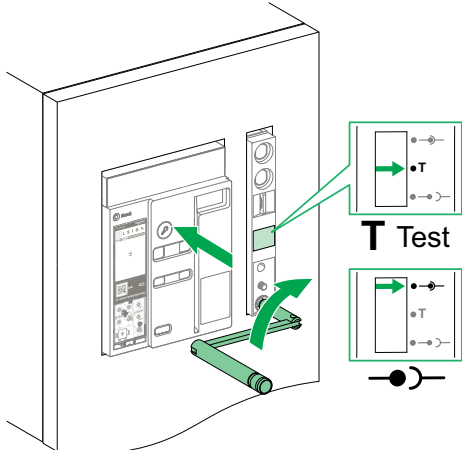
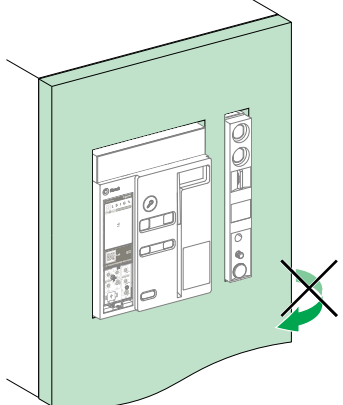
| Step | Action | |
|------|--|--|
| 1 | Close the equipment door. |  |
| 2 | Put the device into the test or connected position, page 47. |  |
| 3 | Check that the equipment door is locked. |  |

Unlocking the Equipment Door

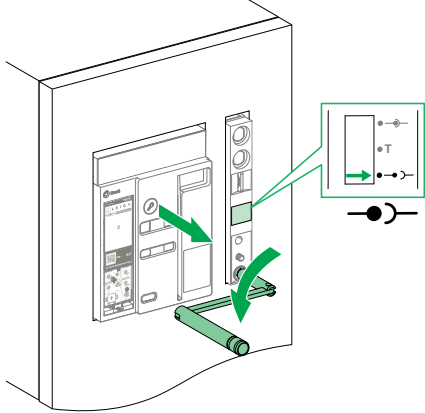
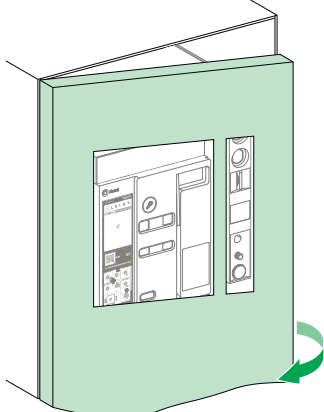
| Step | Action | |
|------|---|---|
| 1 | Put the device into the disconnected position, page 45. |  |
| 2 | Check that the equipment door is unlocked. |  |

VPOC Open-door Racking Interlock

Description

With the racking interlock installed, a drawout EasyPact MVS1 device cannot be racked in or out when the equipment door is open because the racking handle cannot be inserted.

Accessory

The optional VPOC racking interlock can be installed on the right side of the chassis.

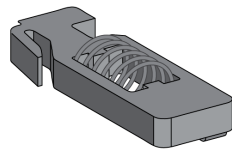

For information on the accessory installation, consult the instruction sheet on the Schneider Electric website: MVS21737.

Activating the Racking Interlock

| Step | Action | |
|------|-------------------------------|--|
| 1 | Remove the door. | |
| 2 | Insert the racking interlock. | |

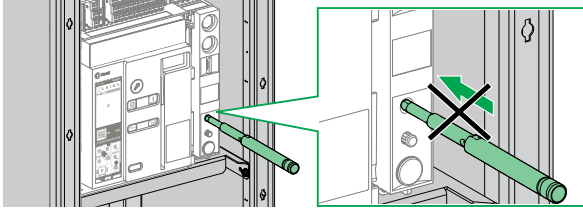
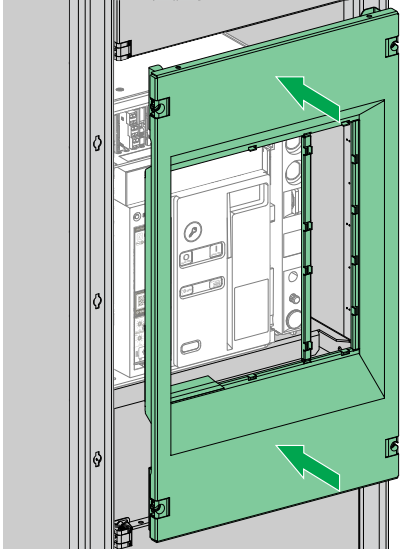
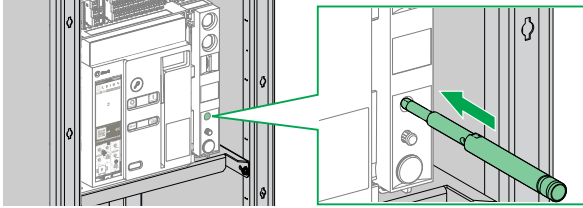
| Step | Action | |
|------|--|--|
| 3 | Check that the racking handle cannot be inserted into the racking handle socket when the equipment door is open. |  |
| 4 | Replace the door. |  |
| 5 | Check that the racking handle can be inserted into the racking handle socket when the equipment door is closed. |  |

Deactivating the Racking Interlock

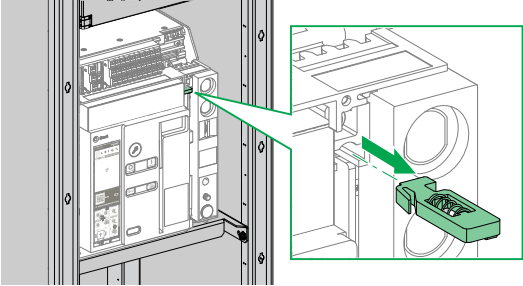
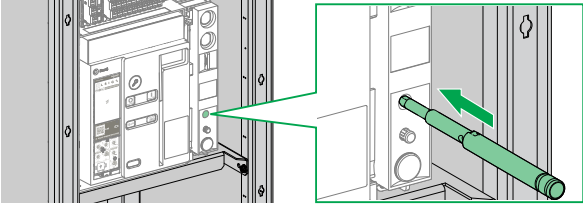
| Step | Action | |
|------|---|--|
| 1 | Pull out the racking interlock. |  |
| 2 | Check that the racking handle can be inserted into the racking handle socket when the equipment door is open or closed. |  |

Mechanical Interlocking for Transfer Switches

Description

The mechanical interlocking for transfer switches between EasyPact MVS1 devices prevents the interlocked devices from closing at the same time.

VBP Pushbutton Locking Accessory

The VBP pushbutton locking accessory provides redundancy in addition to the mechanical interlocking system.

The use of the pushbutton locking cover is mandatory on each interlocked EasyPact MVS1 device. The closing pushbuttons of the interlocked devices must be locked by padlocks sharing one key to help avoid simultaneous closing orders of interlocked devices.

For more information about the pushbutton locking cover, refer to VBP Pushbutton Locking Accessory, page 55.

Mechanical Interlocking Between Two Devices

Two devices can be mechanically interlocked by cables so that both devices cannot be closed at the same time.

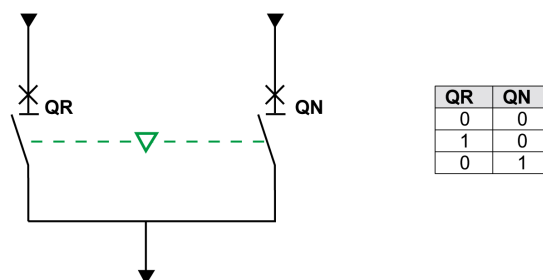

For information on the accessory installation, consult the instruction sheet on the Schneider Electric website: MVS21738.

IVE Electrical Interlocking Unit

Electrical interlocking between EasyPact MVS1 devices can be done using the IVE electrical interlocking unit or by using dedicated wiring. The IVE unit is suitable for two devices only. For three devices, dedicated wiring is required to perform the electrical interlocking.

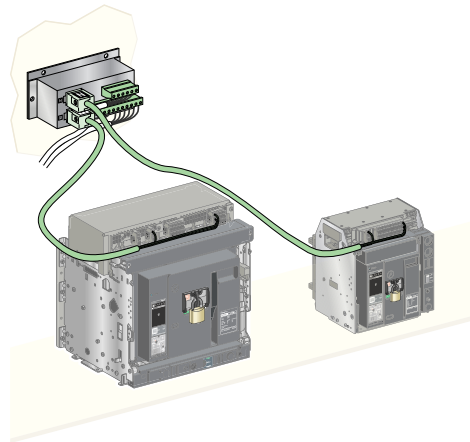

For information on the accessory installation, consult the instruction sheet on the Schneider Electric website: [51201201AA](https://www.schneider-electric.com/51201201AA).

EasyPact MVS Critical Cases

What's in This Part

| | |
|--|----|
| Finding the Cause of a Trip or an Alarm in Critical Cases | 80 |
| Resetting the Circuit Breaker After a Trip Due to an Electrical Fault | 82 |
| Resetting the Circuit Breaker After a Trip Due to an Incident Detected by TS | |
| Self-tests | 85 |
| Diagnosing Alarms | 86 |

Finding the Cause of a Trip or an Alarm in Critical Cases

Definitions

While operating the circuit breaker, the user may face two critical cases:

- The circuit breaker has tripped automatically, interrupting the power supply.
- The circuit breaker has not tripped, but the TS trip system has detected an alarm:
 - For a high severity alarm, the status bar is red, indicating that urgent corrective action is required.
 - For a medium severity alarm, the status bar is orange, indicating that corrective action needs to be scheduled.

Notification of a Trip or Alarm

A trip or alarm event is signaled:

- On the TS trip system, by the trip cause LEDs, the status bar and the service LED.
- By the SDE fault-trip indication contact.

Active alarms can also be consulted in the following ways:

- On a smartphone with EcoStruxure Power Device app connected to the TS trip system through NFC wireless communication.
- On a PC with EcoStruxure Power Commission software connected to the TS trip system through USB connection.

Identifying the Cause of a Trip or Alarm Using the TS Trip System

In critical situations, the cause of a trip or an alarm can be identified locally by using one of the following:

- The blue fault-trip reset button on the circuit breaker. When the trip button is popped out, the trip has occurred.
- The indication LEDs on the TS trip system.
- A smartphone with EcoStruxure Power Device app installed to get the trip cause, the trip or alarm context, and the circuit breaker ID through NFC wireless communication.

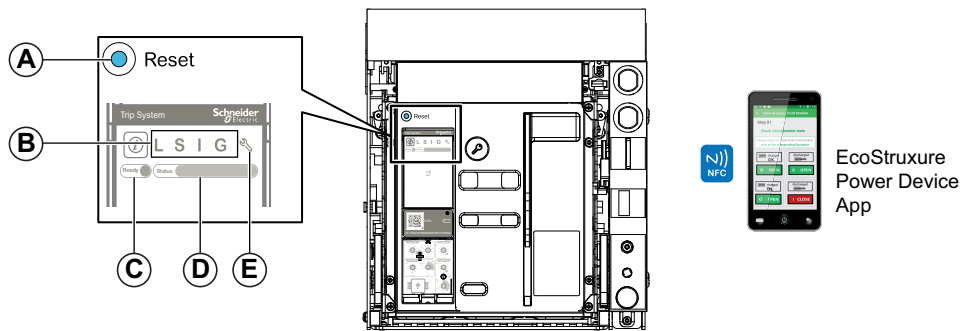

- A** Blue fault-trip reset button
- B** Trip cause and alarm LEDs
- C** Ready LED
- D** Status bar
- E** Service LED

Availability of Diagnostic Data After a Trip

Availability of diagnostic data after a trip depends on the TS state:

- If the TS trip system is operative, the trip data is available.
- If the TS trip system is inoperative, no data is directly available. However, some data can be extracted using the NFC wireless communication with the EcoStruxure Power Device app.

The trip cause LEDs, status bar and service LED are powered by the TS internal battery and remain on for 2 hours when there is no other power to the trip system. To switch on the trip cause LEDs or the service LED again after 2 hours, press the **i** button.

Procedure to Follow After Detection of a Trip or Alarm

The procedure to follow after detection of a trip or an alarm depends on the indications provided by the blue fault trip button and the indication LEDs on the TS trip system.

| Blue fault-trip reset button | Status bar | Indication LED | Description |
|------------------------------|------------------|---|---|
| Popped out | Blinking red | One trip cause LED is blinking red | Trip due to electrical fault, refer to the reset procedure, page 82 |
| Popped out | Blinking red | Service LED is blinking red | Trip due to internal malfunction, refer to the reset procedure, page 85 |
| Not popped out | Red or orange on | One trip cause LED or the Service LED is red on | Alarm detected, refer to Diagnosing Alarms, page 86 |

Resetting the Circuit Breaker After a Trip Due to an Electrical Fault

Reset Procedure

⚡⚠ DANGER

HAZARD OF ELECTRIC SHOCK, EXPLOSION, OR ARC FLASH

Do not re-close the device on an electrical fault. First inspect and, if necessary, repair the downstream equipment.

Failure to follow these instructions will result in death or serious injury.

The following table shows the sequence of actions to follow after a trip due to an electrical fault. Further explanation of each action is given in the following paragraphs.

| Step | Action |
|------|---|
| 1 | Identify the trip cause. |
| 2 | Clear the electrical fault on the network. |
| 3 | Check the load. |
| 4 | Inspect the circuit breaker and switchboard after a short circuit. |
| 5 | Reset the circuit breaker, page 38. |
| 6 | Press the i for 3 seconds to reset the latched events and switch off the trip cause LEDs and the status bar. |
| 7 | When the circuit breaker is ready-to-close, re-close it, page 37. |

Identifying the Trip Cause

When the circuit breaker is tripped due to an electrical fault, the blue fault-trip reset button on the circuit breaker is popped out, and the trip cause is indicated by the status bar and the trip cause LEDs.

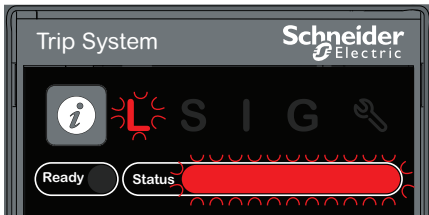
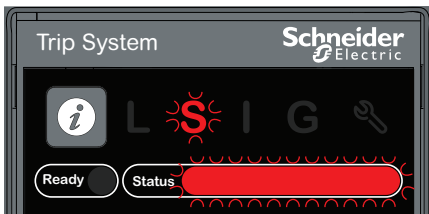
| Description | Indication LEDs | |
|-----------------------------------|---|--|
| Trip on long-time protection (L) |  | Ready LED: off Status bar: blinking red Service LED: off L trip cause LED: blinking red Other trip cause LEDs: off |
| Trip on short-time protection (S) |  | Ready LED: off Status bar: blinking red Service LED: off S trip cause LED: blinking red Other trip cause LEDs: off |

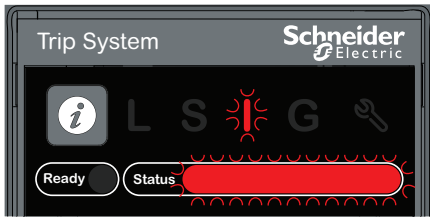
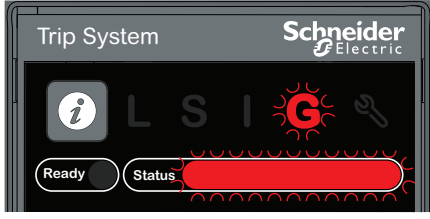
| Description | Indication LEDs | |
|--------------------------------------|--|--|
| Trip on instantaneous protection (I) |  | Ready LED: off Status bar: blinking red Service LED: off I trip cause LED: blinking red Other trip cause LEDs: off |
| Trip on ground-fault protection (G) |  | Ready LED: off Status bar: blinking red Service LED: off G trip cause LED: blinking red Other trip cause LEDs: off |

Clearing the Electrical Fault

⚡ ⚠ **DANGER**

HAZARD OF ELECTRIC SHOCK, EXPLOSION, OR ARC FLASH

- Apply appropriate personal protective equipment (PPE) and follow safe electrical work practices. See NFPA 70E or CSA Z462 or local equivalent.
- This equipment must be installed and serviced by qualified electrical personnel.
- Turn off all power supplying this equipment before performing maintenance inspections. Assume that all circuits are live until they are de-energized, tested, grounded, and tagged. Consider all sources of power, including the possibility of backfeeding and control power.
- Always use a properly rated voltage sensing device to confirm that power is off.
- Replace all devices, doors, and covers before turning on power to this equipment.
- Beware of potential hazards and carefully inspect the work area for tools and objects that may have been left inside the equipment.

Failure to follow these instructions will result in death or serious injury.

⚡ ⚠ **DANGER**

HAZARD OF ELECTRIC SHOCK, EXPLOSION, OR ARC FLASH

Do not re-close the device on an electrical fault. First inspect and, if necessary, repair the downstream equipment.

Failure to follow these instructions will result in death or serious injury.

The feed must be isolated before inspecting the electrical equipment downstream of the protection.

The fact that a circuit breaker has tripped does not remedy the cause of the electrical fault detected on the downstream electrical equipment.

Inspecting the Circuit Breaker after a Trip on Short Circuit

After a trip on short circuit due to short-time or instantaneous protection, the circuit breaker must be inspected for smoke deposits or cracks in the device casing.

Resetting the Circuit Breaker After a Trip Due to an Incident Detected by TS Self-tests

Reset Procedure

The following table shows the sequence of actions to follow after a trip due to a major malfunction is detected by the TS trip system. Further explanation of each action is given in the following paragraphs.

| Step | Action |
|------|--|
| 1 | Identify the trip cause. |
| 2 | Consult the active alarms by using: <ul style="list-style-type: none"> a smartphone with EcoStruxure Power Device app connected to the TS trip system through NFC wireless communication. a PC with EcoStruxure Power Commission software connected to the TS trip system: through USB connection. |
| 3 | Perform the actions recommended to restart after the trip. Refer to DOCA0299●● <i>EasyPact MVS - TS Trip System - User Guide</i> , page 7. |
| 4 | Reset the circuit breaker, page 38. |
| 5 | Press the i for 3 seconds to reset the latched events and switch off the trip cause LEDs and the status bar. |
| 6 | When the circuit breaker is ready-to-close, re-close it, page 37. |

Identifying the Trip Cause

When the circuit breaker is tripped due to the detection of a major internal malfunction, the blue fault-trip reset button on the circuit breaker is popped out, and the trip cause is indicated by the status bar and the service LED.

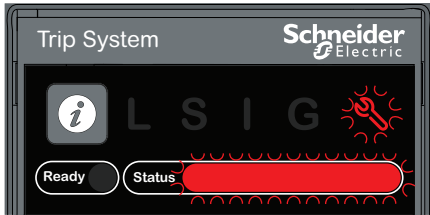
| Description | Indication LEDs | |
|-------------------------------------|--|---|
| Major internal malfunction detected |  | Ready LED: off Status bar: blinking red Service LED: blinking red All trip cause LEDs: off |

Diagnosing Alarms

Diagnosis Procedure

The following table shows the sequence of actions to take after an alarm is detected by the TS trip system. Further explanation of each action is given in the following paragraphs.

| Step | Action |
|------|--|
| 1 | Identify the alarm detected. |
| 2 | Consult the active alarms by using: <ul style="list-style-type: none"> • a smartphone with EcoStruxure Power Device app connected to the TS trip system through NFC wireless communication. • a PC with EcoStruxure Power Commission software connected to the TS trip system: through USB connection. |
| 3 | Perform the recommended actions described in DOCA0299●● <i>EasyPact MVS - TS Trip System - User Guide</i> , page 7. |
| 4 | Press the i button for 3 seconds to reset the latched events and switch off the trip cause LEDs and the status bar. |

Identifying the Alarm Detected

The TS trip system indicates alarms with:

- The status bar is on red for high-severity detected alarms
- The status bar is on orange for medium-severity detected alarms

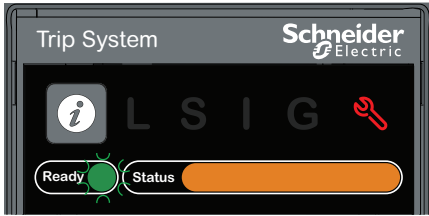
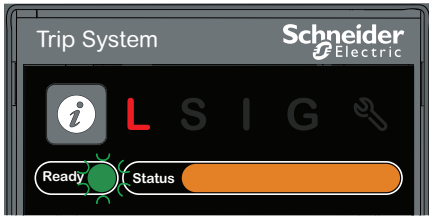
| Description | Indication LEDs | |
|--|---|--|
| Major or minor internal malfunction detected, corrective action to be planned. |  | Ready LED: blinking green Status bar: orange on Service LED: red on All trip cause LEDs: off |
| Overload pre-alarm: 90% I _r < Phase current < 105% I _r |  | Ready LED: blinking green Status bar: orange on Service LED: off L trip cause LED: red on Other trip cause LEDs: off |

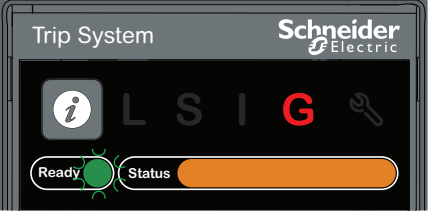
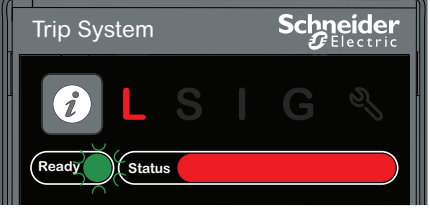
| Description | Indication LEDs | |
|---|--|--|
| Ground fault alarm: I_g current $\geq 80\% I_g$ |  | Ready LED: blinking green Status bar: orange on Service LED: off G trip cause LED: red on Other trip cause LEDs: off |
| Overload alarm: current $\geq 105\% I_r$ |  | Ready LED: blinking green Status bar: red on Service LED: off L trip cause LED: red on Other trip cause LEDs: off |

For more information, refer to the event messages in DOCA0299●● *EasyPact MVS - TS Trip System - User Guide*, page 7.

EasyPact MVS Commissioning

What's in This Part

| | |
|-------------------------------------|----|
| Introduction to Commissioning | 89 |
| Inspection and TS Settings | 91 |
| Tests | 93 |
| Final Checks and Reporting | 97 |
| EasyPact MVS Test Form | 98 |

Introduction to Commissioning

Overview

⚠️⚠️ DANGER

HAZARD OF ELECTRIC SHOCK, EXPLOSION, OR ARC FLASH

- Apply appropriate personal protective equipment (PPE) and follow safe electrical work practices. See NFPA 70E, CSA Z462, NOM 029-STPS, or local equivalent.
- This equipment must only be installed and serviced by qualified electrical personnel.
- Unless specified otherwise in the commissioning procedures, all operations (inspection, test, and preventive maintenance) must be carried out with the device, the chassis, and the auxiliary circuits de-energized.
- Check that the device and the chassis are de-energized on the upstream and downstream terminals.
- Always use a properly rated voltage sensing device to confirm that the device, the chassis, and the auxiliary circuits are de-energized.
- Install safety barriers and display a danger sign.
- During the tests, it is strictly forbidden for anyone to touch the device, the chassis, or the conductors while voltage is applied.
- Before putting the equipment back into operation, it is mandatory to check that all connections are made with the correct tightening torque, there are no tools or objects inside the equipment, all devices, doors, and protective covers are in position, and the device is off (open position).

Failure to follow these instructions will result in death or serious injury.

This part details the testing and commissioning procedure for EasyPact MVS circuit breakers that must be done before the circuit breaker can be accepted as fit for service and connected to a power supply.

The commissioning procedure must be done by an authorized commissioning engineer with appropriate training and experience:

- Only qualified electrical personnel with training and experience on low voltage circuits must perform the work described in this chapter.

Personnel must understand the hazards involved in working with or near low-voltage equipment. Such work must be performed only after reading the complete set of instructions.

- Some inspections or procedures require that certain parts of the electrical system remain energized at hazardous voltage during the procedure. Observe all safety messages (Danger, Warning, Caution) throughout this chapter and the corresponding instruction notices.
- Wear personal protective equipment, recognize potential hazards, and take adequate safety precautions when performing the procedures outlined in this chapter and the corresponding instruction notices.

The commissioning procedure assumes that the following conditions are met at the start of the procedure:

- The circuit breaker is not connected to a power system or a control system.
- A drawout circuit breaker is in the disconnected position.

The results of all observations, tests, adjustments, together with any relevant comments must be recorded on the appropriate form, if applicable.

Wherever possible, testing must be done without disconnecting or disturbing existing wiring.

Scope

The commissioning procedure applies to the EasyPact MVS intelligent modular unit (IMU), made up of EasyPact MVS circuit breaker with its TS trip system.

The associated information, which must be read with this procedure, includes specific schematic diagrams, connections, and trip levels for the circuit breakers covered by this document.

Equipment

The following equipment is required to do the tests detailed in the commissioning procedure:

- Insulation resistance tester
- Multimeter
- A PC equipped with the latest version of EcoStruxure Power Commission software
- A function test and isolation module (commercial reference - LV910200SP) to connect the PC to the TS trip system

Test Form

A Test Form, page 98 is proposed to guide you through the commissioning procedure and to record the results of the commissioning tests. Each test is described in detail in the Commissioning chapter.

Only do the tests required, depending on the EasyPact MVS type and the functions in use.

Inspection and TS Settings

Visual Inspection

| Step | Action |
|------|---|
| 1 | Record the equipment identification, including substation name, switchboard name, EasyPact MVS circuit breaker type, TS model type and serial number, TS type, and protection settings. |
| 2 | Check that the circuit breaker is undamaged, correctly mounted, and securely fastened in the switchboard. |
| 3 | Check the 3-phase clearance at terminal blocks. |
| 4 | Check that there is no debris remaining at the back of the circuit breaker housing/ enclosure. |
| 5 | Check that the ground terminals of the circuit breaker are securely connected with the correct grounding cables. |
| 6 | Check that all external surfaces are undamaged. |
| 7 | Rectify any non-conformities, if possible. All equipment non-conformities must be referred to asset management. |

Condition of Connections and Auxiliaries

Check circuit breaker mounting in the switchboard and the tightness of all connections (main connection and auxiliary wiring).

Check that all auxiliaries and accessories are correctly installed:

- Electrical auxiliaries
- Terminal blocks
- Connections of auxiliary circuits

Check Firmware Compatibility

By using the latest version of EcoStruxure Power Commission software, check that the firmware of the TS trip system is up to date.

| Step | Action |
|------|---|
| 1 | Connect a PC running EcoStruxure Power Commission software by using the function test and isolation module connected to the 5-pin plug on the front face of the TS trip system. |
| 2 | Establish a connection. EcoStruxure Power Commission software reads the parameters of the trip system. |
| 3 | On EcoStruxure Power Commission, use the Overall System firmware status/ compatibility matrix to display: <ul style="list-style-type: none"> • The latest firmware version of the trip system that are available on the Schneider Electric System Updates Internet site. • The recommended actions to get a compatible system. For more information, refer to <i>EcoStruxure Power Commission Online Help</i> . |
| 4 | Follow the recommended actions to get a compatible system. |

TS Settings

NOTICE

RISK OF UNINTENDED OPERATION

- The device must only be configured and set by qualified personnel, using the results of the installation protection system study.
- During commissioning of the installation and following any modification, check that the TS configuration and protection function settings are consistent with the results of this study.
- TS protection functions are set by default to the minimum value, except for the long time protection function which is set to the maximum value, by default.

Failure to follow these instructions can result in equipment damage.

Check the settings with EcoStruxure Power Commission software connected to the TS trip system.

| Step | Action |
|------|---|
| 1 | Connect a PC running EcoStruxure Power Commission software by using the function test and isolation module connected to the 5-pin plug on the front face of the TS trip system. |
| 2 | Establish a connection. EcoStruxure Power Commission software reads the parameters of the trip system. |
| 3 | Check that the settings read in the trip system match the requirements of the application. If necessary, correct the protection settings by using the rotary switches on the front face of the TS trip system. <ul style="list-style-type: none"> • The protection settings must be defined according to the installation protection system study. • Other settings must be defined according to the application. |
| 4 | Complete the project and circuit breaker data. |
| 5 | Generate the project report with EcoStruxure Power Commission software, and save or print the project report as needed. |

NOTE: The protection functions available depend on the type of TS trip system.

Tests

Overview

The tests to do while commissioning an MVS circuit breaker are described in this section:

- Functional checks
- Check of MCH gear motor (if fitted)
- Check of electrical continuity
- Check of high-voltage insulation
- Check of TS indication LED status
- Test of the tripping mechanism with EcoStruxure Power Commission software
- Test of the tripping mechanism with the test button (TS 6.0S trip systems)
- Automatic trip curve test with EcoStruxure Power Commission software

Only do the tests required, depending on the EasyPact MVS type and the functions in use, and record the results on the [EasyPact MVS Test Form](#), page 98. In the event of non-conformance, the result must be recorded and the EasyPact MVS circuit breaker must not be accepted into service.

Functional Checks

Follow this procedure to check the operation of the EasyPact MVS circuit breaker and record the results on the test form.

| Step | Action |
|------|--|
| 1 | Manually charge the mechanism by pulling the spring charging handle down. |
| 2 | Close the circuit breaker. Check the closing of the circuit breaker in each of the different means designed for the application. |
| 3 | Open the circuit breaker. Check the opening of the circuit breaker in each of the different means designed for the application. |

If the circuit breaker does not close or does not open, refer to [EasyPact MVS Troubleshooting](#), page 101.

Check of MCH Gear Motor (if Fitted)

Follow this procedure to check the operation of the MCH gear motor and record the results on the test form.

| Step | Action |
|------|---|
| 1 | Remove the MCH gear motor power supply. |
| 2 | Do an opening/closing/opening cycle to discharge the mechanism. |
| 3 | With the circuit breaker in the open position and the mechanism discharged, check electrical continuity between terminals B1 and B2, and electrical non-continuity between terminals B1 and B3. |
| 4 | Manually charge the mechanism. |
| 5 | Reconnect the MCH gear motor power supply. The circuit breaker closes and the mechanism is automatically charged. |
| 6 | Check electrical continuity between terminals B1 and B3. |
| 7 | Operate the circuit breaker several times to check that the spring mechanism automatically recharges after every closing operation. |

Check of Electrical Continuity

Follow this procedure to check electrical continuity using a multimeter or continuity checker and record the results on the test form.

| Step | Action |
|------|--|
| 1 | Close the circuit breaker. |
| 2 | Check electrical continuity, for each of the phases, between the upper and lower power terminals: <ul style="list-style-type: none"> • For fixed circuit breaker: on the power terminals • For the drawout circuit breaker: on the chassis power terminals, with the circuit breaker in the connected position |

Check of High-Voltage Insulation

Dielectric tests (high potential and insulation resistance tests) are used to check the insulation between phases, and insulation between each phase and ground. The equipment used to conduct these tests creates a high potential voltage (thousands of volts) to check dielectric or insulation integrity.

Follow this procedure to check insulation resistance and record the results on the test form.

| Step | Action |
|------|---|
| 1 | Unplug any cables from the 5-pin port on the front face of the TS trip system. |
| 2 | Close the EasyPact MVS circuit breaker. |
| 3 | Measure the insulation resistance using a 500 Vdc insulation resistance tester between one of the phases and the other two phases grounded. Repeat for each phase. |
| 4 | Open the EasyPact MVS circuit breaker by pressing the opening pushbutton. |
| 5 | Measure the insulation resistance using a 500 Vdc insulation resistance tester between one of the phases and ground, with all other phases grounded. Repeat for each phase. |
| 6 | Check that the insulation resistance is above 5 MΩ in each case. If this result is not obtained, contact your field service representative. |

Check of TS Ready LED Status

Follow this procedure to check the functioning of the TS trip system and record the results on the test form.

| Step | Action |
|------|--|
| 1 | Provide power to the TS trip system, for example, by connecting a PC to the 5-pin port on the front face. |
| 2 | Check that the TS Ready LED is flashing green. The Ready LED flashes green to indicate that: <ul style="list-style-type: none"> • The sensors are correctly wired. • The tripping mechanism is functioning correctly. • The TS trip system is functioning correctly. |
| 3 | If the Ready LED is not flashing green, refer to EasyPact MVS Critical Cases, page 79. |

Test of the Tripping Mechanism With EcoStruxure Power Commission Software

Follow this procedure to test the tripping mechanism of the circuit breaker and record the results on the test form.

| Step | Action |
|------|---|
| 1 | Close the circuit breaker. |
| 2 | Connect a PC running EcoStruxure Power Commission software by using the function test and isolation module connected to the 5-pin plug on the front face of the TS trip system. |
| 3 | On EcoStruxure Power Commission software, select the circuit breaker and connect to it. |
| 4 | Force the circuit breaker to trip by clicking the Force Trip button on the EcoStruxure Power Commission screen. This action is password-protected. |
| 5 | Check that the circuit breaker is open. |
| 6 | Check that the blue fault-trip reset button has popped out. |
| 7 | Check that one trip cause LED is on. |
| 8 | Check that the SDE contacts have switched. |
| 9 | After the test, reset the circuit breaker. |

Test of the Tripping Mechanism with the Test Button (TS 6.0S Trip Systems)

Follow this procedure to test the tripping mechanism of the circuit breaker when fitted with a TS 6.0S trip system, and record the results on the test form.

| Step | Action |
|------|--|
| 1 | Close the circuit breaker. |
| 2 | Use a thin screwdriver to briefly push in (<1 s) the test button on the trip system. |
| 3 | Check that the circuit breaker is open. |
| 4 | Check that the blue fault-trip reset button has popped out. |
| 5 | Check that the G trip cause LED is on. |
| 6 | Check that the SDE contacts have switched. |
| 7 | After the test, reset the circuit breaker. |

Automatic Trip Curve Test With EcoStruxure Power Commission Software

Follow this procedure to run the automatic trip curve test and record the results on the test form.

| Step | Action |
|------|---|
| 1 | Close the circuit breaker. |
| 2 | If the circuit breaker is equipped with an MN undervoltage release, either connect it to the power supply with its rated voltage or remove the MN undervoltage release. |
| 3 | Connect a PC running EcoStruxure Power Commission software by using the function test and isolation module connected to the 5-pin plug on the front face of the TS trip system. |

| Step | Action |
|------|---|
| 4 | On EcoStruxure Power Commission software, select the circuit breaker and connect to it. |
| 5 | In the Circuit breaker Check up section, click the Circuit breaker tab. |
| 6 | Select the Automatic Trip Test section. |
| 7 | Select Preconfigured test point . |
| 8 | Select the overcurrent protection to be tested. |
| 9 | Click Run Test . |
| 10 | Check that the circuit breaker trips. |
| 11 | Check that the blue fault-trip reset button has popped out |
| 12 | Check that the related trip cause LED is lit. |
| 13 | Check the SDE contacts have switched. |
| 14 | After the test, reset the circuit breaker. |

Final Checks and Reporting

Final Checks

After completing the commissioning tests, check the following:

| Step | Action |
|------|---|
| 1 | Check that connections are made with the correct tightening torque, that there are no tools or objects inside the equipment, and that all circuit breakers, doors, and protective covers are in position. |
| 2 | Check that the circuit breaker is off (open position) and the closing spring is charged. |

Project Report Generated by EcoStruxure Power Commission Software

EcoStruxure Power Commission software generates a project report with a list of the circuit breakers for that project. For each EasyPact MVS circuit breaker it provides the following information:

- The circuit breaker identification data
- The TS identification data
- The protection settings for the TS trip system
- The alarm settings

EasyPact MVS Test Form

How to Use the Test Form

Print this test form to record the results of the commissioning tests.

Check the box (✓) when the test has been made and is conclusive.

This test form, the project report, and the communication test report should be left on-site in a plastic wallet and in an easily accessible, safe place.

Each test is described in detail in the Commissioning chapter.

Only do the tests required, depending on the EasyPact MVS type and the functions in use.

When all the tests have been satisfactorily completed, sign and date the test form.

Identification

| | | |
|--------------------------------------|----------------------------|-------------------|
| Workstation | Tests conducted on: | By: |
| | | Signature: |
| Substation name | Comments: | |
| Substation number | | |
| Switchboard name | | |
| Voltage | | |
| EasyPact MVS circuit breaker | | |
| Manufacturer | Schneider Electric | |
| Type of EasyPact MVS circuit breaker | | |
| Serial number | | |
| Hardware version | | |
| TS trip system | | |
| TS type | CT ratio | |
| Firmware version | | |

Preliminary Checks

| | |
|---|-----|
| Type of check | (✓) |
| Visual inspection satisfactory (for example, no visible signs of damage). | |
| Grounding satisfactory. | |
| Connection tightness checked. | |
| Firmware compatibility satisfactory. | |

| | |
|---------------------------|-----|
| Type of check | (✓) |
| TS settings applied. | |
| Project report generated. | |

Functional and Interlock Checks

| | |
|--|-----|
| Type of check | (✓) |
| Mechanism charges when spring charging handle is pulled. | |
| EasyPact MVS circuit breaker closes. | |
| EasyPact MVS circuit breaker opens. | |
| Mechanism charges automatically after closing when the circuit breaker is fitted with an MCH gear motor. | |
| Interlocking systems of the circuit breaker function correctly. | |
| Interlocking systems between two or three circuit breakers function correctly. | |

Electrical Continuity Check

| EasyPact MVS circuit breaker status | Tested terminals | | Electrical continuity |
|-------------------------------------|------------------|---------------|-----------------------|
| | Incoming side | Outgoing side | |
| Closed | L1 | L1 | Ω |
| Closed | L2 | L2 | Ω |
| Closed | L3 | L3 | Ω |

EasyPact MVS Insulation Test

| EasyPact MVS circuit breaker status | Terminals under test | Voltage | Insulation resistance |
|-------------------------------------|--|---------|-----------------------|
| Closed | L1, with L2 and L3 grounded | 500 Vdc | MΩ |
| Closed | L2, with L1 and L3 grounded | 500 Vdc | MΩ |
| Closed | L3, with L1 and L2 grounded | 500 Vdc | MΩ |
| Open | L1, with L1, L2, L3 grounded on the other side | 500 Vdc | MΩ |
| Open | L2, with L1, L2, L3 grounded on the other side | 500 Vdc | MΩ |
| Open | L3, with L1, L2, L3 grounded on the other side | 500 Vdc | MΩ |

Check of TS Ready LED

| | |
|------------------------------|-----|
| Type of check | (✓) |
| TS Ready LED blinking green. | |

Test of the Tripping Mechanism for TS Trip Systems

| | |
|---|-----|
| Type of check | (✓) |
| With the circuit breaker closed, force the circuit breaker to trip using EcoStruxure Power Commission software. | |
| Check that the circuit breaker is open. | |
| Check that the blue fault-trip reset button has popped out. | |
| Check that the I or S trip cause LED is on. | |
| Check that the SDE contacts have switched. | |

Test of the Tripping Mechanism for TS 6.0S Trip System

| | |
|---|-----|
| Type of check | (✓) |
| With the circuit breaker closed, briefly press (<1 s) the test button on the front face of the trip system. | |
| Check that the circuit breaker is open. | |
| Check that the blue fault-trip reset button has popped out. | |
| Check that the G trip cause LED is on. | |
| Check that the SDE contacts have switched. | |

Automatic Trip Curve Test

| | |
|---|-----|
| Type of check | (✓) |
| Check that the circuit breaker trips. | |
| Check that the blue fault-trip reset button has popped out. | |
| Check that the related trip cause LED is on. | |
| Check that the SDE contacts have switched. | |

Final Checks

| | |
|---|-----|
| Type of check | (✓) |
| All doors and protected covers are in position. | |
| The circuit breaker is off (open position) and the closing spring is charged. | |

EasyPact MVS Troubleshooting

What's in This Part

| | |
|--|-----|
| Introduction to Troubleshooting | 102 |
| Troubleshooting: Chassis Operation | 103 |
| Troubleshooting: Unexpected Tripping | 104 |
| Troubleshooting: Mechanical Control Operations | 105 |
| Troubleshooting: Electrical Control Operations | 106 |

Introduction to Troubleshooting

Presentation

This part contains information for troubleshooting problems in a working system. It assumes that the system is correctly installed and that all the commissioning tests have been completed successfully. The troubleshooting operations are described under the following headings:

- Chassis operation
- Unexpected tripping
- Mechanical control operations
- Electrical control operations

Layer Model

When troubleshooting the circuit breaker, it is useful to consider a layer model. There are two layers:

- Electrical
- Mechanical

The following diagram shows the layers in the circuit breaker:

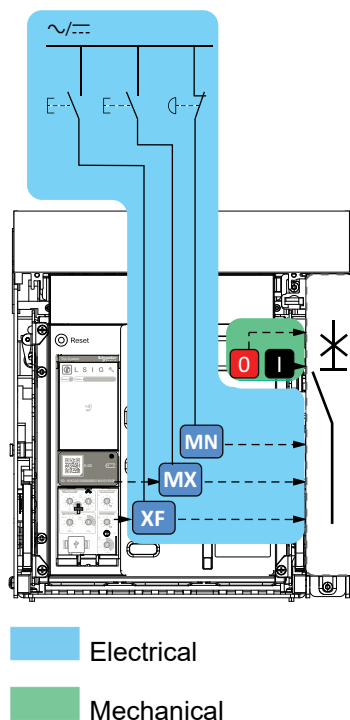

If the troubleshooting actions for a layer are not successful, go to the next layer until you reach the Mechanical layer. If you cannot solve the problem after troubleshooting the Mechanical layer, contact your field service representative.

Maintenance of the Circuit Breaker

Schneider Electric recommends a preventive maintenance program to ensure that circuit breakers retain the operating and technical characteristics specified in the catalogs during their service life. Maintenance must be carried out by trained and qualified personnel.

Troubleshooting: Chassis Operation

Definition

Chassis operation includes the following:

- Racking in and racking out the drawout circuit breaker
- Locking and unlocking the chassis

Troubleshooting

| Problem description | Probable causes | Solutions |
|---|---|---|
| Impossible to insert the racking handle in connected, test, or disconnected position. | A padlock or keylock is present on the chassis or a door interlock is present. | Disable the locking function. |
| Impossible to turn the racking handle. | The position release button is not pushed in and so the racking handle cannot be rotated. | Push the position release button. |
| Circuit breaker cannot be removed from chassis. | Circuit breaker is not in the disconnected position. | Turn the racking handle until the circuit breaker is in the disconnected position and the position release button pops out. |
| | Rails are not completely extended. | Pull out the rails of the chassis. |
| Circuit breaker cannot be connected (racked in). | Chassis and circuit breaker do not match (mismatch protection). | Check that the chassis corresponds with the circuit breaker. |
| | Safety shutters are locked. | Remove the locks. |
| | Disconnecting contact clusters are incorrectly positioned. | Reposition the disconnecting contact clusters. |
| | Chassis is locked in the disconnected position. | Disable the chassis locking function. |
| | The position release button is not pushed in and so the racking handle cannot be rotated. | Push the position release button. |
| | Circuit breaker has not been sufficiently inserted in the chassis. | Insert the circuit breaker completely so that it is engaged in the racking mechanism. |
| Circuit breaker cannot be locked in the disconnected position. | Circuit breaker is not in the correct position. | Check the circuit breaker position by checking that the position release button is popped out. |
| | Racking handle is still in the chassis. | Remove the racking handle and store it. |
| Circuit breaker cannot be locked in the connected, test, or disconnected position. | Locking in any position is not enabled. | Adapt the chassis locking mechanism so that the chassis can be locked in any position. |
| | Circuit breaker is not in the correct position. | Check the circuit breaker position by checking that the position release button is out. |
| | Racking handle is still in the chassis. | Remove the racking handle and store it. |
| The racking handle cannot be inserted to connect or disconnected the circuit breaker. | Rails are not completely in. | Push the rails all the way in. |
| The right-hand rail (chassis alone) or the circuit breaker cannot be drawn out. | Racking handle is still in the chassis. | Remove the racking handle and store it. |

Troubleshooting: Unexpected Tripping

Definition

Unexpected tripping is tripping that is not caused by a protection function during normal operation or by tests.

Troubleshooting



| Problem description | Symptom | Probable causes | Solutions |
|---|--|--|--|
| Circuit breaker opened without any over-current electrical fault. | The blue fault-trip reset button is not popped out and no trip cause LED is lit. | Drop in voltage to below the threshold detected by MN undervoltage release. | Check the voltage and the MN supply circuit ($V > 0.85 U_n$). |
| | | An order (for example load-shedding) sent to the MX opening voltage release by another circuit breaker. | Check the parameters of the circuit breaker that sent the order. |
| | | Unnecessary opening order from the MX opening voltage release. | Determine the origin of the order and cancel it. |
| Circuit breaker trips in a shorter time than expected after attempt to close the circuit breaker. | The blue fault-trip reset button is popped out and the L trip cause LED is blinking red. | Thermal memory is still active and current on the line is above the I_r threshold. | Check whether there is still an overload on the line. |
| Immediate tripping after an attempt to close the circuit breaker. | The blue fault-trip reset button is popped out and the L trip cause LED is blinking red. | Transient overcurrent when closing. | <ul style="list-style-type: none"> Modify the distribution system or the trip system settings. Check the condition of the circuit breaker before putting it back into service. |
| Immediate tripping after an attempt to close the circuit breaker with activation of the blue fault-trip reset button. | – | Closing on a short-circuit. | Refer to EasyPact MVS Critical Cases, page 79. |
| Nuisance tripping of the circuit breaker with activation of the blue fault-trip reset button. | – | Blue fault-trip reset button is not pushed-in completely. | Push in the blue fault-trip reset button completely. |
| | – | Transient overcurrent detected on the line and fast instantaneous trip setting is active in EcoStruxure Power Commission software. | Intended behavior. If necessary, adjust the settings in EcoStruxure Power Commission software. |

Troubleshooting: Mechanical Control Operations

Definition

Mechanical control operations are operations that are made using the opening or closing pushbuttons.

Circuit Breaker Cannot be Closed by Using the Mechanical Closing pushbutton

| Symptom | Probable causes | Solutions |
|---|--|---|
| The blue fault-trip reset button is popped out. | The blue fault-trip reset button has not been reset. | <ul style="list-style-type: none"> Clear the fault. Push the blue fault-trip reset button. |
| - | Circuit breaker is padlocked or keylocked in the open position. | Unlock the circuit breaker. |
| - | Circuit breaker is interlocked mechanically in a mechanical interlocking system. | <ul style="list-style-type: none"> Check the position of the other circuit breaker in the changeover system. Modify the situation to release the interlock. |
| The closing spring and ready-to-close indicator shows that the mechanism is discharged.  | Stored energy mechanism is not charged. | <ul style="list-style-type: none"> Charge the mechanism manually. If the circuit breaker is equipped with an MCH gear motor, check the supply of power to the motor. If the problem persists, replace the MCH gear motor. |
| The closing spring and ready-to-close indicator shows that the mechanism is charged but the circuit breaker is not ready to close.  | MX opening voltage release is permanently powered. | As there is an opening order, determine the origin of the order. The order must be canceled before the circuit breaker can be closed. |
| | MN undervoltage release is not powered due to an opening order. | As there is an opening order, determine the origin of the order. The order must be canceled before the circuit breaker can be closed. |
| | MN undervoltage release is not powered due to insufficient voltage power supply. | Check the voltage and the MN supply circuit ($V > 0.85 U_n$). If the problem persists, replace the MN undervoltage release. |
| The position release button on the chassis of the drawout circuit breaker is pushed in. | Circuit breaker is not correctly connected. | Terminate racking in (connection) of the circuit breaker, making sure that it is fully inserted in the chassis, to the connected position. Check that the position release button is popped out. |

Circuit Breaker Cannot be Opened by Using the Mechanical Opening pushbutton

| Probable causes | Solutions |
|--|--|
| Operating mechanism incident or welded contacts. | Contact your field service representative. |

Troubleshooting: Electrical Control Operations

Definition

Electrical control operations are operations that are made by an electrical order through a voltage release or by an external pushbutton that is directly connected to a voltage release.

Circuit Breaker Cannot be Closed by Using an External Pushbutton/Electrical Order

| Symptom | Probable causes | Solutions |
|---|---|---|
| – | Circuit breaker is padlocked or keylocked in the open position. | Unlock the circuit breaker. |
| – | Electrical closing order not executed by the XF closing voltage release due to insufficient voltage power supply. | Check the voltage and the XF supply circuit (0.85–1.1 Un). If the problem persists, replace the XF closing voltage release. |
| The closing spring and ready-to-close indicator shows that the mechanism is charged but the circuit breaker is not ready to close.  | MX opening voltage release is permanently powered. | As there is an opening order, determine the origin of the order. The order must be canceled before the circuit breaker can be closed. |
| | MN undervoltage release is not powered due to an opening order. | As there is an opening order, determine the origin of the order. The order must be canceled before the circuit breaker can be closed. |
| | MN undervoltage release is not powered due to insufficient voltage power supply. | Check the voltage and the MN supply circuit ($V > 0.85 U_n$). If the problem persists, replace the MN undervoltage release. |
| – | XF closing voltage release is continuously supplied, but circuit breaker was not ready-to-close when the closing order was sent (XF closing voltage release is not wired in series with PF ready-to-close contact). | <ul style="list-style-type: none"> Remove the power supply to the XF closing voltage release. Only if the circuit breaker is ready-to-close, send the closing order again via the XF closing voltage release. |

Circuit Breaker Cannot be Opened by Using an External Pushbutton/Electrical Order

| Probable causes | Solutions |
|--|---|
| Opening order is not executed by the MN undervoltage release. | Drop in voltage insufficient or residual voltage ($V > 0.35 U_n$) across the terminals of the MN undervoltage release. If the problem persists, replace the MN undervoltage release. |
| Opening order is not executed by the MX opening voltage release. | Check the voltage and the MX supply circuit (0.7–1.1 Un). If the problem persists, replace the MX opening voltage release. |

Additional Checks

If the troubleshooting actions described above do not work, refer to the troubleshooting information for Troubleshooting: Mechanical Control Operations, page 105.

Schneider Electric
35 rue Joseph Monier
92500 Rueil Malmaison
France

+ 33 (0) 1 41 29 70 00

www.se.com

As standards, specifications, and design change from time to time, please ask for confirmation of the information given in this publication.

© 2024 – Schneider Electric. All rights reserved.

DOCA0297EN-02