

Harmony PSA6

Hardware Guide

EIO0000005603.01

02/2026

Legal Information

The information provided in this document contains general descriptions, technical characteristics and/or recommendations related to products/solutions.

This document is not intended as a substitute for a detailed study or operational and site-specific development or schematic plan. It is not to be used for determining suitability or reliability of the products/solutions for specific user applications. It is the duty of any such user to perform or have any professional expert of its choice (integrator, specifier or the like) perform the appropriate and comprehensive risk analysis, evaluation and testing of the products/solutions with respect to the relevant specific application or use thereof.

The Schneider Electric brand and any trademarks of Schneider Electric SE and its subsidiaries referred to in this document are the property of Schneider Electric SE or its subsidiaries. All other brands may be trademarks of their respective owner.

This document and its content are protected under applicable copyright laws and provided for informative use only. No part of this document may be reproduced or transmitted in any form or by any means (electronic, mechanical, photocopying, recording, or otherwise), for any purpose, without the prior written permission of Schneider Electric.

Schneider Electric does not grant any right or license for commercial use of the document or its content, except for a non-exclusive and personal license to consult it on an "as is" basis.

Schneider Electric reserves the right to make changes or updates with respect to or in the content of this document or the format thereof, at any time without notice.

To the extent permitted by applicable law, no responsibility or liability is assumed by Schneider Electric and its subsidiaries for any errors or omissions in the informational content of this document, as well as any non-intended use or misuse of the content thereof.

Table of Contents

Safety Information	5
About the Document	6
Overview	13
Part Numbers	13
Package Contents	13
Product Revision and QR Code	14
Certifications and Standards	14
Federal Communication Commission Radio Frequency Interference Statement - For USA	15
Accessories	17
Accessories	17
Maintenance Accessories	17
Parts Identification and Functions	18
Parts Identification	18
LED Indication	20
Specifications	21
General Specifications	21
Electrical Specifications	21
Environmental Specifications	22
Structural Specifications	22
Functional Specifications	25
Performance Specifications	25
Display Specifications	26
Touch Panel	26
Clock	26
Interface Specifications	27
Interfaces	27
Serial Interface	28
Dimensions	31
External Dimensions	31
External Dimensions (12-inch Wide)	31
External Dimensions (15-inch)	32
External Dimensions (15-inch Wide)	32
External Dimensions (19-inch Wide)	33
Installation Fastener Dimensions	33
Installation and Wiring	34
Precautions for Building into an End-use Product	34
Installation Requirements	34
Panel Cutout Dimensions	36
Installation Procedure	37
Removal Procedure	39
Wiring the Power Supply	41
DC Power Cord Preparation	41
How to connect the DC Power Cord	42
Power Supply Precautions	43
Grounding	44
M.2 SSD/M.2 Card Installation	45
Introduction	45

Opening the Maintenance Hatch	47
Installing M.2 SSD (SSD1)	47
Installing M.2 SSD (SSD2)	49
Installing M.2-E Card	51
USB Type A Cable Clamp	52
Attaching USB Cable Clamp	52
Removing USB Cable Clamp	54
Maintenance	56
Regular Cleaning	56
Periodic Check Points	56
Replacing the Battery	57
Replacing the Backlight	58
Cybersecurity	59
Cybersecurity Guideline	59
Security Seal	59
System Settings	61

Safety Information

Important Information

Read these instructions carefully, and look at the equipment to become familiar with the device before trying to install, operate, service, or maintain it. The following special messages may appear throughout this documentation or on the equipment to warn of potential hazards or to call attention to information that clarifies or simplifies a procedure.





The addition of this symbol to a "Danger" or "Warning" safety label indicates that an electrical hazard exists which will result in personal injury if the instructions are not followed.



This is the safety alert symbol. It is used to alert you to potential personal injury hazards. Obey all safety messages that follow this symbol to avoid possible injury or death.

 DANGER
DANGER indicates a hazardous situation which, if not avoided, will result in death or serious injury.

 WARNING
WARNING indicates a hazardous situation which, if not avoided, could result in death or serious injury.

 CAUTION
CAUTION indicates a hazardous situation which, if not avoided, could result in minor or moderate injury.

NOTICE
NOTICE is used to address practices not related to physical injury.

Please Note

Electrical equipment should be installed, operated, serviced, and maintained only by qualified personnel. No responsibility is assumed by Schneider Electric for any consequences arising out of the use of this material.

A qualified person is one who has skills and knowledge related to the construction and operation of electrical equipment and its installation, and has received safety training to recognize and avoid the hazards involved.

About the Document

Document Scope

This document describes the specifications, installation, operation, and maintenance of the Harmony PSA6, which is used in industrial or factory automation systems.

This document is intended for users who design systems, or install and maintain components.

Validity Note

This document is valid for Harmony PSA6.

The characteristics of the products described in this document are intended to match the characteristics that are available on www.se.com. As part of our corporate strategy for constant improvement, we may revise the content over time to enhance clarity and accuracy. If you see a difference between the characteristics in this document and the characteristics on www.se.com, consider www.se.com to contain the latest information.

Product Related Information

This product has been designed, developed and manufactured for use in industrial or factory automation systems.

- The product is not appropriate for use with aircraft control devices, medical life-support equipment, central trunk data transmission (communication) devices, or nuclear power control devices, due to inherent requirements for extremely high levels of safety and reliability.
- When using the product with transportation vehicles (trains, cars, and ships), disaster and crime prevention devices, safety equipment, or medical devices unrelated to life-support systems, use redundant and/or failsafe system designs to ensure reliability and safety.

If the equipment is used in a manner not specified by the manufacturer, the protection provided by the equipment may be impaired.

DANGER

HAZARD OF ELECTRIC SHOCK, EXPLOSION, OR ARC FLASH

- Remove all power from the device before removing any covers or elements of the system, and prior to installing or removing any accessories, hardware, or cables.
- Unplug the power cable from both this product and the power supply prior to installing or removing the product.
- Always use a properly rated voltage sensing device to confirm power is off where and when indicated.
- Replace and secure all covers or elements of the system before applying power to this product.
- Use only the specified voltage when operating this product. This product is designed to use 24 Vdc. Always check whether your device is DC powered before applying power.

Failure to follow these instructions will result in death or serious injury.

⚠ DANGER

POTENTIAL FOR EXPLOSION

- Do not use this product in hazardous environments.
- Do not connect or disconnect this product unless power has been switched off or the area is known to be non-hazardous.
- Do not attempt to install, operate, modify, maintain, service, or otherwise alter this product except as permitted in this manual.
- Confirm that the USB cable has been attached with the USB cable clamp before using the USB interface.

Failure to follow these instructions will result in death or serious injury.

Critical alarm indicators and system functions require independent and redundant protection hardware and/or mechanical interlocks.

Please design a safety circuit external to this product so that the entire system operates safely even if the external power supply or this product fails or malfunctions.

- Interlocks and other circuits designed to interrupt or prevent equipment operation (such as emergency stops, protective circuits, and opposing action circuits) and circuits that prevent machine damage, such as positioning mechanisms, should be constructed external to the product.
- The product stops operation when it detects an abnormality such as a watchdog timer error. If an error occurs in the input/output control area, which cannot be monitored, it may lead to unexpected input/output behavior. Therefore, it is important to configure an external fail-safe circuit or mechanism.
- Problems with the relay or transistor in the output unit may cause the output to remain either in the ON or OFF state. Install an external monitoring circuit for output signals that may cause a serious accident.

Design the circuit so that power is supplied to the external device or load control power supply connected to this product before it starts.

When you cycle power, wait at least 10 seconds after it has been turned off. If this product is restarted too quickly, it may not operate correctly.

Do not create any switches on the touch panel that may cause personal injury, property damage, or compromise the safety of the equipment. Design the system so that controls for important operations are managed by devices other than this product, or by independent hardware switches.

In the event the screen cannot be properly read, for example, if the backlight is not functioning, it may be difficult or impossible to identify a function. Functions that may present a hazard if not immediately executed, such as a fuel shut-off, must be provided independently of this product.

⚠ WARNING

LOSS OF CONTROL

- The designer of any control scheme must consider the potential failure modes of control paths and, for certain critical control functions, provide a means to achieve a safe state during and after a path failure. Examples of critical control functions are emergency stop and overtravel stop, power outage and restart.
- Separate or redundant control paths must be provided for critical control functions.
- System control paths may include communication links. Consideration must be given to the implications of unanticipated transmission delays or failures of the link.
- Observe all accident prevention regulations and local safety guidelines.
- Each implementation of this product must be individually and thoroughly tested for proper operation before being placed into service.
- The machine control system design must take into account the possibility of the backlight no longer functioning and the operator being unable to control the machine, or making errors in the control of the machine.

Failure to follow these instructions can result in death, serious injury, or equipment damage.

For additional information, refer to NEMA ICS 1.1 (latest edition), "Safety Guidelines for the Application, Installation, and Maintenance of Solid State Control" and to NEMA ICS 7.1 (latest edition), "Safety Standards for Construction and Guide for Selection, Installation and Operation of Adjustable-Speed Drive Systems" or their equivalent governing your particular location.

NOTE: This product is a highly configurable device and is not based on a real-time operating system. Changes to the software and settings of the following must be considered new implementations as discussed in the previous warning messages. Examples of such changes include:

- System BIOS
- Operating System
- Installed hardware
- Installed software

⚠ WARNING

UNINTENDED EQUIPMENT OPERATION

- The application of this product requires expertise in the design and programming of control systems. Only persons with such expertise should be allowed to program, install, alter, and apply this product.
- Do not use this product as the only means of control for critical system functions such as motor start/stop or power control.
- Do not use this equipment as the only notification device for critical alarms, such as device overheating or overcurrent.
- Use only the software provided with this product. If you use other software, please confirm the operation and safety before use.
- Follow all applicable safety standard and local regulations and directives.

Failure to follow these instructions can result in death, serious injury, or equipment damage.

The following characteristics are specific to the LCD panel and are considered normal behavior:

- LCD screen may show unevenness in the brightness of certain images or may appear different when seen from outside the specified viewing angle. Extended shadows, or crosstalk may also appear on the sides of screen images.

- LCD screen pixels may contain black and white colored spots and color display may seem to have changed.
- When experiencing vibrations within a certain frequency range and vibration acceleration is above what is acceptable, the LCD screen may partially turn white. Once the vibration condition ends, the whitening of the screen is resolved.
- When the same image is displayed on the screen for a long period, an afterimage may appear when the image is changed.
- The panel brightness may decrease when used for a long time in an environment continuously filled with inert gas. To prevent deterioration of panel brightness, regularly ventilate the panel. For more information, please contact customer support.
www.se.com/support

▲ WARNING

SERIOUS EYE AND SKIN INJURY

The liquid in the LCD panel contains an irritant:

- Avoid direct skin contact with the liquid.
- Wear gloves when you handle a broken or leaking unit.
- Do not use sharp objects or tools in the vicinity of the LCD panel.
- Handle the LCD panel carefully to prevent puncture, bursting, or cracking of the panel material.
- If the panel is damaged and any liquid comes in contact with your skin, immediately rinse the area with running water for at least 15 minutes. If the liquid gets in your eyes, immediately rinse your eyes with running water for at least 15 minutes and consult a doctor.

Failure to follow these instructions can result in death, serious injury, or equipment damage.

NOTICE

REDUCTION OF SERVICE LIFE OF PANEL

Change the screen image periodically and try not to display the same image for a long period of time.

Failure to follow these instructions can result in equipment damage.

Precautions on using models with projected capacitive touch panel

Models with a projected capacitive touch panel may operate abnormally when the display surface is wet.

▲ WARNING

LOSS OF CONTROL

- Do not touch the touch panel area during operating system startup.
- Do not operate when the touch panel surface is wet.
- If the touch panel surface is wet, remove any excess water with a soft cloth before operation.

Failure to follow these instructions can result in death, serious injury, or equipment damage.

NOTE: This product has an automatic background calibration function. This function runs for approximately 10 seconds after the power is turned on. While the system is starting up, do not touch the touch panel area.

NOTICE

EQUIPMENT DAMAGE

- Do not press on the display of this product with excessive force or with a hard object.
- Do not press on the touch panel with a pointed object, such as the tip of a mechanical pencil or a screwdriver.
- Handle this product carefully to prevent puncture, bursting, or cracking of the panel material.

Failure to follow these instructions can result in equipment damage.

Compared to conventional analog resistive film, projected capacitive touch panels have higher transmittance and lighter touch operation, as well as supporting multi-touch. As it is able to detect weak changes in capacitance, projected capacitive touch panels are susceptible to environmental noise.

While our products have been optimized for industrial environmental noise and conform to CE marking, our products cannot support all environmental noise.

Please consider the following in the installation environment to avoid touch malfunction.

Example:

To reduce the noise voltage of the enclosure of the equipment housing this product:

- Implement noise countermeasures in the equipment. For example, install a noise filter on the inverter, servo amplifier, or other equipment. Refer to the manufacturer's instruction manual.
- Attach a ground wire noise filter to the FG connection of equipment.
- Connect the enclosure for the equipment to the building. For example, connect to the concrete or steel reinforcement parts of the building.

NOTE: If there is a lot of environmental noise, because the noise filter for the touch panel controller has to run, touch response may become slow.

General Cybersecurity Information

In recent years, the growing number of networked machines and production plants has seen a corresponding increase in the potential for cyber threats, such as unauthorized access, data breaches, and operational disruptions. You must, therefore, consider all possible cybersecurity measures to help protect assets and systems against such threats.

To help keep your Schneider Electric products secure and protected, it is in your best interest to implement the cybersecurity best practices as described in the [Cybersecurity Best Practices](#) document.

Schneider Electric provides additional information and assistance:

- [Subscribe to the Schneider Electric security newsletter.](#)
- [Visit the Cybersecurity Support Portal web page to:](#)
 - [Find Security Notifications.](#)
 - [Report vulnerabilities and incidents.](#)
- [Visit the Schneider Electric Cybersecurity and Data Protection Posture web page to:](#)
 - [Access the cybersecurity posture.](#)
 - [Learn more about cybersecurity in the cybersecurity academy.](#)
 - [Explore the cybersecurity services from Schneider Electric.](#)

Product Related Cybersecurity Information

Refer to [Cybersecurity](#), page 59.

Environmental Data

For product compliance and environmental information, refer to the [Schneider Electric Environmental Data Program](#).

Available Languages of the Document

The document is available in these languages:

- [English \(EIO0000005603\)](#)
- [French \(EIO0000005604\)](#)
- [German \(EIO0000005605\)](#)
- [Spanish \(EIO0000005606\)](#)
- [Italian \(EIO0000005607\)](#)
- [Chinese \(EIO0000005608\)](#)

Related Documents

Title of documentation	Reference number
Cybersecurity Best Practices	Refer to General Cybersecurity Information, page 11.
HMI/IPC Cybersecurity Guide	EIO0000004948 (ENG)
Harmony PSA6 Windows System Setting User Guide	EIO0000005686 (ENG)

You can download the manuals related to this product, such as the software manual, from the Schneider Electric download center (www.se.com/ww/en/download).

Information on Non-Inclusive or Insensitive Terminology

As a responsible, inclusive company, Schneider Electric is constantly updating its communications and products that contain non-inclusive or insensitive terminology. However, despite these efforts, our content may still contain terms that are deemed inappropriate by some customers.

Trademarks

Microsoft® and Windows® are registered trademarks of Microsoft Corporation in the United States and/or other countries.

Intel®, Core™ and Atom® are registered trademark of Intel Corporation.

QR Code is a registered trademark of DENSO WAVE INCORPORATED in Japan and other countries.

Product names used in this manual may be the registered trademarks owned by the respective proprietors.

Overview

What's in This Chapter

Part Numbers..... 13
 Package Contents 13
 Product Revision and QR Code 14
 Certifications and Standards 14
 Federal Communication Commission Radio Frequency Interference
 Statement - For USA 15

Part Numbers

Part Number List

Series	Display size	Part number
Harmony PSA6	12-inch wide	HMIPSA6AED18W11
	15-inch	HMIPSA6A7D18W11
	15-inch wide	HMIPSA6AFD18W11 HMIPSA65FD18W11 HMIPSA65FD2AW11
	19-inch wide	HMIPSA65GD18W11 HMIPSA65GD2AW11

NOTE: All part numbers may be followed by any letter or number.

Part Number Configuration

The following describes the configuration of model numbers.

Digit	Category	Number	Description
1-7	(Prefix)	HMIPSA6	
8	CPU	A	Atom
		5	Core i5
9	Size	7	15-inch
		E	12-inch wide
		F	15-inch wide
		G	19-inch wide
10	Power	D	24 Vdc
11	Main storage	1	M.2 SATA SSD 128 GB
		2	M.2 NVMe SSD 256 GB
12	Memory	8	DIMM 8 GB
		A	DIMM 16 GB
13-15	Operating System	W11	Windows 11 IoT Enterprise 2024 LTSC (64 bit)

Package Contents

Verify all items listed here are present in your package.

If you find anything damaged or missing, please contact customer support immediately.

⚠ WARNING

UNINTENDED EQUIPMENT OPERATION

Do not use damaged products or accessories.

Failure to follow these instructions can result in death, serious injury, or equipment damage.

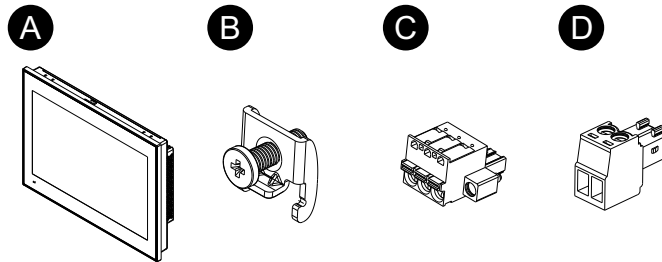

- A. HMIPSA6 model x 1
- B. Installation fasteners*1 (to install on a panel):
 - 4 pieces (for 12-inch wide model)
 - 8 pieces (for 15-inch, 15-inch wide and 19-inch wide)
- C. DC power connector x 1
- D. Connector to extend the power button x 1, refer to *Parts Identification*, page 18.

*1 There is no installation fastener prepared as a maintenance accessory. Please do not lose the fasteners included in your package.

Product Revision and QR Code

You can identify the product version (PV) and the software version (SV) from the product label.

You can also check the contents of this manual by using the QR code on the product label. Confirm the location of the QR code below and refer to the manual.

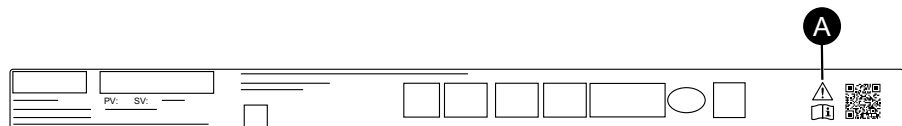

- A. This mark indicates that you can refer to wiring requirements in this manual by using the QR code. Refer to *Wiring the Power Supply*, page 41.

Certifications and Standards

The certifications and standards listed below may include those that are not yet acquired. Please check the product marking and the following URL for the latest acquisition status.

www.se.com/ww/en/download

Agency Certifications

- Underwriters Laboratories LLC., UL 61010-1 and CSA C22.2 No. 61010-1-12; UL 61010-2-201 and CSA C22.2 No. 61010-2-201; for Industrial Control Equipment used in Ordinary Locations

Compliance Standards

Europe:

CE/UKCA

- Directive 2014/30/EU (EMC)

Australia:

- RCM

Hazardous Substances

This product is designed to be compliant with the following environmental regulations, even if the product may not fall directly in the scope of the regulation:

- RoHS, Directive 2011/65/EU and 2015/863/EU
- RoHS China, Standard GB/T 26572
- REACH regulation EC 1907/2006

End of Life (WEEE)

The product contains electronic boards. It must be disposed of in specific treatment channels. The product contains cells and/or storage batteries which must be collected and processed separately when they have run out and at the end of product life (Directive 2012/19/EU).

Refer to [Maintenance](#), page 56 when extracting cells and batteries from the product. These batteries do not contain a weight percentage of heavy metals over the threshold notified by European Battery Regulation 2023/1542.

Federal Communication Commission Radio Frequency Interference Statement - For USA

FCC Radio Interference Information

This product has been tested and found to comply with the Federal Communications Commission (FCC) limits for a Class A digital device, pursuant to Part 15 of the FCC Rules. These limits are designed to provide reasonable protection against harmful interference in a commercial, industrial or business environment. This product generates, uses, and can radiate radio frequency energy and, if not installed and used in accordance with the instructions, may cause or be subject to interference with radio communications. To minimize the possibility of electromagnetic interference in your application, observe the following two rules:

- Install and operate this product in such a manner that it does not radiate sufficient electromagnetic energy to cause interference in nearby devices.
- Install and test this product to ensure that the electromagnetic energy generated by nearby devices does not interfere with the operation of this product.

⚠ WARNING**ELECTROMAGNETIC / RADIO INTERFERENCE, UNINTENDED EQUIPMENT OPERATION**

Check for electromagnetic and radio interference. If interference is detected, take the following actions.

- Increase the distance between this product and the interfering equipment.
- Reorient this product and the interfering equipment.
- Reroute power and communication lines to this product and the interfering equipment.
- Connect this product and the interfering equipment to different power supplies.
- Always use shielded cables when connecting this product to a peripheral device or another computer.

Failure to follow these instructions can result in death, serious injury, or equipment damage.

Changes or modifications not expressly approved by the party responsible for compliance could void the user's authority to operate this product.

Accessories

What's in This Chapter

Accessories 17
 Maintenance Accessories 17

Accessories

This section introduces optional items that are sold separately.

Products may change or be discontinued without notice. Please check our website for the latest information.

www.se.com/docs

Product name	Product number
Storage	
M.2 SATA SSD 128 GB (Type 2280, Key B+M)	HMIYPSA6M2128L
M.2 SATA SSD 512 GB (Type 2280, Key B+M)	HMIYPSA6M2512L
M.2 NVMe SSD 256 GB (Type 2280, Key M)*2	HMIYPSA6NVM256
Cable	
DP-DVI Cable (5 m)*1	HMIYFPCBDPDV5M
USB/Audio Conversion Cable	HMIYP6CVUSAU
Others	
Trellix license	HMIYP6LSMCA
USB Clamp Type A (5 pieces/set)	HMIZCCLUSA

*1 This is a passive cable.

*2 Supports the SSD1 slot on the i5 models only.

Maintenance Accessories

This section lists replacement parts.

Product name	Product number
Power connector (DC) (5 pieces/set)	HMIZCCNDC1

Parts Identification and Functions

What's in This Chapter

Parts Identification..... 18
 LED Indication 20

Parts Identification

NOTE: The figures below show the 12-inch wide model.

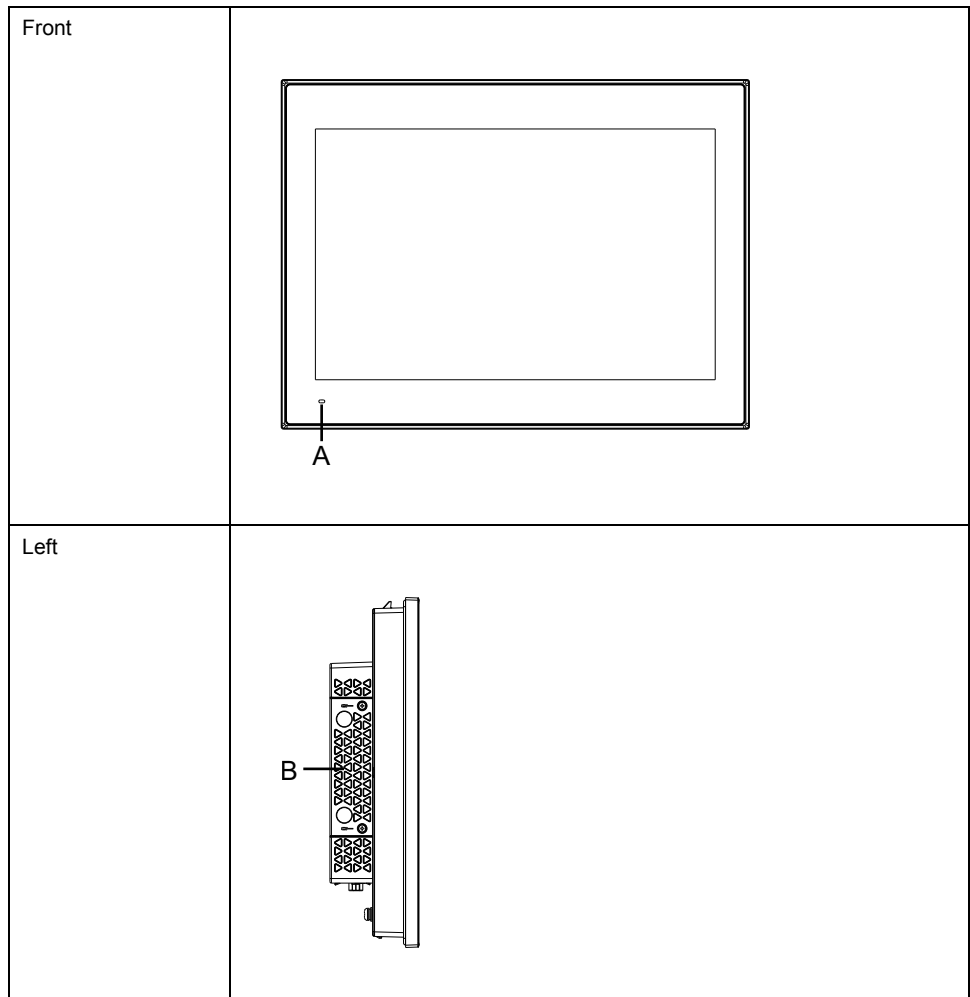

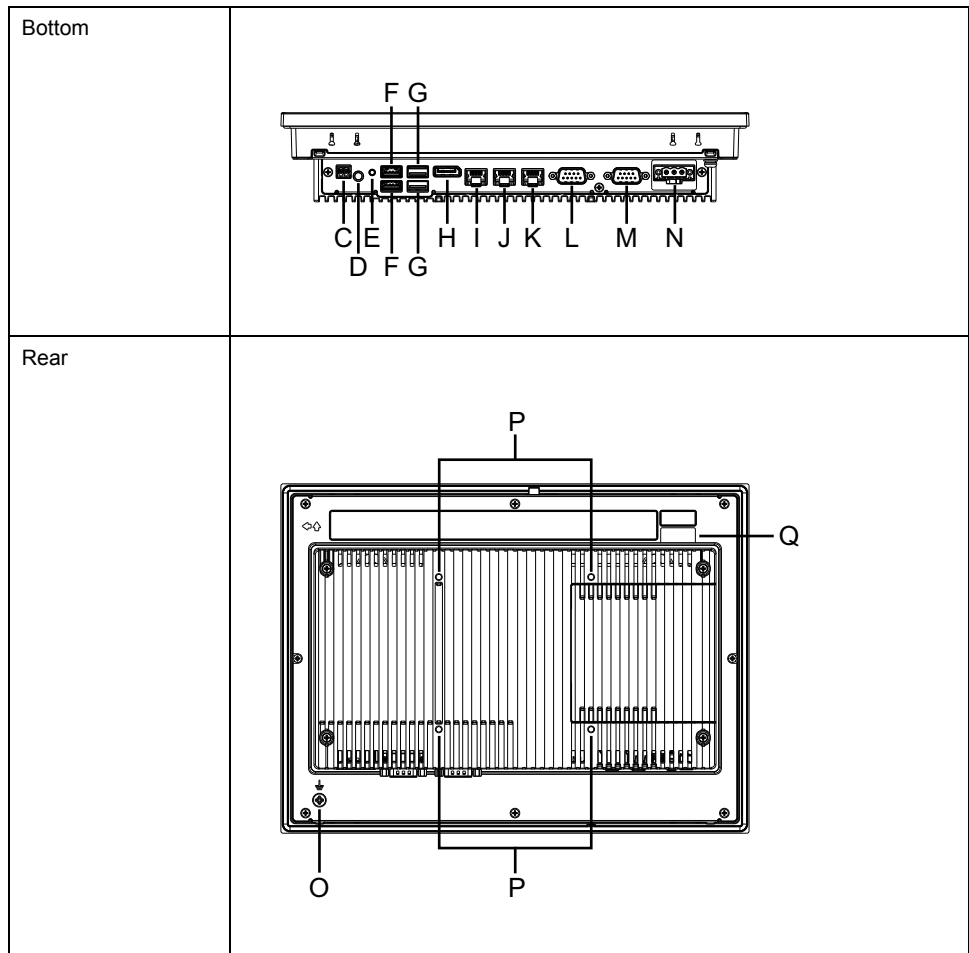

- | | |
|---|---|
| A. Status LED | J. Ethernet interface (ETH2) |
| B. Maintenance hatch | K. Ethernet interface (ETH1) |
| C. Remote power button connector (EXT) ^{*1*} | L. Serial interface (RS-422/485, non-isolated) (COM2) |
| D. Power button ^{*2} | M. Serial interface (RS-232C, non-isolated) (COM1) |
| E. Reset button (RESET) | N. DC power connector |
| F. USB 3.1 Gen1 (Type A) interface | O. FG terminal (⏏) |
| G. USB 2.0 (Type A) interface | P. VESA mount screw hole ^{*3} |
| H. DisplayPort (DP++) | Q. Security seal ^{*4} |
| I. Ethernet interface (ETH3) | |

*1 This is a connector for use to extend the power button. Use the connector included in your package and connect to an albeit contact (normally open).

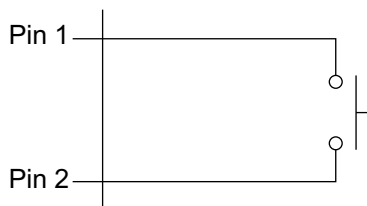

*2 The power button in Windows Power Options is set to **Shut down** by default. The following options are available for the power button. Select an option suitable for your usage environment.

- **Do nothing**
- **Sleep**

- **Hibernate**
- **Shut down** (default)
- **Turn off the display**

*3 This product can be mounted to commercially available monitor arms that comply with the VESA standard (100 x 100 mm). Use four M4 screws (valid screw depth: 7.4 mm [0.29 in]). The necessary torque is 1.0 N•m (8.9 lb-in). VESA mounting is not UL certified.

*4 Do not remove the security seal. For details, refer to *Security Seal*, page 59.

LED Indication

Status LED

Color	State	Description
Green	ON	S0 (in operation)
	Flashing	Screen is turned off.
Orange	ON	S3
	Flashing	System is starting up.
Red	ON	S4, S4 (hybrid shutdown)*1, S5
-	OFF	G3 (power is off)

*1 S4 (hybrid shutdown) is S5 when Windows® fast startup is enabled.

Wake-up Events

The following is a table showing the statuses that are set to the normal startup (S0) state when each action is executed.

ACPI state	Power state	Power up	Power button is ON	Wake on LAN	Touch input	USB equipment*1
S3	Sleep	-	✓	✓	✓	✓
S4	Hibernate	-	✓	✓	-	-
S4 (hybrid shutdown)	Hibernate	-	✓	-	-	-
S5	Soft off	-	✓	✓	-	-
G3	Mechanical off	✓	-	-	-	-

*1 Limited to USB devices that support the remote wake-up function.

NOTE: If you turn on the power when G3 is set, it directly enters state S0.

Specifications

What's in This Chapter

General Specifications.....21
 Functional Specifications25
 Interface Specifications.....27

General Specifications

Electrical Specifications

Rated input voltage		24 Vdc
Input voltage limits		19.2...28.8 Vdc
Voltage dip/short interruption immunity		1 ms or less at 20.4 Vdc
Power consumption*1*2	Max	12" wide (Atom): 50 W 15" (Atom): 50 W 15" wide (Atom): 55 W 15" wide (Core i5): 58 W 19" wide (Core i5): 60 W
	When power is not supplied to external devices	12" wide (Atom): 40 W 15" (Atom): 40 W 15" wide (Atom): 45 W 15" wide (Core i5): 50 W 19" wide (Core i5): 54 W
	When screen turns off (power is not supplied to external devices)	12" wide (Atom): 30 W 15" (Atom): 30 W 15" wide (Atom): 30 W 15" wide (Core i5): 35 W 19" wide (Core i5): 35 W
In-rush current		30 A or less
Dielectric strength		N/A (non-isolated)
Insulation resistance		N/A (non-isolated)

*1 The power loss is the same as the power consumption.

*2 When turbo boost is enabled, the power load may increase momentarily and the product may reboot. Use a power supply with at least an 80% output margin over the specified power consumption for this product. The same applies when using a circuit breaker. The use of instantaneous trip circuit breaker is not recommended. To avoid the power load, use with turbo boost disabled.

Environmental Specifications

Use and store this product in areas that conform to the specified conditions.

NOTE: When using any of the options for this product, check the specifications for special conditions or cautions that may apply to this product.

Physical environment	
Ambient air temperature	0...50 °C (32...122 °F) (with an airflow velocity of 0.6 m/s) 0...40 °C (32...104 °F) (with no airflow)
Storage temperature	-20...60 °C (-4...140 °F)
Ambient air and storage humidity	10...90% RH (non-condensing, wet bulb temperature 39 °C [102.2 °F] or less)
Dust	0.1 mg/m ³ (10 ⁻⁷ oz/ft ³) or less (non-conductive levels)
Pollution degree	For use in Pollution Degree 2 environment
Corrosive gases	Free of corrosive gases
Atmospheric pressure (operating altitude)	800...1,114 hPa (2,000 m [6,561 ft] or lower)
Mechanical environment	
Vibration resistance	IEC/EN 61131-2 compliant 5...9 Hz Single amplitude 3.5 mm (0.14 in) 9...150 Hz Fixed acceleration: 9.8 m/s ² X, Y, Z directions for 10 cycles (approximately 100 minutes)
Shock resistance	IEC/EN 61131-2 compliant 147 m/s ² , X, Y, Z directions for 3 times
Electrical environment	
Electrical fast transient/burst immunity	IEC 61000-4-4 2 kV: Power port 1 kV: Signal ports
Electrostatic discharge immunity	Contact discharge method: 6 kV Air discharge method: 8 kV (IEC/EN 61000-4-2 Level 3)

⚠ CAUTION

INOPERATIVE EQUIPMENT

- Do not operate or store the product where chemicals evaporate, or where chemicals are present in the air. Chemicals refer to the following: A) Corrosive chemicals: Acids, alkalines, liquids containing salt, B) Flammable chemicals: Organic solvents.
- Do not allow water, liquids, metal, and wiring fragments to enter the panel case.

Failure to follow these instructions can result in injury or equipment damage.

Structural Specifications

12-inch Wide Model

Grounding	Functional grounding: Grounding resistance of 100 Ω or less, 2 mm ² (AWG 14) or thicker wire, or your country's applicable standard (SG and FG are connected inside the product.)
Cooling method	Natural air circulation

Structure*1	<ul style="list-style-type: none"> • Front IP66, UL 50/50E, Type 4X (indoor use only) NOTE: On the front panel when properly installed in an enclosure. • Rear IP20
External dimensions (W x H x D)	307.4 x 229.4 x 58.8 mm (12.1 x 9.03 x 2.31 in)
Panel cutout dimensions (W x H)*2 *3	295 x 217 mm (11.61 x 8.54 in)
Weight	3.4 kg (7.5 lb) or less

15-inch Model

Grounding	Functional grounding: Grounding resistance of 100 Ω or less, 2 mm ² (AWG 14) or thicker wire, or your country's applicable standard (SG and FG are connected inside the product.)
Cooling method	Natural air circulation
Structure*1	<ul style="list-style-type: none"> • Front IP66, UL 50/50E, Type 4X (indoor use only) NOTE: On the front panel when properly installed in an enclosure. • Rear IP20
External dimensions (W x H x D)	362.4 x 294 x 58.8 mm (14.27 x 11.57 x 2.31 in)
Panel cutout dimensions (W x H)*2 *3	349.5 x 281.5 mm (13.76 x 11.08 in)
Weight	4.8 kg (10.58 lb) or less

15-inch Wide Model

Grounding	Functional grounding: Grounding resistance of 100 Ω or less, 2 mm ² (AWG 14) or thicker wire, or your country's applicable standard (SG and FG are connected inside the product.)
Cooling method	Natural air circulation
Structure*1	<ul style="list-style-type: none"> • Front IP66, UL 50/50E, Type 4X (indoor use only) NOTE: On the front panel when properly installed in an enclosure. • Rear IP20
External dimensions (W x H x D)	406.4 x 262.4 x 58.8 mm (16.0 x 10.33 x 2.31 in)
Panel cutout dimensions (W x H)*2 *3	394 x 250 mm (15.51 x 9.84 in)
Weight	4.9 kg (10.8 lb) or less

19-inch Wide Model

Grounding	Functional grounding: Grounding resistance of 100 Ω or less, 2 mm ² (AWG 14) or thicker wire, or your country's applicable standard (SG and FG are connected inside the product.)
Cooling method	Natural air circulation

Structure*1	<ul style="list-style-type: none"> • Front IP66, UL 50/50E, Type 4X (indoor use only) NOTE: On the front panel when properly installed in an enclosure. • Rear IP20
External dimensions (W x H x D)	461.9 x 291.9 x 58.8 mm (18.18 x 11.49 x 2.31 in)
Panel cutout dimensions (W x H)*2*3	449.5 x 279.5 mm (17.7 x 11.0 in)
Weight	6.2 kg (13.67 lb) or less

*1 The front of this product has been tested to comply with the specified standards when installed in a solid panel. However, it is not intended for use in all environments. In environments where the product is exposed to liquids (including jets and sprays) for extended periods, there is a risk that liquids may enter the product due to causes such as peeling of the protective sheet or damage to the front glass cover. In such environments, implement appropriate protective measures based on the specific conditions. Therefore, prior to installing this product, be sure to confirm the type of conditions that will be present in this product's operating environment.

*2 The dimensional tolerance for the width and height of the mounting hole is +1/-0 mm (+0.04/-0 in). All the corners have a radius of R3 mm (R0.12 in) or less.

*3 Even if the installation wall thickness is within the specified range, depending on the wall's material, size, and installation location of this product and other devices, the installation wall could warp. To prevent warping, the installation surface may need to be strengthened.

NOTICE

EQUIPMENT DAMAGE

- Ensure this product is not in permanent and direct contact with oils.
- Do not press on the display of this product with excessive force or with a hard object.
- Do not press on the touch panel with a pointed object, such as the tip of a mechanical pencil or a screwdriver.

Failure to follow these instructions can result in equipment damage.

NOTICE

EQUIPMENT DAMAGE

Do not expose the product to direct sunlight.

Failure to follow these instructions can result in equipment damage.

NOTICE

STORAGE AND OPERATION OUTSIDE OF SPECIFICATIONS

- Store this product in areas where temperatures are within the product's specifications.
- Do not restrict or block the product's ventilation slots.

Failure to follow these instructions can result in equipment damage.

Functional Specifications

Performance Specifications

CPU	Intel Atom® Processor X Series, X7425E	13th Generation Intel® Core™ i5 Processors, i5-1345UE
Base frequency	1.50 GHz	1.40 GHz
Max turbo boost frequency*1	3.40 GHz	P-Core: 4.60 GHz E-Core: 3.40 GHz
L2 cache	6 MB	12 MB
Core number	4	P-Core: 2 E-Core: 8
Thread number	4	12
Main memory*2	Dual channel DDR5, up to 4,800 MHz (without ECC) 262-pin DDR5 SO-DIMM socket x 1 (up to 16 GB/socket) In-Band ECC function supported*3	Dual channel DDR5, up to 5,200 MHz (without ECC) 262-pin DDR5 SO-DIMM socket x 2 (up to 48 GB/socket, up to 96 GB for 2 sockets) In-Band ECC function not supported
Video memory	Shared with main memory (UMA) Maximum allocation size: Automatic allocation of up to half the installed main memory	
Main storage slot (SSD1)	M.2 SATA SSD 3.0 x 1, M.2 Key M, Type 2280 (default) or 2242 SATA speed: 6 Gb/s, 3 Gb/s, 1.5 Gb/s	M.2 SATA SSD 3.0/PCIe x 4 (auto switchable) x 1, M.2 Key M, Type 2280 (default) or 2242 SATA speed: 6 Gb/s, 3 Gb/s, 1.5 Gb/s PCIe link speed: 8 Gb/s, 5 Gb/s, 2.5 Gb/s
Storage slot (SSD2)	M.2 SATA SSD 3.0/PCIe (auto switchable) x 1, USB 2.0, M.2 Key B, Type 2280, 2252, 2242 SATA speed: 6 Gb/s, 3 Gb/s, 1.5 Gb/s	
Expansion slot (M.2-E)	M.2 PCIe/USB 2.0 card x 1, M.2 Key E, Type 2230	
Graphics accelerator	Intel® UHD Graphics	Intel® Iris® Xe Graphics eligible
Security chip	TPM 2.0	
BIOS	UEFI BIOS	
Operating system	Windows® 11 IoT Enterprise 2024 LTSC (64 bit)	
Buzzer	Yes	

*1 The CPU installed in this product is equipped with Intel® Turbo Boost Technology. The default setting is **Enabled**.

*2 The memory cannot be replaced, changed or expanded.

*3 For the setting of In-Band ECC, refer to Harmony PSA6 Windows System Setting User Guide.

Display Specifications

15-inch

	15-inch
Display type	TFT Color LCD
Display size	15"
Resolution	1,024 x 768 pixels (XGA)
Effective display area (W x H)	304.1 x 228.1 mm (11.97 x 8.98 in)
Display colors	16 million colors
Backlight	White LED (not user replaceable. Please contact customer support.)
Backlight service life	70,000 hours or more (continuous operation at 25 °C [77 °F] before backlight brightness decreases to 50%)
Brightness control	0...100 (adjusted with touch panel or software)

12-inch Wide, 15-inch Wide, 19-inch Wide

	12-inch wide	15-inch wide	19-inch wide
Display type	TFT Color LCD		
Display size	12.1"	15.6"	18.5"
Resolution	1,280 x 800 pixels (WXGA)	1,920 x 1,080 pixels (FHD)	
Effective display area (W x H)	261.12 x 163.2 mm (10.28 x 6.43 in)	344.16 x 193.59 mm (13.55 x 7.62 in)	408.96 x 230.04 mm (16.1 x 9.06 in)
Display colors	16 million colors		
Backlight	White LED (not user replaceable. Please contact customer support.)		
Backlight service life	30,000 hours or more (continuous operation at 25 °C [77 °F] before backlight brightness decreases to 50%)	50,000 hours or more (continuous operation at 25 °C [77 °F] before backlight brightness decreases to 50%)	
Brightness control	0...100 (adjusted with touch panel or software)		

Touch Panel

Touch panel type	Projected capacitive
Touch points	Multi-touch (two-point touch)
Touch panel service life	50 million times or more
Touch panel resolution	2,048 x 2,048

Clock

RTC accuracy	Deviation of ±60 seconds per month (at 25 °C [77 °F] and power is OFF).
Clock data backup	Lithium metal battery (primary battery, replaceable) Battery life: 5 years (approximate)

Variations in operating conditions and battery life can cause clock deviations from +300 and -300 seconds per month. If you use this product in a system where timing is critical, adjust the clock at regular intervals.

If the battery is depleted or removed, the clock data will be lost. To replace the battery, refer to [Replacing the Battery](#), page 57.

Interface Specifications

Interfaces

NOTE: Use only the SELV (Safety Extra-Low Voltage) circuit to connect all the interfaces.

Serial interface (COM1)	Asynchronous transmission	RS-232C (non-isolated) x 1
	Data length	7 or 8 bits
	Stop bit	1 or 2 bits
	Parity	None, odd or even
	Data transmission speed	2,400...115,200 bps
	Connector	D-Sub 9-pin (plug)
Serial interface (COM2)	Asynchronous transmission	RS-422/485 (non-isolated) x 1 (default: RS-485)
	Data length	7 or 8 bits
	Stop bit	1 or 2 bits
	Parity	None, odd or even
	Auto direction control	Enabled
	Data transmission speed	2,400...115,200 bps
	Connector	D-Sub 9-pin (plug)
USB 2.0 (Type A) interface*1	Connector	USB 2.0 (Type A) x 2
	Power supply voltage	5 Vdc ±5%
	Maximum current supplied	500 mA/port
	Maximum transmission distance	5 m (16.4 ft)
USB 3.1 Gen1 (Type A) interface*1	Connector	USB 3.1 Gen1 (Type A) x 2
	Power supply voltage	5 Vdc ±5%
	Maximum current supplied	900 mA/port
	Maximum transmission distance	3 m (9.84 ft)
Ethernet interface (ETH1, ETH2, ETH3)	Standard	10 BASE-T/ 100 BASE-TX/ 1000BASE-T, Wake-on-LAN (WOL) supported*2
	Connector	Modular jack (RJ-45) x 3
DisplayPort (DP++)	Version	V 1.2, dual mode (DP++) supported
	Resolution	Up to 4,096 x 2,304 pixels at 60 Hz

*1 The total maximum power output of all 4 USB Type A ports is 6 W.

*2 When the status is S4 (hybrid shutdown), Wake-on-LAN is unavailable.

Serial Interface

Precautions for Connecting Serial Interface

The serial interface is not isolated. The SG (signal ground) and FG (frame ground) terminals are connected inside this product. When the serial interface connector is D-Sub, connect the FG wire to the shell.

⚡⚠ DANGER

ELECTRIC SHOCK AND FIRE

- Verify that a ground loop is not created when you set up the system.
- When the SG and FG on the external device are not isolated, connect the product's SG to the SG on the external device.
- Connect the SG to a known reliable ground connection to reduce the risk of damaging the circuit.

Failure to follow these instructions will result in death or serious injury.

⚠ CAUTION

LOSS OF COMMUNICATION

- Do not put excessive stress on the communication ports of all connections.
- Securely attach communication cables to the panel wall or cabinet.
- Use a D-Sub 9 pin connector that has jack screws.

Failure to follow these instructions can result in injury or equipment damage.

NOTE: Use within the rated current.

RS-232C (COM1)

D-Sub 9 pin plug connector

Product side:

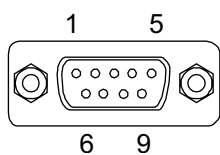

Pin No.	RS-232C		
	Signal name	Direction	Description
1	CD	Input	Carrier detect
2	RD (RXD)	Input	Receive data
3	SD (TXD)	Output	Send data
4	ER (DTR)	Output	Data terminal ready
5	SG	-	Signal ground (not isolated)
6	DR (DSR)	Input	Data set ready
7	RS (RTS)	Output	Request to send
8	CS (CTS)	Input	Send possible

Pin No.	RS-232C		
	Signal name	Direction	Description
9	CI (RI)	Input	Called status display
Shell	FG	-	Frame ground (common with SG)

Recommended jack screw is #4-40 (UNC).

RS-422/485 (COM2)

RS-422 and RS-485 can be switched in UEFI BIOS. For the setting, refer to RS-422/485 Port Setting, page 30.

(Default: RS-485)

RS-422

D-Sub 9 pin plug connector

Product side:

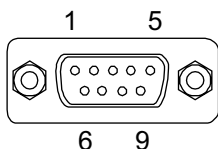

Pin No.	RS-422		
	Signal name	Direction	Description
1	TxD-	Output	Send data -
2	TxD+	Output	Send data +
3	RxD+	Input	Receive data +
4	RxD-	Input	Receive data -
5	SG	-	Signal ground (not isolated)
6	NC	-	No connection
7	NC	-	No connection
8	NC	-	No connection
9	NC	-	No connection
Shell	FG	-	Frame ground (common with SG)

Recommended jack screw is #4-40 (UNC).

RS-485

D-Sub 9 pin plug connector

Product side:

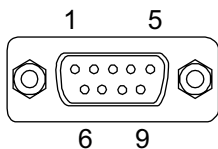

Pin No.	RS-425		
	Signal name	Direction	Description
1	Data-	Input/Output	Communication data -
2	Data+	Input/Output	Communication data +
3	NC	-	No connection
4	NC	-	No connection
5	SG	-	Signal ground (not isolated)
6	NC	-	No connection
7	NC	-	No connection
8	NC	-	No connection
9	NC	-	No connection
Shell	FG	-	Frame ground (common with SG)

Recommended jack screw is #4-40 (UNC).

RS-422/485 Port Setting

When switching RS-422 and RS-485, follow the procedure below.

1. Display the BIOS screen. Refer to Harmony PSA6 Windows System Setting User Guide.
2. Select **Advanced > NCT5525D Super IO Configuration > Serial Port 2 Configuration**.
3. Select **COM port 2 Mode**.
4. Select **RS-422** or **RS-485**.
5. Press the [F4] key.
6. Select **Yes** in the **Save & Exit Setup** dialog box.
7. The product is restarted.

Termination Resistor Setting

Termination resistor setting is necessary when using RS-422/485. The following describes how to set the termination resistor.

1. Display the BIOS screen. Refer to Harmony PSA6 Windows System Setting User Guide.
2. Select **Advanced > NCT5525D Super IO Configuration > Serial Port 2 Configuration**.
3. In **Termination resistors**, select **Enabled**.
4. Press the [F4] key.
5. Select **Yes** in the **Save & Exit Setup** dialog box.
6. The product is restarted.

Dimensions

What's in This Chapter

External Dimensions.....31
Installation Fastener Dimensions33

External Dimensions

External Dimensions (12-inch Wide)

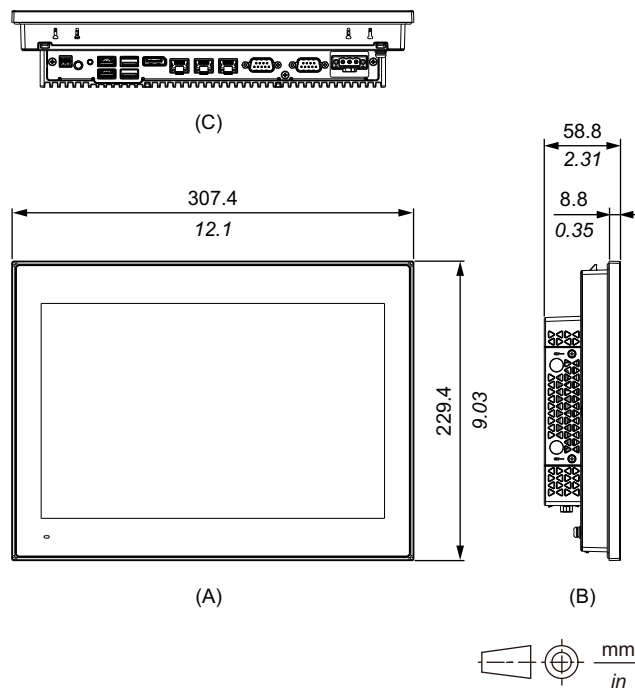

- A. Front
- B. Left
- C. Bottom

External Dimensions (15-inch)

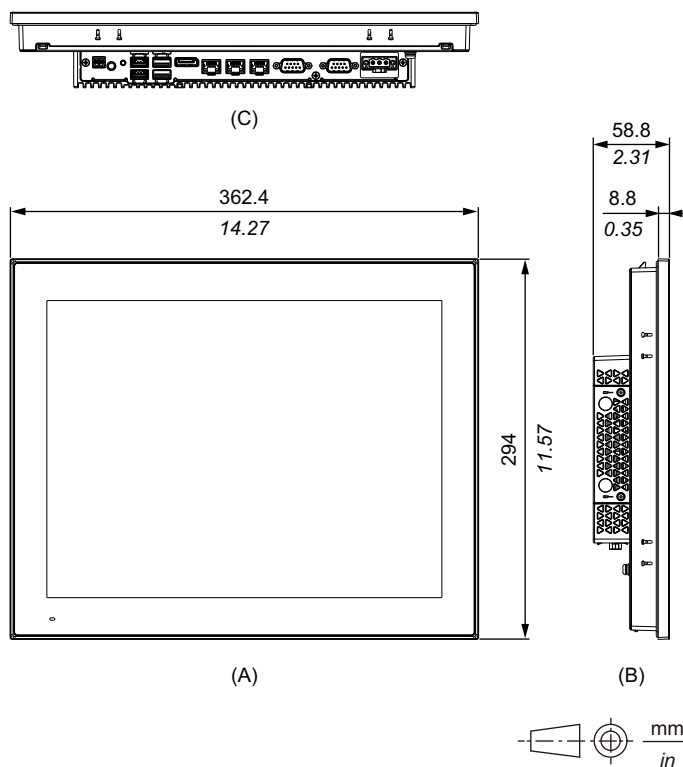

- A. Front
- B. Left
- C. Bottom

External Dimensions (15-inch Wide)

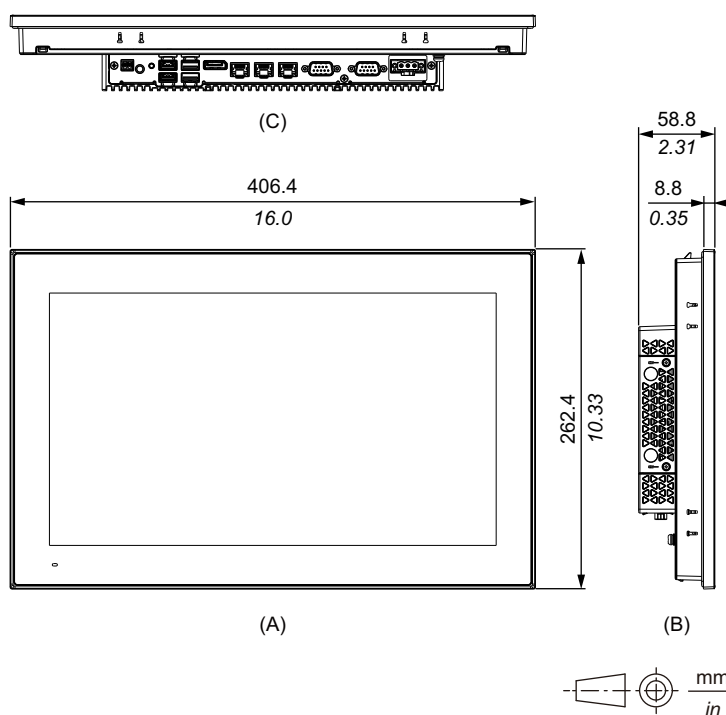

- A. Front
- B. Left
- C. Bottom

External Dimensions (19-inch Wide)

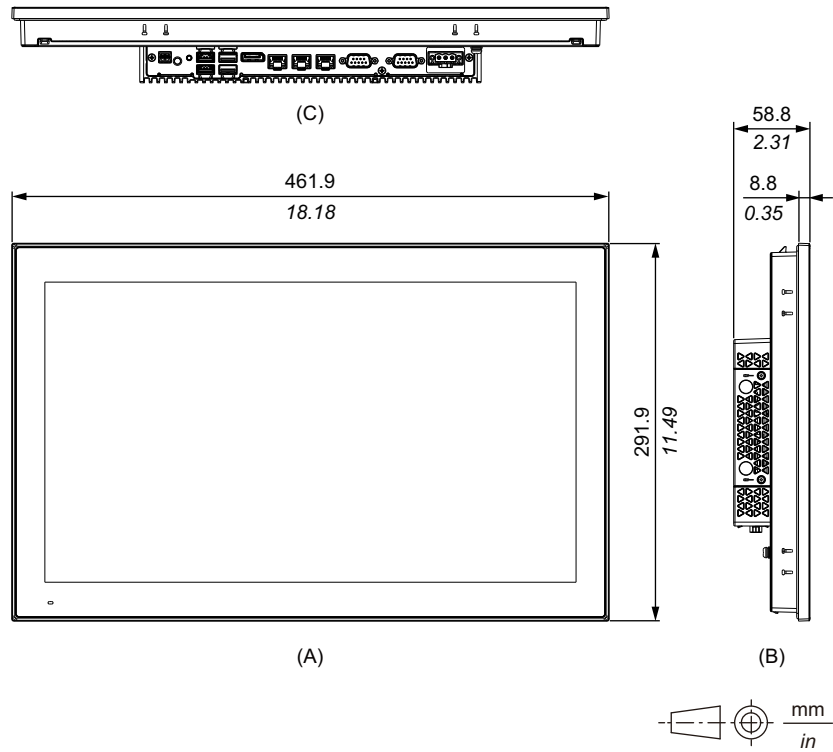

- A. Front
- B. Left
- C. Bottom

Installation Fastener Dimensions

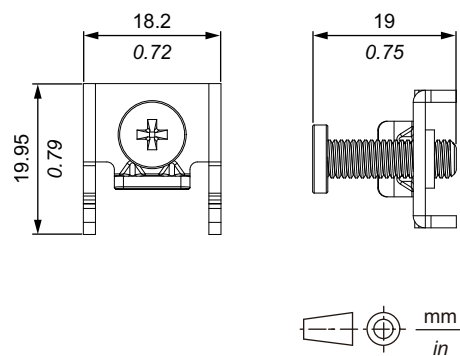

Installation and Wiring

What's in This Chapter

Precautions for Building into an End-use Product.....	34
Installation Requirements.....	34
Panel Cutout Dimensions.....	36
Installation Procedure.....	37
Removal Procedure.....	39
Wiring the Power Supply.....	41
M.2 SSD/M.2 Card Installation.....	45
USB Type A Cable Clamp.....	52

Precautions for Building into an End-use Product

This product is designed for use on flat surfaces of IP66, UL 50/50E or Type 4X (indoor use only) enclosure.

Be aware of the following when building this product into an end-use product:

- The rear face of this product is not approved as an enclosure. When building this product into an end-use product, be sure to use an enclosure that satisfies standards as the end-use product's overall enclosure.
- Install this product in an enclosure with mechanical rigidity.
- This product is an open type device and not designed for outdoor use. UL certification obtained is for indoor use only.
- Install and operate this product with its front panel facing outward.

NOTE: IP66 is not part of UL certification.

Installation Requirements

▲ CAUTION

RISK OF BURNING INJURY

Do not touch the bezel or rear chassis during operation.

Failure to follow these instructions can result in injury or equipment damage.

- Check that the installation wall or cabinet surface is flat, in good condition and has no jagged edges. Metal reinforcing strips may be attached to the inside of the wall, near the panel cutout, to increase its rigidity.
- Decide on the thickness of the enclosure wall, based on the level of strength required. Even if the installation wall thickness is within the specified range, depending on the wall's material, size, and installation location of this product and other devices, the installation wall could warp. To prevent warping, the installation surface may need to be strengthened. For the specified wall thickness range, refer to Panel Cutout Dimensions, page 36.

- Check that the ambient air temperature and the ambient humidity are within their specified ranges in *Environmental Specifications*, page 22. When installing this product in a cabinet or enclosure, the ambient air temperature is the cabinet's or enclosure's internal and external temperature.

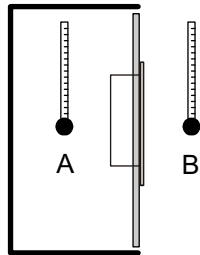

- A. Internal temperature
- B. External temperature

- Be sure that heat from surrounding equipment does not cause this product to exceed its standard operating temperature.
- When mounting this product in portrait orientation, ensure that the right side of this product faces up. In other words, the power connector should be at the top.

NOTE: Please make sure your applications support portrait orientation of the display.

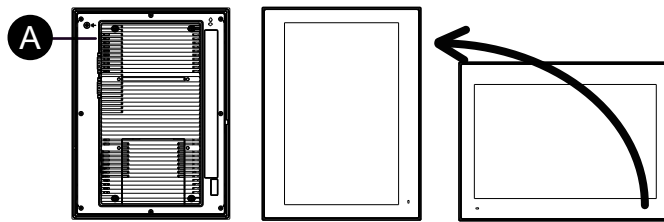

- A. Power connector

- When installing this product in a slanted position, the product face should not incline more than 30°.

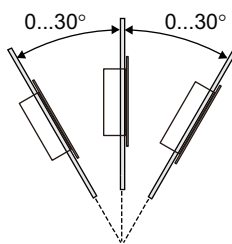

- For easier maintenance, operation and improved ventilation, install this product at least 100 mm (3.94 in) away from adjacent structures and other equipment as shown in the following illustration:

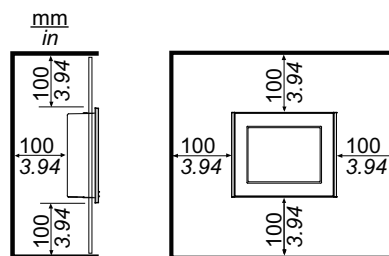

Pressure Differences

When applying and installing this product, it is important that steps are taken to eliminate any pressure difference between the inside and the outside of the enclosure in which this product is mounted. Higher pressure inside the enclosure can cause delamination of the front membrane of the display. Even a small pressure difference inside the enclosure will act on the large area of the membrane and can result in sufficient force to delaminate the membrane and thus cause failure of the touch capability. Pressure differences can often occur in applications where there are multiple fans and ventilators moving air at different rates in different rooms. Please follow these techniques to ensure that this product's function is not impacted by this mis-application:

1. Seal all conduit connections inside of the enclosure, especially those that lead to other rooms that may be at a different pressure.
2. Where applicable, install a small weep hole at the bottom of the enclosure to allow equalization of the internal and external pressure.

Panel Cutout Dimensions

Based on the panel cutout dimensions, open a mounting hole on the panel.

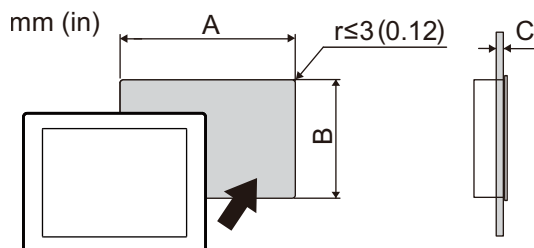

- A. Width
- B. Height
- C. Panel thickness

The dimensional tolerance for the width and height of the mounting hole is $+1/-0$ mm ($+0.04/-0$ in). All the corners have a radius of R3 mm (R0.12 in) or less.

Model Name		
A	B	C
12-inch wide		
295 mm (11.61 in)	217 mm (8.54 in)	1.6...5 mm (0.06...0.2 in)
15-inch		
349.5 mm (13.76 in)	281.5 mm (11.08 in)	1.6...5 mm (0.06...0.2 in)
15-inch wide		
394 mm (15.51 in)	250 mm (9.84 in)	1.6...5 mm (0.06...0.2 in)
19-inch wide		
449.5 mm (17.7 in)	279.5 mm (11.0 in)	1.6...5 mm (0.06...0.2 in)

Installation Procedure

⚠️⚠️ DANGER

HAZARD OF ELECTRIC SHOCK, EXPLOSION, OR ARC FLASH

- Remove all power from the device before removing any covers or elements of the system, and prior to installing or removing any accessories, hardware, or cables.
- Unplug the power cable from both this product and the power supply prior to installing or removing the product.
- Always use a properly rated voltage sensing device to confirm power is off where and when indicated.
- Replace and secure all covers or elements of the system before applying power to this product.
- Use only the specified voltage when operating this product. This product is designed to use 24 Vdc. Always check whether your device is DC powered before applying power.

Failure to follow these instructions will result in death or serious injury.

⚠️ CAUTION

RISK OF INJURY

- Hold this product in place after removing the screws.
- Use both hands.

Failure to follow these instructions can result in injury or equipment damage.

NOTICE

EQUIPMENT DAMAGE

Keep this product stabilized in the panel cutout while you are installing or removing the screw fasteners.

Failure to follow these instructions can result in equipment damage.

NOTICE

BROKEN ENCLOSURE

Do not exert more torque than the amount specified.

Failure to follow these instructions can result in equipment damage.

1. Based on the Panel Cutout Dimensions, page 36, open a mount-hole on the panel and attach the product to the panel from the front side.

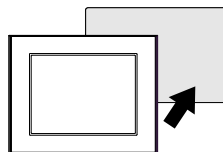

2. Confirm that the anti-drop lock on the top of the product is attached to the panel.

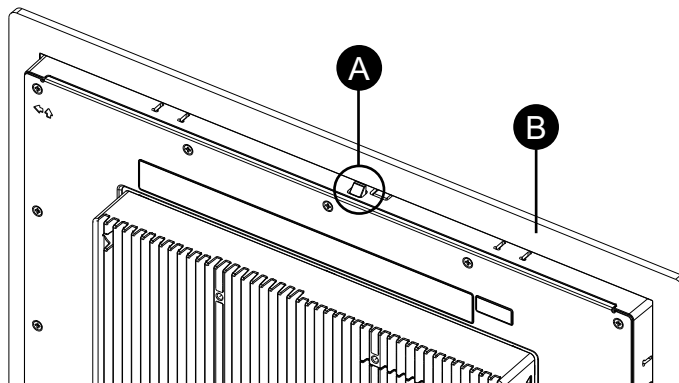

A. Anti-drop lock

B. Panel

3. Insert the installation fasteners into the bracket openings at the top, bottom, left and right, and use a screwdriver to tighten the screws little by little, alternating between diagonally-positioned screws.

NOTE: The necessary torque is 0.5 N•m (4.4 lb-in).

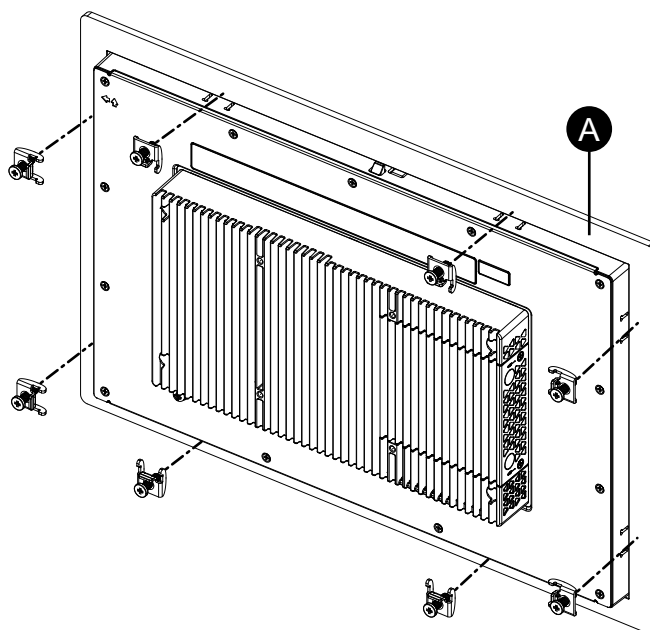

A. Panel

The number of installation fasteners for each model is as follows.

12-inch wide	Top - 2, Bottom - 2
15-inch, 15-inch wide, 19-inch wide	Top - 2, Bottom - 2, Left - 2, Right - 2

Removal Procedure

⚠️⚠️ DANGER

HAZARD OF ELECTRIC SHOCK, EXPLOSION, OR ARC FLASH

- Remove all power from the device before removing any covers or elements of the system, and prior to installing or removing any accessories, hardware, or cables.
- Unplug the power cable from both this product and the power supply prior to installing or removing the product.
- Always use a properly rated voltage sensing device to confirm power is off where and when indicated.
- Replace and secure all covers or elements of the system before applying power to this product.
- Use only the specified voltage when operating this product. This product is designed to use 24 Vdc. Always check whether your device is DC powered before applying power.

Failure to follow these instructions will result in death or serious injury.

⚠️ CAUTION

RISK OF INJURY

Do not drop this product when you remove it from the panel.

- Hold this product in place after removing the fasteners.
- Use both hands.
- While pushing on the anti-drop lock, be careful not to hurt your fingers.

Failure to follow these instructions can result in injury or equipment damage.

NOTICE

EQUIPMENT DAMAGE

Keep this product stabilized in the panel cutout while you are installing or removing the screw fasteners.

Failure to follow these instructions can result in equipment damage.

NOTICE

EQUIPMENT DAMAGE

Remove this product while pushing the anti-drop lock or by making sure the lock does not touch the panel.

Failure to follow these instructions can result in equipment damage.

1. Using a screwdriver, gradually loosen the screws for the fasteners (top, bottom, left, and right), alternating diagonally between screws until all screws are loose.

NOTE: For the number of installation fasteners on your model, refer to Number of Installation Fasteners in step 3 of Installation Procedure, page 37.

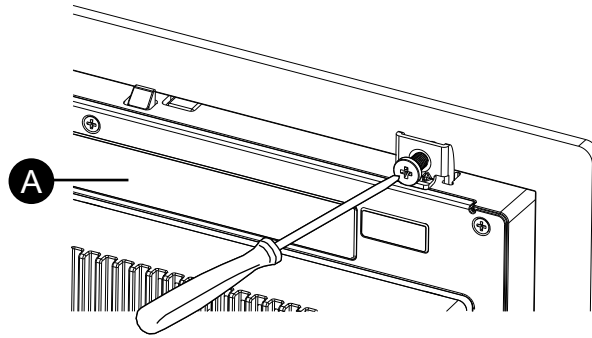

A. Rear side

2. While pushing on the anti-drop lock on the top of the product, slowly remove the product from the panel.

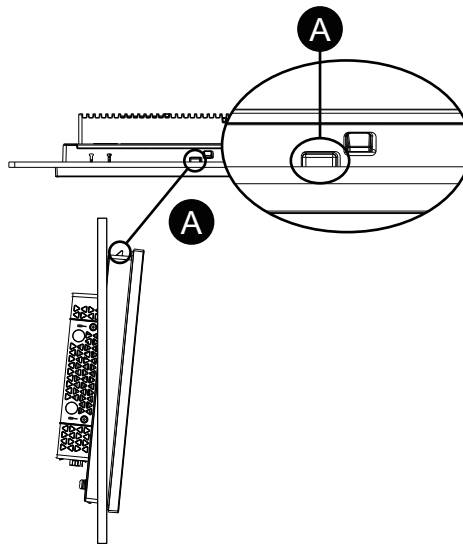

A. Anti-drop lock

Wiring the Power Supply

DC Power Cord Preparation

⚠️⚠️ DANGER

HAZARD OF ELECTRIC SHOCK, EXPLOSION, OR ARC FLASH

- Remove all power from the device before removing any covers or elements of the system, and prior to installing or removing any accessories, hardware, or cables.
- Remove power before wiring this product's power terminals.
- Always use a properly rated voltage sensing device to confirm power is off where and when indicated.
- Replace and secure all covers or elements of the system before applying power to this product.
- Use only the specified voltage when operating this product. This product is designed to use 24 Vdc. Always check whether your device is DC powered before applying power.
- Since this product is not equipped with a power switch, be sure to connect a power switch to the power supply.
- Be sure to ground this product's FG terminal.

Failure to follow these instructions will result in death or serious injury.

NOTE:

- The SG (signal ground) and FG (frame ground) terminals are connected internally in this product.
- When the FG terminal is connected, be sure the wire is grounded. Not grounding this product can result in excessive electromagnetic interference (EMI).
- Make sure the ground wire is either the same or heavier gauge than the power wires.
- Do not use aluminum wires in the power supply's power cord.
- If the ends of the individual wires are not twisted correctly, the wires may create a short circuit. When inserting a wire into the connector, hold down the opening button and insert the wire while the internal spring is depressed. Alternatively, you can crimp and insert either a pin terminal or ferrule terminal.
- The conductor type is solid or stranded wire.
- Use copper wire rated for 75 °C (167 °F) or higher.
- Use the SELV (Safety Extra-Low Voltage) circuit and LIM (Limited Energy) circuit for DC input.

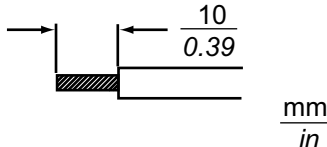
DC power cord	
Recommended cross section	0.75...3.5 mm ² (18...12 AWG)* ¹
Conductor type	Solid or stranded wire* ²
Conductor length	

*¹ Thick wires are recommended to minimize voltage drops in the wire.

*2 When using stranded wires, confirm the allowable current of the wire.

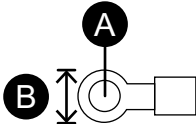
DC grounding wire	
Recommended cross section	2 mm ² or more (14 AWG or greater)
Ring terminal size*1	 <p>A. $\Phi 4.3$ mm (0.17 in) or more B. 7.2 mm (0.28 in) or less</p>

*1 To prevent a short circuit caused by loose screws, use a crimp-type terminal with an insulating sleeve.

How to connect the DC Power Cord

DC Power Connector: Spring Clamp Terminal Blocks

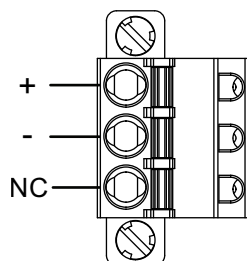

Connection	Wire
+	24 Vdc
-	0 Vdc
NC	No connection

1. Remove the screw on the FG terminal on the rear of the product, connect the grounding wire, and tighten the screw.

NOTE:

- The necessary torque is 1.5 N•m (13.3 lb-in).
- If the wire is not connected to the FG terminal properly, touch may not respond normally.

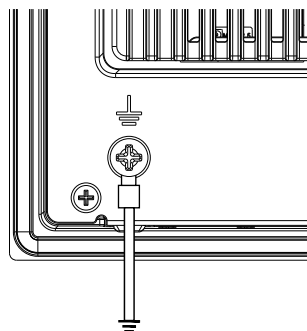

2. Confirm the power cord is not connected to the power supply.
3. Crimp a pin terminal properly to the end of each power cable wire.

4. Push the opening button with a small and flat screwdriver to open the desired pin hole.
5. Insert each power cord wire into its corresponding hole. Release the opening button to clamp the wire in place.

NOTE:

- When using stranded wire, do not short with neighboring wires.
- When connecting with stranded wires, do not solder the stranded wires.

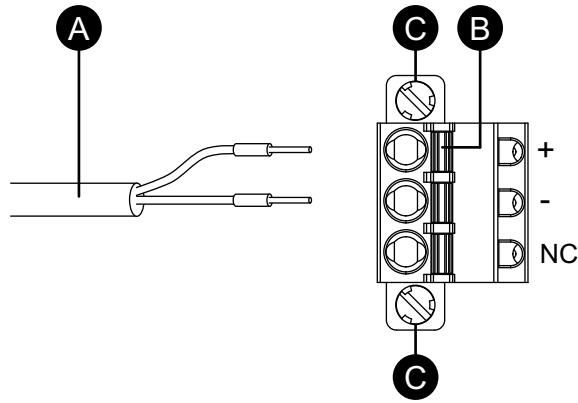

- A. Power cord
- B. Opening button
- C. Screw

6. After inserting all two power cord wires, insert the DC power connector into the power connector on this product.
7. Affix the screws on both sides of the connector.

NOTE: The necessary torque is 0.3 N•m (2.7 lb-in).

Power Supply Precautions

⚠ DANGER

SHORT CIRCUIT, FIRE, OR UNINTENDED EQUIPMENT OPERATION

- Install and fasten this product in an installation panel or cabinet prior to connecting power supply and communication lines.
- Securely attach power cables to an installation panel or cabinet.
- Avoid excessive force on the power cable.

Failure to follow these instructions will result in death or serious injury.

- This product's power cord should not be bundled with or kept close to main circuit lines (high voltage, high current), power lines, or input/output lines (such as communication wires), and their various systems should be kept separate. When power lines cannot be wired via a separate system, use shielded cables for input/output lines.
- An independent DC power supply is recommended for this product. (The DC power supply should be located close to the product, with twisted pair cabling as short as possible.)
- To increase noise resistance, attach a ferrite core to the power cable.

Power Supply Connections

- If the voltage variation is outside the prescribed range, connect a regulated power supply.

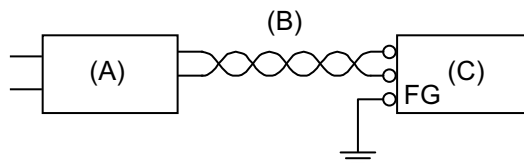

- A. Regulated power supply
- B. Twisted-pair cord
- C. This product

- The Vin- and SG (signal ground) / FG (functional ground) terminals are connected internally in this product. If the 0 Vdc output of the DC power supply is grounded, a ground loop may be formed, causing the return current of the power supply to flow through the FG path. It is recommended to design the system so that ground loops are not created, for example by ensuring that the DC power supply output is not grounded.

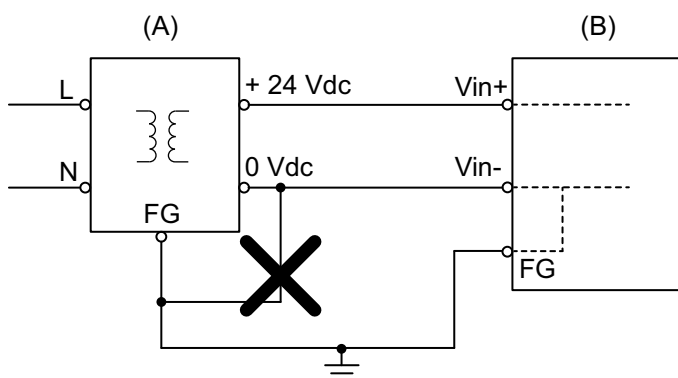

- A. DC power supply
- B. This product

Grounding

Independent Grounding

Always ground the FG (functional ground) terminal. Be sure to separate this product from the FG of other devices as shown below.

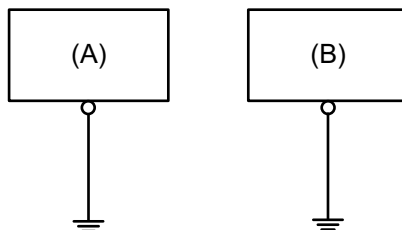

- A. This product
- B. Other equipment

Precautions

- Check that the grounding resistance is 100 Ω or less.*1
- The FG wire should have a cross sectional area 2 mm² (AWG14) or greater*1. Create the connection point as close as possible to this product, and make the wire as short as possible. When using a long grounding wire, replace the thin wire with a thicker wire, and place it in a duct.
- The SG (signal ground) and FG (functional ground) terminals are connected internally in this product. When connecting the SG line to another device, be sure that no ground loop is formed.

*1 Observe local codes and standards.

Common Grounding

Electromagnetic Interference (EMI) can be created if devices are improperly grounded. EMI can cause loss of communication. If independent grounding is not possible, use a common grounding point as shown in the configuration below. Do not use any other configuration for common grounding.

Correct grounding

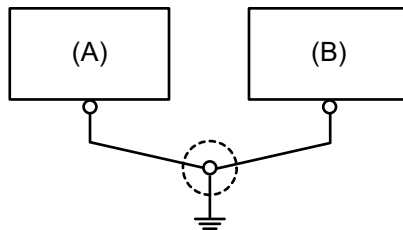

- A. This product
- B. Other equipment

Incorrect grounding

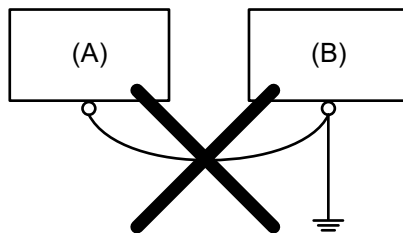

- A. This product
- B. Other equipment

M.2 SSD/M.2 Card Installation

Introduction

To install the M.2 SSD card or M.2 card, opening the maintenance hatch is required. The following describes how to open the maintenance hatch.

⚡⚠ DANGER**HAZARD OF ELECTRIC SHOCK, EXPLOSION, OR ARC FLASH**

- Remove all power from the device before removing any covers or elements of the system, and prior to installing or removing any accessories, hardware, or cables.
- Unplug the power cable from both this product and the power supply prior to installing or removing the product.
- Always use a properly rated voltage sensing device to confirm power is off where and when indicated.
- Replace and secure all covers or elements of the system before applying power to this product.
- Use only the specified voltage when operating this product. This product is designed to use 24 Vdc. Always check whether your device is DC powered before applying power.

Failure to follow these instructions will result in death or serious injury.

⚠ CAUTION**STORAGE DEVICE DAMAGE AND DATA LOSS**

- Remove all power before making any contact with an installed storage device.
- Use only our optional storage devices for this product.
- Make sure you regularly back up the data since storage devices have a life span and accidental data loss can occur at any time.
- Confirm the storage device is correctly oriented before insertion.
- Do not bend, drop, or strike the storage device.
- Do not touch inside the storage device or its connectors.
- Do not disassemble or modify the storage device.
- Keep the storage device dry.

Failure to follow these instructions can result in injury or equipment damage.

⚠ CAUTION**EQUIPMENT DAMAGE**

Do not touch the circuit boards, parts or internal cables with your hand or metal objects, taking care to prevent electrostatic discharge and contamination of foreign substances.

Failure to follow these instructions can result in injury or equipment damage.

NOTICE**ELECTROSTATIC DISCHARGE**

Take the necessary protective measures against electrostatic discharge, such as wearing an anti-static wrist strap, before attempting to remove the cover.

Failure to follow these instructions can result in equipment damage.

NOTICE

BROKEN ENCLOSURE

Do not exert more torque than the amount specified.

Failure to follow these instructions can result in equipment damage.

Opening the Maintenance Hatch

1. Disconnect the power supply from this product.
2. Touch the housing or ground connection (not the power supply) to discharge any electrostatic charge from your body.
3. Place the product face down on a clean, flat, level surface.
4. Remove 2 screws of the maintenance hatch.

NOTE: Using a Phillips screwdriver #1 is recommended.

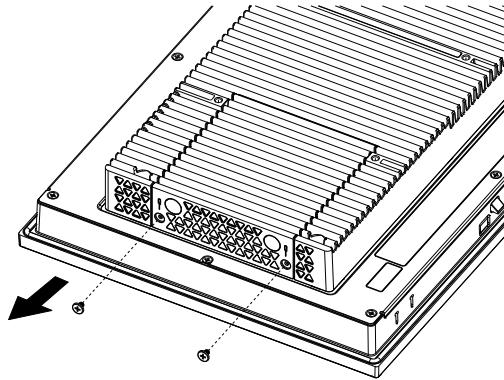

5. Remove the cover.

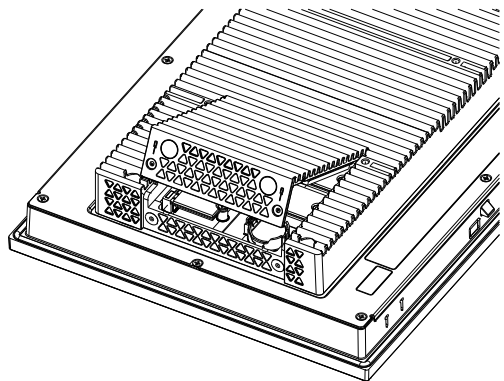

6. After installing the M.2 SSD or M.2 card, place the cover and tighten the screw.

NOTE: The necessary torque is 0.2 N•m (1.8 lb-in).

Installing M.2 SSD (SSD1)

In the M.2 SSD slot (SSD1), the main storage for the product is already inserted. The following describes how to replace the M.2 SSD card in SSD1.

NOTE:

- The SSD1 slot supports M.2 SSD Type 2280 (default card) and 2242. The key ID is Key M.
- Although the SIM card slot on the SSD2 slot is visible, it is not available.

1. Remove the maintenance hatch cover referring to *Opening the Maintenance Hatch*, page 47.
2. Remove the screw from the M.2 SSD card in SSD1.

NOTE: Using a Phillips screwdriver #1 is recommended.

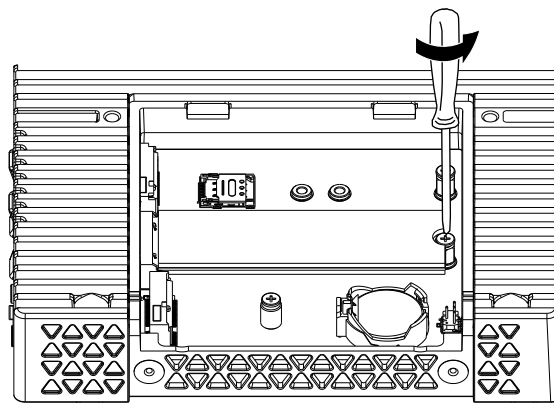

3. Pull out the M.2 SSD card from the slot.

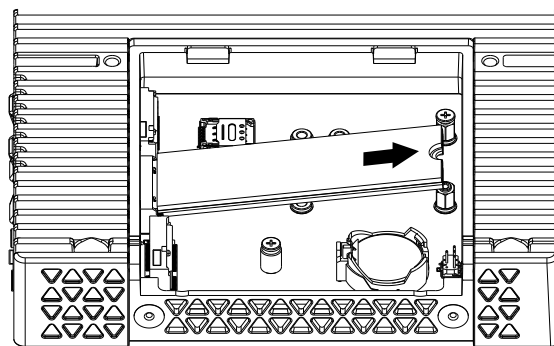

4. Insert a new M.2 SSD card into the connector diagonally, then push from above.

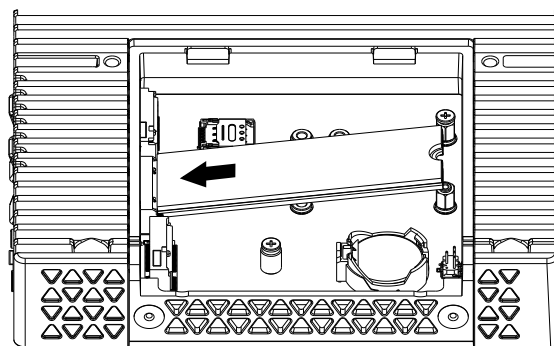

5. The following shows the screw position for each type of the M.2 SSD card.

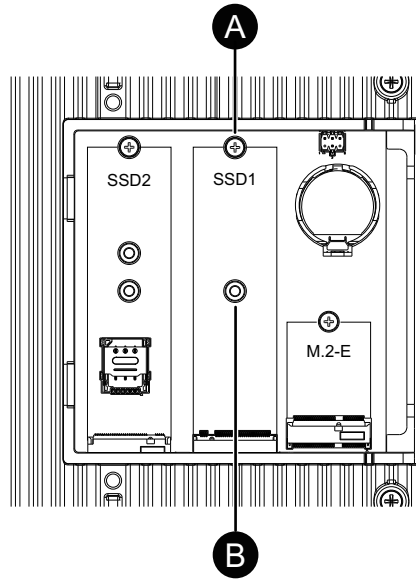

A. For Type 2280

B. For Type 2242

6. When inserting Type 2280 M.2 SSD card, tighten the screw removed in step 2 in the position indicated by A.

When inserting Type 2242, remove the spacer attached in the position indicated by A with a 5 mm box wrench.

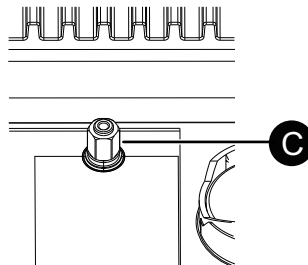

C. Spacer

Attach the spacer with a 5 mm box wrench in the position indicated by B, and tighten the screw removed in step 2 on it.

NOTE:

- The necessary torque for the spacer is 0.35 N•m (3.1 lb-in).
- The necessary torque for the screw is 0.2 N•m (1.8 lb-in).

7. Place the maintenance hatch cover and tighten the screw.

NOTE: The necessary torque is 0.2 N•m (1.8 lb-in).

Installing M.2 SSD (SSD2)

In the M.2 SSD slot (SSD2), you can insert an M.2 SSD card as a secondary storage.

NOTE:

- The SSD2 slot supports M.2 SSD Type 2280, 2252 and 2242. The key ID is Key B.
- Although the SIM card slot on the SSD2 slot is visible, it is not available.

1. Remove the maintenance hatch cover referring to *Opening the Maintenance Hatch*, page 47.
2. Remove the screw in SSD2.

NOTE: Using a Phillips screwdriver #1 is recommended.

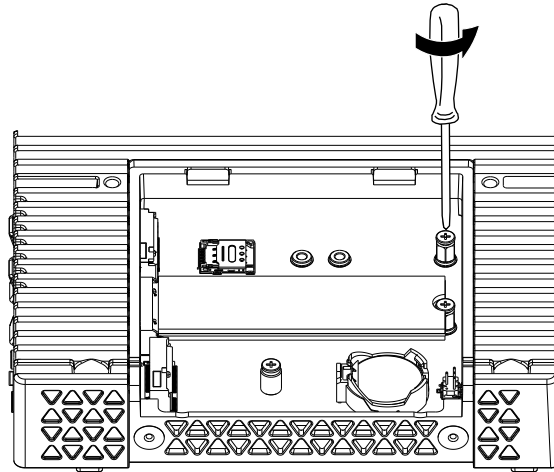

3. Insert an M.2 SSD card into the connector diagonally, then push from above.

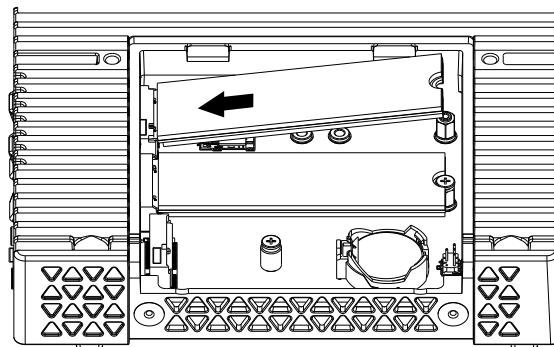

4. The following shows the screw position for each type of the M.2 SSD card.

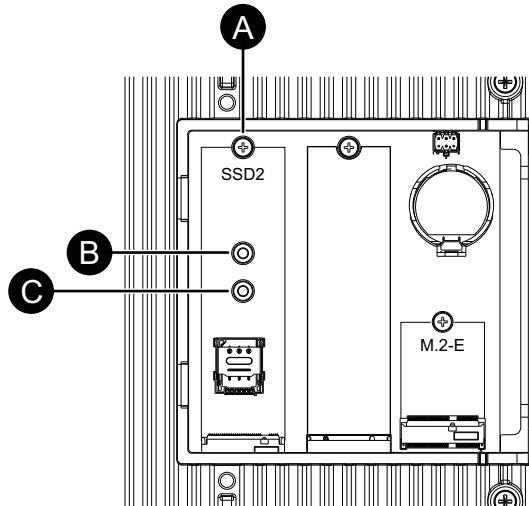

A. For Type 2280

B. For Type 2252

C. For Type 2242

5. When inserting Type 2280 M.2 SSD card, tighten the screw removed in step 2 in the position indicated by A.

When inserting Type 2242 or 2252, remove the spacer attached in the position indicated by A with a 5 mm box wrench.

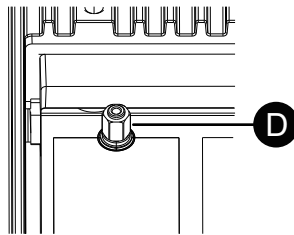

D. Spacer

When inserting Type 2252, attach the spacer with a 5 mm box wrench in the position indicated by B, and tighten the screw removed in step 2 on it.

When inserting Type 2242, attach the spacer with a 5 mm box wrench in the position indicated by C, and tighten the screw removed in step 2 on it.

NOTE:

- The necessary torque for the spacer is 0.35 N•m (3.1 lb-in).
- The necessary torque for the screw is 0.2 N•m (1.8 lb-in).

6. Place the maintenance hatch cover and tighten the screw.

NOTE: The necessary torque is 0.2 N•m (1.8 lb-in).

Installing M.2-E Card

In the M.2-E slot (M.2-E), you can insert an M.2 Key E card for a WiFi/Bluetooth connection.

NOTE: The M.2-E slot supports M.2 Key E Type 2230.

1. Remove the maintenance hatch cover referring to Opening the Maintenance Hatch, page 47.
2. Remove the screw in M.2-E.

NOTE: Using a Phillips screwdriver #1 is recommended.

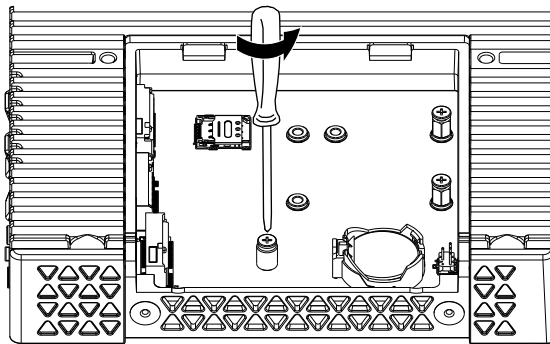

3. Insert an M.2 Key E card into the connector diagonally, then push from above.

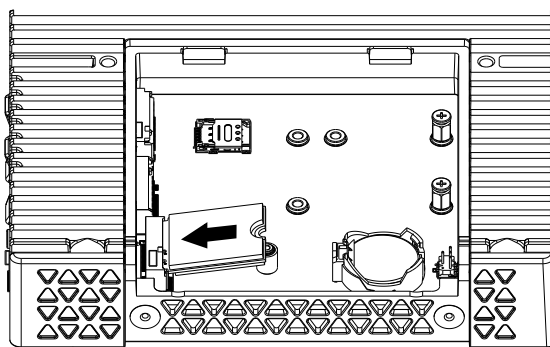

4. Tighten the screw removed in step 2.
NOTE: The necessary torque is 0.2 N•m (1.8 lb-in).
5. Place the maintenance hatch cover and tighten the screw.
NOTE: The necessary torque is 0.2 N•m (1.8 lb-in).

USB Type A Cable Clamp

Attaching USB Cable Clamp

When using a USB device, attach a USB cable clamp to the USB interface to prevent the USB cable from being disconnected.

NOTE: The USB cable clamp is an optional item (HMIZCCLUSA) and needs to be purchased separately.

▲ WARNING

EXPLOSION HAZARD

- Do not disconnect equipment while the circuit is live or unless the area is known to be free of ignitable concentrations.
- Remove power before attaching or detaching any connectors to or from this product.
- Ensure that power, communication, and accessory connections do not place excessive stress on the ports. Consider the vibration in the environment when making this determination.
- Securely attach power, communication, and external accessory cables to the panel or cabinet.
- Use only commercially available USB cables.
- Use only non-incendive USB configurations.
- Confirm that the USB cable has been attached with the USB cable clamp before using the USB interface.

Failure to follow these instructions can result in death, serious injury, or equipment damage.

NOTE: Watch your fingers. The edge of the clip is sharp.

1. Mount the clip to the USB mark  on the USB connector shell so that it overlaps. The clip matches a length of 27 to 43.5 mm (1.06 to 1.71 in) for the USB cable connector.

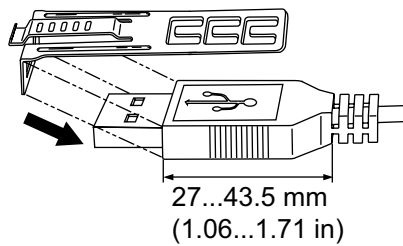

NOTE: When installing clamps to reduce cable stress onto both the upper port and lower port, at the upper port overlay the clip on the side with the USB mark, and on the lower port the side without the USB mark. Make sure the ties do not interfere with the other.

2. Align the clip and the USB cable connector shell. Adjust the position of the holes where the clip is attached. To ensure stability, select the clip-hole position that is closest to the base of the connector shell.

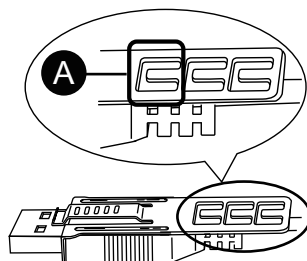

A. Pass the tie through here.

3. As shown, pass the tie through the clip hole. Next, turn the tie and pass it through the head so that the USB cable can pass through the center of the tie loop and that the tie can pass through the head. The clip is now attached to the USB cable.

NOTE:

- Check the direction of the head beforehand. Make sure the USB cable is through the center of the tie loop and that the tie can pass through the head.
- You can substitute the tie provided with HMIZCCLUSA or other commercially available ties with a width of 4.8 mm (0.19 in) and thickness of 1.3 mm (0.05 in).

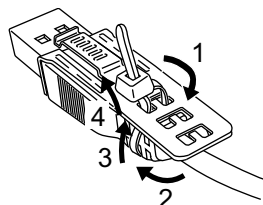

4. While pressing the grip on the clip, insert the cable from step 3 all the way into the USB host interface. Make sure that the tab of the clip is secured to the USB cable attached to this product.

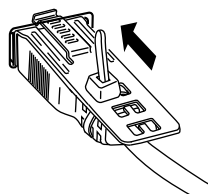

Removing USB Cable Clamp

1. When USB cables with the clamps are connected to both the upper port and lower port, remove the cable with the clamp from the upper port.

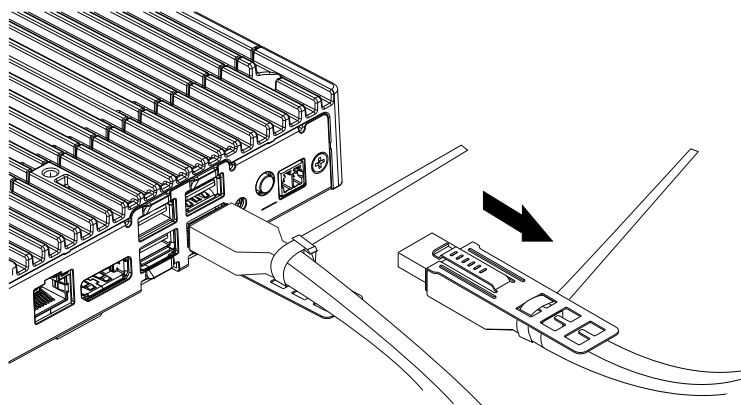

2. Loosen the cable tie of the USB clamp in the lower port.

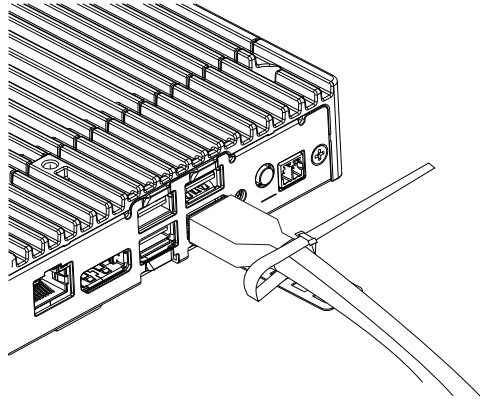

3. Remove the cable.

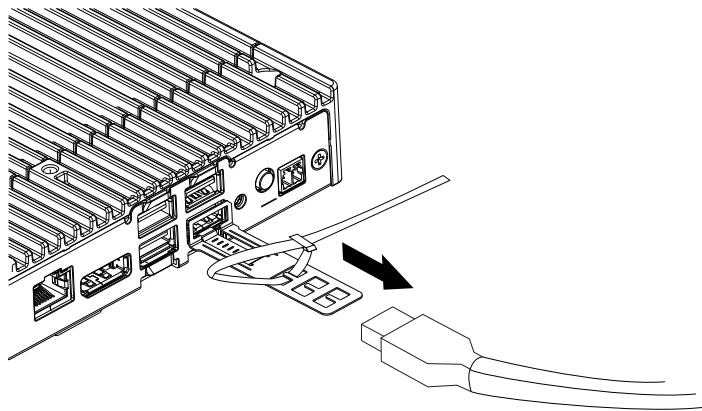

4. Remove the USB clamp.

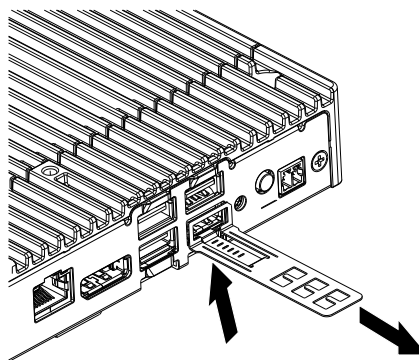

Maintenance

What's in This Chapter

Regular Cleaning	56
Periodic Check Points.....	56
Replacing the Battery	57
Replacing the Backlight	58

Regular Cleaning

Cleaning this product

NOTICE

EQUIPMENT DAMAGE

- Power off this product before cleaning it.
- Do not use hard or pointed objects to operate the touch panel.
- Do not use paint thinner, organic solvents, or a strong acid compound to clean the unit.

Failure to follow these instructions can result in equipment damage.

When this product gets dirty, wipe this product with a soft, dry cloth or a soft cloth soaked in only water and wrung tightly.

NOTE: When the product is very dirty, soak the soft cloth in water with a neutral detergent, wring the cloth tightly and wipe the product while avoiding the product label.

Periodic Check Points

Operation Environment

- Is the ambient air temperature within the allowable range? Refer to Environmental Specifications, page 22.
- Is the ambient air humidity within the specified range? Refer to Environmental Specifications, page 22.

When this product is inside a panel, the ambient environment refers to the interior of the panel.

Electrical Specifications

- Is the input voltage appropriate? Refer to Electrical Specifications, page 21.
- Are all power cords and cables connected properly? Are there any loose cables?
- Are all installation fasteners holding the unit securely?

Unit Disposal

When disposing this product, dispose it in a manner appropriate to, and in accordance with, your country's industrial machinery disposal/recycling standards.

Replacing the Battery

This product uses a primary battery for data backup of the internal clock. If the battery is depleted, the clock data will be lost. Use only CR-2032 lithium metal battery for the replacement (CR-2032 by Maxell is recommended).

⚡⚠ DANGER

HAZARD OF ELECTRIC SHOCK, EXPLOSION, OR ARC FLASH

- Follow the procedures step by step to replace the battery correctly and safely.
- Before replacing the battery, turn off this product's power.

Failure to follow these instructions will result in death or serious injury.

⚠ DANGER

EXPLOSION, FIRE, OR CHEMICAL HAZARD

- Use only the identical replacement battery for this product.
- Do not cause a short circuit.
- Recycle or properly dispose of used batteries.
- Do not recharge, disassemble or heat above 80 °C (176 °F).
- Use your hands or insulated tools to remove or replace the battery.
- Maintain proper polarity when inserting and connecting a new battery.

Failure to follow these instructions will result in death or serious injury.

NOTICE

LOSS OF DATA

- Replace the battery regularly every five years after you purchase this product.
- Insert the battery before reconnecting the power supply.
- Allow only qualified personnel to replace the battery.

Failure to follow these instructions can result in equipment damage.

NOTE: After reconnecting the power supply, set up the clock again.

1. Disconnect the power supply from this product.
2. Touch the housing or ground connection to discharge any electrostatic charge from your body.
3. Place the product face down on a clean, flat, level surface.
4. Remove the maintenance hatch cover referring to [Opening the Maintenance Hatch](#), page 47.
5. There is a clearance gap in the battery holder.

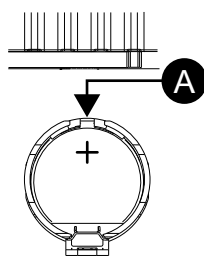

A. Clearance gap

6. Insert the tip of a thin-tipped flat head screwdriver in the gap, and pull out the battery.

NOTE: A flat head screwdriver of 2.00 mm or less is recommended.

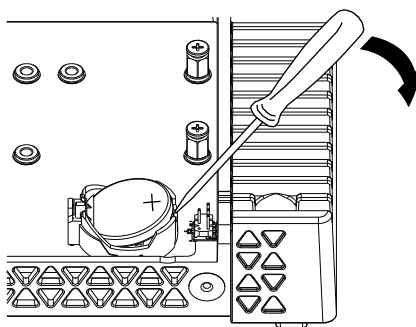

7. Insert a new battery on the battery holder so that the "+" marking on the battery comes on top.
8. Place the maintenance hatch cover and tighten the screw.

NOTE: The necessary torque is 0.2 N•m (1.8 lb-in).

Replacing the Backlight

Not user replaceable. Please contact customer support.

Cybersecurity

What's in This Chapter

Cybersecurity Guideline..... 59
Security Seal 59

Cybersecurity Guideline

Use this product inside a secure industrial automation and control system. Total protection of components (equipment/devices), systems, organizations, and networks from cyber attack threats requires multi-layered cyber risk mitigation measures, early detection of incidents, and appropriate response and recovery plans when incidents occur. For more information about cybersecurity, refer to the Harmony HMI/iPC Cybersecurity Guide.

<https://www.se.com/ww/en/download/document/EIO0000004948/>

▲ WARNING
POTENTIAL COMPROMISE OF SYSTEM AVAILABILITY, INTEGRITY, AND CONFIDENTIALITY
<ul style="list-style-type: none">• Change default passwords at first use to help prevent unauthorized access to device settings, controls and information.• Disable unused ports/services and default accounts, where possible, to minimize pathways for malicious attacks.• Place networked devices behind multiple layers of cyber defenses (such as firewalls, network segmentation, and network intrusion detection and protection).• Apply the latest updates and hotfixes to your Operating System and software.• Use cybersecurity best practices (for example: least privilege, separation of duties) to help prevent unauthorized exposure, loss, modification of data and logs, interruption of services, or unintended operation.
Failure to follow these instructions can result in death, serious injury, or equipment damage.

Security Seal

This product has a security seal attached, which helps detect unauthorized repairs or modifications to the product. Once the security seal is removed or torn, it cannot be reapplied, increasing the product's security risk.

▲ WARNING
POTENTIAL COMPROMISE OF SYSTEM AVAILABILITY, INTEGRITY, AND CONFIDENTIALITY
<ul style="list-style-type: none">• Do not remove or tear the security seal on the product.• Do not use products with removed or torn security seals.
Failure to follow these instructions can result in death, serious injury, or equipment damage.

NOTE: When the maintenance hatch cover is open for installing or replacing the M.2 SSD, M.2 card, or battery, it is recommended to take precautions to prevent unauthorized repairs or tampering through the maintenance hatch. This will help ensure that malicious individuals cannot gain access to the interior after the work is completed. Please note that the maintenance hatch cover should not be opened unnecessarily.

System Settings

For system settings on this product, refer to Harmony PSA6 Windows System Setting User Guide.

Schneider Electric
35 rue Joseph Monier
92500 Rueil Malmaison
France

www.se.com

As standards, specifications, and design change from time to time, please ask for confirmation of the information given in this publication.

© 2026 – Schneider Electric. All rights reserved.

EIO0000005603.01