

SeT Series

MCS_eT

Digitally Native up to 24 kV

Air-insulated Switchgear

With EvoPacT HVX Vacuum Circuit Breaker

User and Maintenance Guide

BQT6904800-04

04/2026



Legal Information

The information provided in this document contains general descriptions, technical characteristics and/or recommendations related to products/solutions.

This document is not intended as a substitute for a detailed study or operational and site-specific development or schematic plan. It is not to be used for determining suitability or reliability of the products/solutions for specific user applications. It is the duty of any such user to perform or have any professional expert of its choice (integrator, specifier or the like) perform the appropriate and comprehensive risk analysis, evaluation and testing of the products/solutions with respect to the relevant specific application or use thereof.

The Schneider Electric brand and any trademarks of Schneider Electric SE and its subsidiaries referred to in this document are the property of Schneider Electric SE or its subsidiaries. All other brands may be trademarks of their respective owner.

This document and its content are protected under applicable copyright laws and provided for informative use only. No part of this document may be reproduced or transmitted in any form or by any means (electronic, mechanical, photocopying, recording, or otherwise), for any purpose, without the prior written permission of Schneider Electric.

Schneider Electric does not grant any right or license for commercial use of the document or its content, except for a non-exclusive and personal license to consult it on an "as is" basis.

Schneider Electric reserves the right to make changes or updates with respect to or in the content of this document or the format thereof, at any time without notice.

To the extent permitted by applicable law, no responsibility or liability is assumed by Schneider Electric and its subsidiaries for any errors or omissions in the informational content of this document, as well as any non-intended use or misuse of the content thereof.

SeT Series

Featuring outstanding medium-voltage (MV) and low-voltage (LV) switchboards, motor control centres and power distribution solutions for high-performance power applications, Schneider Electric's SeT Series is optimized solutions based on high levels of safety and an optimised footprint. Built on a modular architecture and incorporating smart connected devices for maximum safety, reliability, performance and energy efficiency, the SeT Series is delivered to customers directly from our Schneider Electric plants or via a global network of licensed partner panel builders, who are trained and audited to provide quality equipment and support.

Table of Contents

Safety Information.....	5
Safety Precautions	6
About the Document.....	7
Safety Provisions	10
General.....	13
Equipment Marking.....	13
Disposal After the End of the Useful Life	13
Design and Description.....	14
Cubicle Design	14
Feeder with Contactor Cubicle	15
I/F Cubicle.....	16
BSC-BSRCubicle.....	17
BME Cubicle	18
Identification.....	19
Rating Plate	20
Labels and Indicators.....	21
Control Symbols of VCB	22
Labels and Indicators of E/S	23
Control Symbols of E/S	23
Medium Voltage Devices	24
EvoPacT HVX VCB.....	24
EvoPacT Metering Truck	25
CVX Contactor	26
MCSeT Cubicle Ratings.....	27
Heater.....	29
VDIS.....	30
Range of VDIS Unit Variants.....	30
Accessing the Test Points of the VDIS	31
PowerLogic PD100.....	32
Accessories	33
Transport Trolley	33
Operation Accessories.....	35
Screw Fastenings	36
Auxiliary Products.....	37
Interlocks.....	38
Mechanical Interlocks	38
Electromagnetic Interlocks (Optional).....	40
Padlocks.....	40
Keylocks	43
Circuit Breaker Position Keylocks	43
E/S Keylock in OFF Position.....	45
E/S Keylock in ON Position	46
Operations	47
Operating the VCB	47
Charging the VCB Energy Storing Device	48
Switching the VCB Electrically	49

Switching the VCB Manually	49
Operating the CVX Contactor	51
Move the Truck into Service Position or Disconnected Position	53
Rack-in the truck from Disconnected Position into Service Position.....	54
Rack-out the Truck from Service Position into Disconnected Position.....	55
Switching the E/S Manually	56
Switching ON the E/S	56
Switching OFF the E/S	56
Switching the Contactor Cubicle E/S Manually	58
Switching ON the Contactor Cubicle E/S.....	58
Switching OFF the Contactor Cubicle E/S	59
Standard Switching Operations.....	60
Switching a Feeder	60
Earthing the Feeder Cable.....	60
Coupling Busbar Sections via BSC.....	61
Earthing the Busbar	62
Access to the MCSeT Cubicle Compartments	63
Access to the Cable Compartment.....	64
Access to the Cable Compartment from Front Side.....	64
Withdrawable VT Operation	69
Access to the Cable Compartment via the VCB Compartment.....	74
Access to the Cable Compartment from Rear Side AFLR.....	75
Access to the Contactor Cubicle Cable Compartment.....	77
Access to the EvoPacT HVX VCB Compartment.....	78
Opening and Closing the VCB Front Door.....	78
Removal and Insertion of LV Connector	79
Insertion of the EvoPacT HVX VCB into the Cubicle	80
Extraction of the EvoPacT HVX VCB from the Cubicle	84
Access to the Contactor Cubicle Switching Device Compartment	86
Access to the Busbar Compartment	88
Access to the Busbar Compartment from Front Side AFL.....	88
Access to the Busbar Compartment from Rear Side AFLR.....	89
Maintenance	91
Safety Provisions.....	91
Overview	92
Checklist for Maintenance Activities	95
Cleaning	97
Avoid Condensation.....	97
Corrosion Protection	97
Maintenance Specifications.....	98
Lubrication Instructions	99
Treatment of Firmly Screw-Connected Contact Surfaces	100
PowerLogic PD100 Operation and Maintenance	101
Replacement of Components and Cubicles	102
Glossary	103

Safety Information

Important Information

Read these instructions carefully, and look at the equipment to become familiar with the device before trying to install, operate, service, or maintain it. The following special messages may appear throughout this documentation or on the equipment to warn of potential hazards or to call attention to information that clarifies or simplifies a procedure.





The addition of this symbol to a “Danger” or “Warning” safety label indicates that an electrical hazard exists which will result in personal injury if the instructions are not followed.



This is the safety alert symbol. It is used to alert you to potential personal injury hazards. Obey all safety messages that follow this symbol to avoid possible injury or death.

 DANGER
DANGER indicates a hazardous situation which, if not avoided, will result in death or serious injury.

 WARNING
WARNING indicates a hazardous situation which, if not avoided, could result in death or serious injury.

 CAUTION
CAUTION indicates a hazardous situation which, if not avoided, could result in minor or moderate injury.

NOTICE
NOTICE is used to address practices not related to physical injury.

Please Note

Electrical equipment should be installed, operated, serviced, and maintained only by qualified personnel. No responsibility is assumed by Schneider Electric for any consequences arising out of the use of this material.

A qualified person is one who has skills and knowledge related to the construction and operation of electrical equipment and its installation, and has received safety training to recognize and avoid the hazards involved.

Safety Precautions

Safety Rules

DANGER

HAZARD OF ELECTRIC SHOCK, EXPLOSION, OR ARC FLASH

- Apply appropriate Personal Protective Equipment (PPE) and follow safe electrical work practices. See standards or local equivalent.
- This EvoPacT HVX Vacuum Circuit Breaker and the MCSeT equipment must only be installed and serviced by qualified electrical personnel.
- Perform work only after reading and understanding all of the instructions contained in this guide.
- Turn off all the power sources before working on or inside the equipment.
- Turn off or trip the Vacuum Circuit Breaker (VCB) and discharge the mechanism.
- Always use a properly calibrated voltage sensing device to confirm power is off.
- Use only Schneider Electric specific tools (operating crank, extraction table, and so on).
- Check all devices, covers, and doors are in correct position before turning on the power.
- Beware of potential hazards and carefully inspect the work area for tools and objects that may have been left inside the equipment.
- Do not modify the mechanical or electrical parts.
- Do not bypass the interlocks before operation.
- Do not operate with protective barriers removed.

Failure to follow these instructions will result in death or serious injury.

NOTICE

HAZARD OF INAPPROPRIATE HANDLING AND STORING UNDER INADEQUATE CONDITIONS

- Comply with the handling rules and avoid causing any shocks to the device.
- If the equipment is stored before its final installation, observe the storage conditions.

Failure to follow these instructions can result in equipment damage.

Cleaning Instructions

DANGER

HAZARD OF ELECTRIC SHOCK, EXPLOSION, OR ARC FLASH

- Do not use solvents or alcohol for cleaning the equipment.
- Do not use high-pressure cleaner for cleaning the equipment.

Failure to follow these instructions will result in death or serious injury.

About the Document

Document Scope

This user and maintenance guide describes operation and maintenance of the air-insulated MV switchgears of the MCSeT with EvoPacT HVX VCB up to 24 kV. It is exclusively intended for use by the manufacturer's staff or by persons certified for the MCSeT with EvoPacT HVX VCB series (training certificate).

Read these instructions carefully and look at the equipment to become familiar with the device before trying to install, operate, service or maintain it.

This guide is an integral part of the product and must be stored so that it is readily accessible at all times and can be used by persons who are going to work on the switchgear. If the switchgear is relocated to another site, this guide must be passed on to the new operators along with the unit.

As our products are subject to continuous development; we reserve the right to make changes regarding the standards, illustrations and technical data described in this guide.

This guide does not describe every imaginable individual case or every customer-specific version of the product. For more information that is not included in this guide, contact Schneider Electric.

All dimensions not specified in detail are in millimeters.

Disclaimer of Liability

Air-insulated MV switchgears of the MCSeT with EvoPacT HVX VCB are designed exclusively for switching and distributing electrical power. They may only be used in the scope of the specified standards and the switchgear-specific technical data.

Schneider Electric shall not be held responsible for damage without following the below guidelines:

- Instructions in this guide are not complied with.
- The switchgear is not operated according to its intended use (see above).
- The switchgear is assembled, connected or operated improperly.
- Accessories or spare parts are used which have not been approved by the manufacturer.
- The switchgear is modified without the manufacturer's approval, or if inadmissible parts are added.
- No liability is accepted for parts provided by customers, for example Current Transformer (CT).

General Cybersecurity Information

In recent years, the growing number of networked machines and production plants has seen a corresponding increase in the potential for cyber threats, such as unauthorized access, data breaches, and operational disruptions. You must, therefore, consider all possible cybersecurity measures to help protect assets and systems against such threats.

To help keep your Schneider Electric products secure and protected, it is in your best interest to implement the cybersecurity best practices as described in the Cybersecurity Best Practices document.

Schneider Electric provides additional information and assistance:

- Subscribe to the Schneider Electric security newsletter.
- Visit the Cybersecurity Support Portal web page to:
 - Find Security Notifications.
 - Report vulnerabilities and incidents.
- Visit the Schneider Electric Cybersecurity and Data Protection Posture web page to:
 - Access the cybersecurity posture.
 - Learn more about cybersecurity in the cybersecurity academy.
 - Explore the cybersecurity services from Schneider Electric.

Related Documents

The following additional documents must be complied with:

- Purchase agreement with the stipulations regarding the switchgear-specific equipment and the legal details.
- The appropriate switchgear-specific circuit diagrams/documentation.
- The operating manuals of the LV devices installed in the switchgear (for example, voltage presence detecting systems and devices in LV cabinet).
- The assembly drawings supplied with the equipment.
- The assembly instructions of the manufacturer of the cable connection systems to be connected to the switchgear.
- The user guide of MV devices being used.

Title of the Document	Reference Number
EvoPacT HVX VCB	NRJCAT21051EN-IEC
Receipt Guide	BQT8677900
Civil Engineering Guide	BQT8706400
Installation Guide	BQT6904400

To find documents online, visit the Schneider Electric download center (www.se.com/ww/en/download/).

Information on Non-Inclusive or Insensitive Terminology

As a responsible, inclusive company, Schneider Electric is constantly updating its communications and products that contain non-inclusive or insensitive terminology. However, despite these efforts, our content may still contain terms that are deemed inappropriate by some customers.

Queries

For any questions, suggestions, or need of further information about this guide, contact Schneider Electric. For additional details, visit our website www.se.com.

For details of MCSeT switchgear expansion (either right or left side), it is recommended to contact Schneider Electric.

We always strive to provide you with the best-possible information for optimum, safe use of our products. Contact Schneider Electric if you have any recommendations, amendments, or proposals for improvement.

Safety Provisions

Before performing work on the cubicle, it is essential that you comply with the following instructions:

DANGER

HAZARD OF ELECTRIC SHOCK, EXPLOSION, OR ARC FLASH

Before removing covers and performing assembly or maintenance work:

- Ensure that the system is isolated from high voltage, supply voltage, and properly grounded.
- Ensure that the VCB/Contactor is in test condition, the Earthing Switch (E/S) is closed, and access is locked.
- Follow the Lock Out Tag Out (LOTO) process to perform any work on switchboard.
- Install barriers, cables, and polycarbonates in accordance with the design specifications wherever necessary.

Failure to follow these instructions will result in death or serious injury.

WARNING

HAZARD OF MOVABLE PARTS IN MECHANICAL DRIVES

Before performing mounting and maintenance work, comply with the below safety rules:

- Isolate from the supply voltage.
- Release the energy-storing device of the VCB by performing the OFF-ON-OFF operation.
- Activate the make-proof E/S to ON position, to ensure that the equipment is ready for use (if any).
- Do not remove the mechanisms during maintenance work.

Failure to follow these instructions can result in death, serious injury, or equipment damage.

WARNING

HAZARD OF SHARP-EDGED SHEET METAL AND METAL PARTS

During installation and maintenance work, comply with the below safety rules:

- Apply appropriate PPE and follow safe electrical work practices. See standards or local equivalent.
- Always cover sharp edges.

Failure to follow these instructions can result in death, serious injury, or equipment damage.

⚠ CAUTION
<p>HAZARD OF INADEQUATE STORING, INSTALLATION, AND USE CONDITIONS</p> <ul style="list-style-type: none"> • Respect the handling rules and avoid any shocks to the device. • Perform the maintenance and servicing operations described in the maintenance section of this guide. • Observe the normal service conditions described in this guide. • Before the VCB is installed in its final location, ensure that the storage conditions for the MSeT equipment and the VCB are complied. <p>Failure to follow these instructions can result in injury or equipment damage.</p>

Applicable Standards and Regulations

The applicable standards and regulations are as follows:

- Metal-enclosed AC switchgear for rated voltages > 1 kV up to including 52 kV: IEC 62271-200, Common specification: IEC 62271-1.
- The locally applicable accident prevention, operating, and work instructions should be complied.
- Assembly and maintenance: IEC 61936-1/EN 50522.
- Operation of electrical equipment: EN 50110-1.
- Loss of service continuity: IEC 62271-200: LSC 2B-PM.
- Type-tested.
- Tested for Internal arc classification up to A-FLR upto 40kA, for 1 s.
- Dimensioned for indoor installation.

NOTE:

- The national standards applicable in the country where the equipment is to be installed should be complied.
- Other standards or regulations have to be checked and accessed locally.

Table 1 Applicable Standards and Regulations for MSeT Cubicles

Designation	IEC Standard
Switchgear	IEC 62271-200
	IEC 62271-1
Internal arc classification (IAC)	IEC 62271-200
Circuit breaker	IEC 62271-100
E/S	IEC 62271-102
CT	IEC 61869-2
Voltage Transformer (VT)	IEC 61869-3
Voltage Detecting and Indicating Systems (VDIS)	IEC 61243-5
Protection against accidental contact, foreign bodies and water	IEC 62271-200
	IEC 60529
High-voltage fuse link	IEC 60644
	IEC 60282
Measuring relays and protection equipment	IEC 60255

Table 2 Degrees of Protection According to IEC 62271-200 and IEC 60529

Description	IPX Rating
Degree of protection of the switchgear enclosure	IP4X ⁽¹⁾
Degree of protection between the compartments of the cubicle	IP2X
⁽¹⁾ Other values are available on request.	

Environmental and Operating Conditions

MCS_eT is an indoor switchgear and may only be operated under normal conditions in accordance with IEC 62271-1.

Operation under conditions deviating from these is only admissible subject to consultation with and written approval from the manufacturer.

Table 3 Operating Conditions

Description	Values
Temperature class	-5 °C, indoor ⁽¹⁾
Ambient temperature minimum/maximum	-5 °C/ +40 °C ⁽¹⁾
Average value over 24 hours	≤ 35 °C ⁽¹⁾
Mean relative air humidity: 24 hours/1month	≤ 95%/≤ 90%
Installation altitude above sea level	≤ 1000 m ⁽¹⁾
⁽¹⁾ Other values are available on request.	

Behavior in Case of Incidents or Accidents

If an internal arc fault occurs, the MCS_eT switchgear is equipped with pressure relief absorbers or ports to help prevent the cubicles and switchgear from being blown off.

This user and maintenance guide does not include information regarding the safety of buildings in case of internal arc faults (pressure load of the switchgear room and necessary pressure relief ports). Pressure calculations for switchgear rooms, including recommendations for pressure relief ports, are available upon request for a fee. For more details, contact Schneider Electric.

In case of fire or internal arc faults, toxic and caustic decomposition products are produced. Comply with the locally applicable accident and safety provisions.

Make sure that the first-aid measures are taken in case of injury to persons.

General

Equipment Marking

⚠ ⚠ DANGER	
 DO NOT WALK OR STAND HERE	HAZARD OF ELECTRIC SHOCK, EXPLOSION, OR ARC FLASH It is strictly forbidden to walk on the parts with this label. Failure to follow these instructions will result in death or serious injury.

⚠ ⚠ DANGER	
	HAZARD OF ELECTRIC SHOCK, EXPLOSION, OR ARC FLASH It is strictly forbidden to remove the parts with this label when the equipment is energized. Failure to follow these instructions will result in death or serious injury.

⚠ WARNING	
	HAZARD OF FALLING <ul style="list-style-type: none"> • Do not walk upon the topsides of the switchgear cubicles. • When working on the top of the switchgear cubicles (such as during the installation of deflectors, fans, or pressure relief ducts), temporarily attach a sturdy base plate that is walkable. Failure to follow these instructions can result in death, serious injury, or equipment damage.

Disposal After the End of the Useful Life

A material and recycling data sheet can be provided on request for the disposal of MCS eT switchgear at the end of its service life.

Disposal is performed as a service by Schneider Electric service center which is subjected to payment.

Design and Description

Cubicle Design

The MCSeT range is available in the following cubicle layouts:

- Feeder with Contactor Cubicle (FC)
- Incomer or Feeder (I/F)
- Bus Section Coupler (BSC)
- Bus Section Riser (BSR)
- Busbar Metering and Earthing (BME)

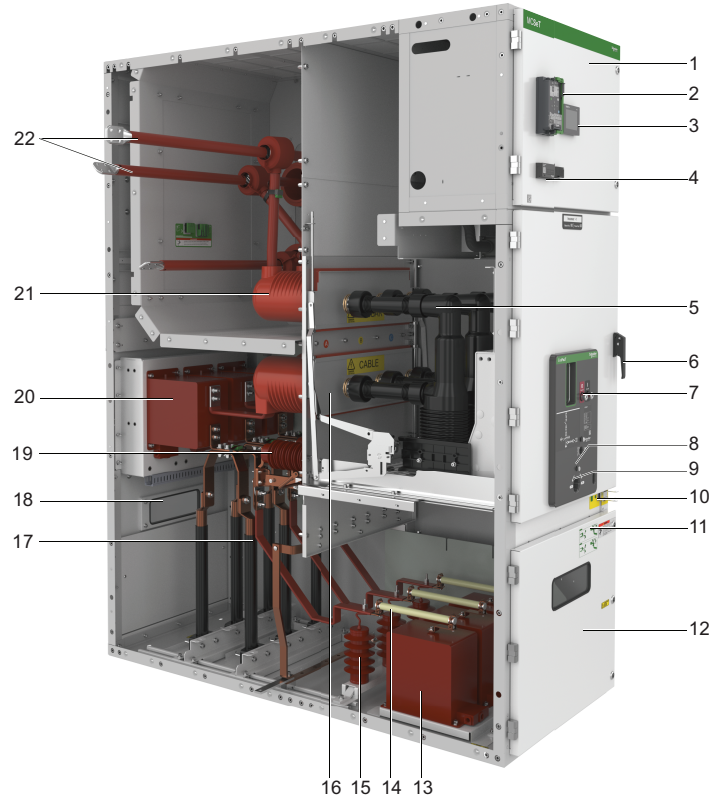

Figure 1
Cubicle Design

1	LV compartment	12	Cable compartment
2	P5 relay	13	VT
3	HMI screen	14	Fuse
4	VDIS and PowerLogic Partial Discharge100 (PD100)	15	Surge arrester
5	EvoPacT HVX VCB	16	Shutter
6	Handle	17	Cables
7	Switch OFF/ON push buttons of EvoPacT HVX VCB	18	Position inspection window for cables, VT, and E/S from rear window.
8	Access to spring charge	19	E/S
9	Access to rack-in/rack-out	20	CT
10	Operator interface of the E/S	21	Spout
11	Label of E/S manual operating instruction	22	Busbar

NOTE: The images shown here are for illustration purpose only.

Feeder with Contactor Cubicle

Feeder with contactor cubicle are available with a maximum rated voltage of 12 kV.

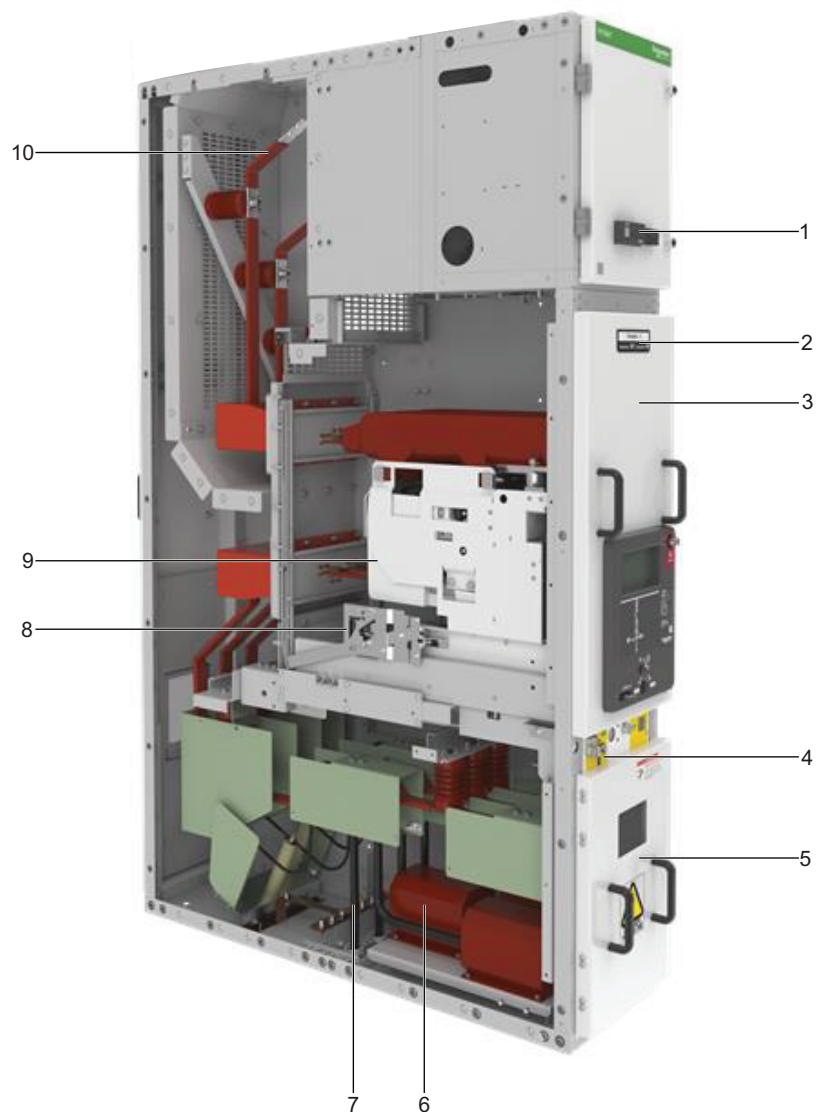

Figure 2
Feeder with Contactor (FC)

1	VDIS and PowerLogic PD100	6	CT
2	Nameplate	7	Cables
3	Door of switching device compartment	8	Shutter actuation
4	Operator of the E/S	9	Truck-type vacuum contactor CVX with fuses
5	Cable compartment	10	Busbars

I/F Cubicle

I/F Cubicle

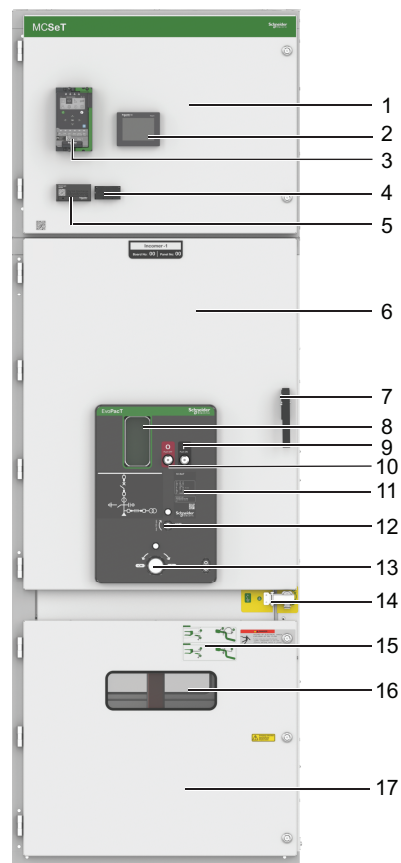

Figure 3
I/F Cubicle

1	LV compartment	10	Switch OFF push button of EvoPacT HVX VCB
2	HMI screen	11	Rating plate
3	P5 relay	12	Access to spring charge
4	VDIS	13	Access to Rack-in/Rack-out
5	PowerLogic PD100	14	Operator interface of the E/S
6	EvoPacT HVX VCB compartment	15	Label of E/S manual operating instruction
7	Handle	16	Position inspection window for cables from rear window and VT
8	Position inspection windows of the withdrawable part	17	Cable compartment
9	Switch ON push button of EvoPacT HVX VCB		

NOTE: The images shown here are for illustration purpose only.

BSC-BSRCubicle

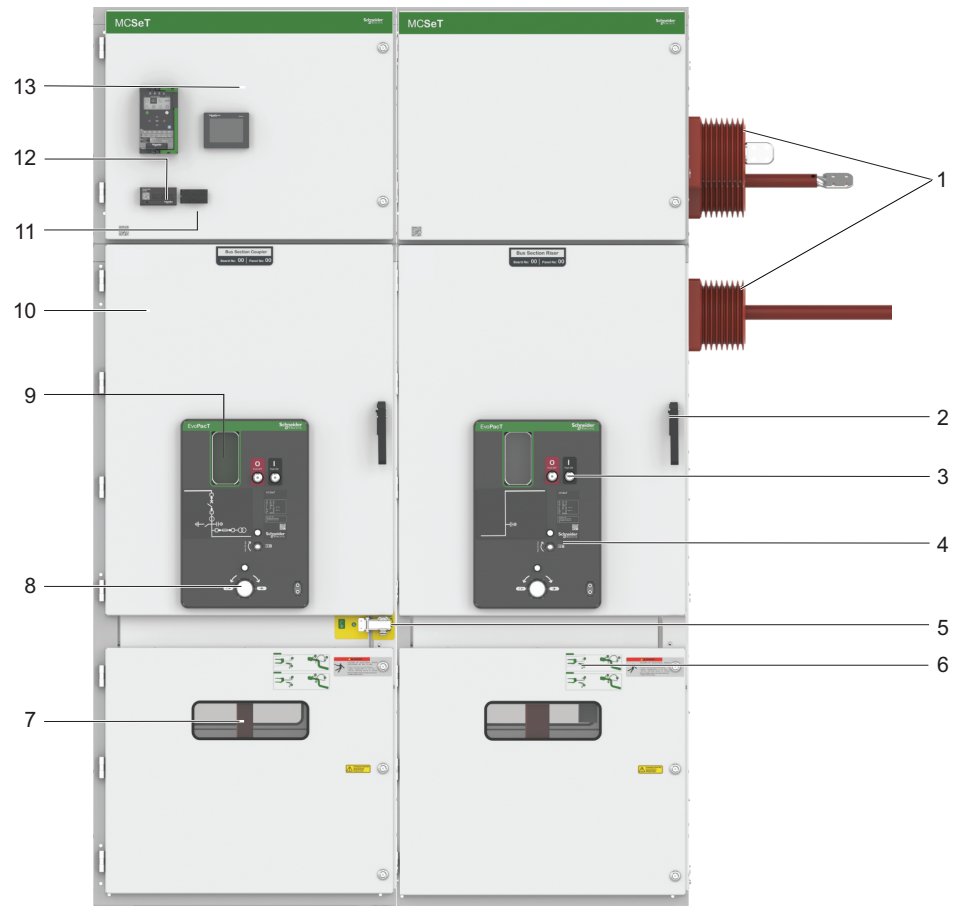

Figure 4
BSC-BSR Cubicles

- | | | | |
|---|--|----|--|
| 1 | Busbars | 8 | Rack-in/rack-out |
| 2 | Handle | 9 | Position inspection windows of the withdrawable part |
| 3 | Switch ON/OFF push button of EvoPacT HVX VCB | 10 | EvoPacT HVX VCB compartment |
| 4 | Rating plate | 11 | VDIS |
| 5 | Operator interface of the E/S | 12 | PowerLogic PD100 |
| 6 | Label of E/S manual operating instruction | 13 | LV compartment |
| 7 | Position inspection window for VT | | |

NOTE: The images shown here are for illustration purpose only.

BME Cubicle

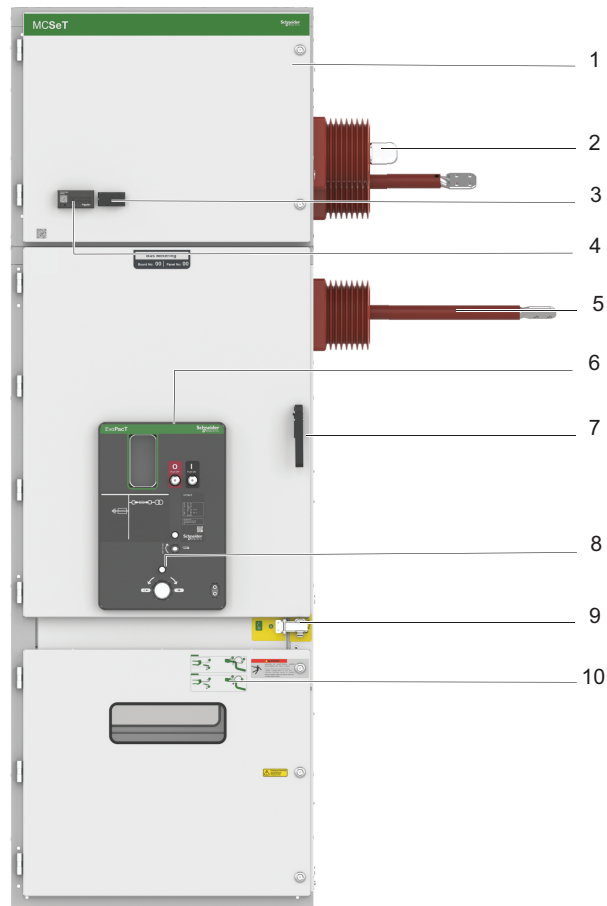

Figure 5
BME Cubicle

1	LV compartment	6	MV cubicle
2	Bushing	7	Handle
3	VDIS	8	Access to rack-in/rack-out
4	PowerLogic PD100	9	Operator interface of the E/S
5	Busbars	10	Label of E/S manual operating instruction

NOTE: The images shown here are for illustration purpose only.

Identification

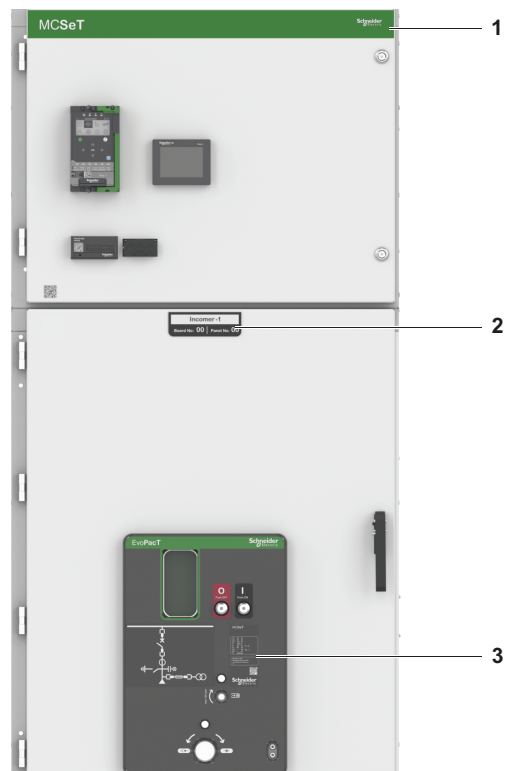

Figure 6
Labels on the Cubicle Example shows I/F cubicle

- 1 Brand name
- 2 Cubicle type (customer specific)
- 3 Rating plate

NOTE: The images shown here are for illustration purpose only.

Rating Plate

The type designation on the rating plate specifies the technical data for the cubicles. Refer to Figure 7.

To access this information, flash the QR code with smartphone or connected tablet. This will direct to the website containing the data relating to the device.

When submitting enquiries to the manufacturer or ordering spare parts, the following information is required:

- Type designation
- Job number

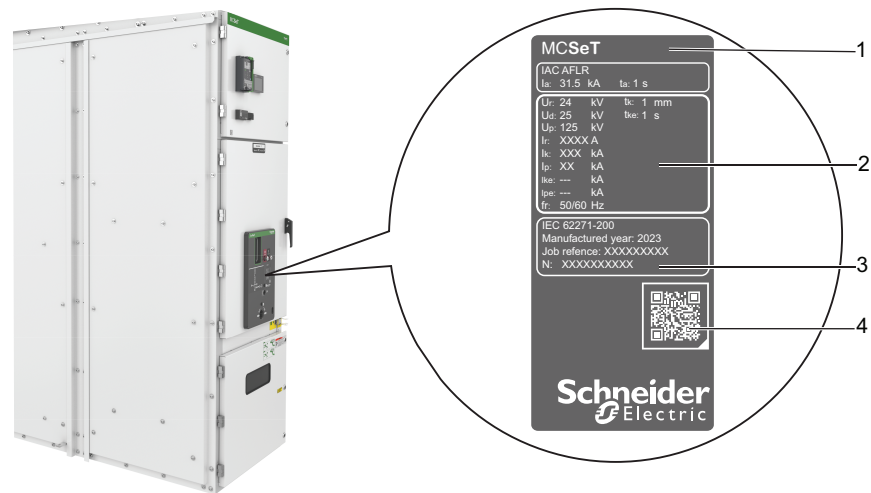

Figure 7
Components of Rating Plate

- | | | | |
|---|------------------|---|----------------------------------|
| 1 | Type designation | 3 | Job number |
| 2 | Technical data | 4 | QR code with product information |

NOTE: The images shown here are for illustration purpose only.

Labels and Indicators

Labels and Indicators on the VCB Cubicle

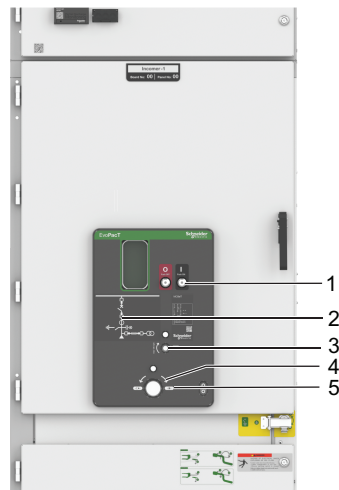

Figure 8
Example of Front View Indicators of I/F Cubicle

- | | | | |
|---|--|---|---|
| 1 | Switch ON/OFF guide of EvoPacT HVX VCB | 4 | Rack-in/rack-out manual operating instruction |
| 2 | Single line diagram | 5 | Rack-in/rack-out position indicators |
| 3 | Access to spring charge | | |

NOTE: The images shown here are for illustration purpose only.

Labels and Indicators on the Feeder with Contactor Cubicle

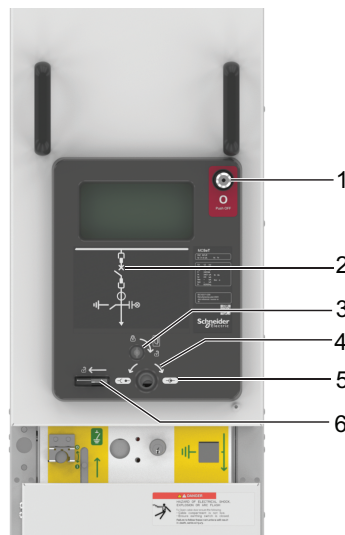

Figure 9
Labels and Indicators on the Feeder with Contactor Cubicle

- | | | | |
|---|---|---|--|
| 1 | Switch OFF guide of CVX contactor | 4 | Rack-in/rack-out manual operating instruction |
| 2 | Single line diagram | 5 | Rack-in/rack-out position indicators |
| 3 | Locking mechanism for switching device compartment door | 6 | Interlocking slide for manual actuation of the truck |

Control Symbols of VCB

Table 4 Rack-in/Rack-out Symbols











Description	Symbols
Manual operation instruction for rack-in/ rack-out	
Connected/service position	
Disconnected/test position	

Table 5 EvoPacT HVX VCB Symbols

Description	Symbols	Description	Symbols
ON push button		Spring discharged	
OFF push button		Operating counter	
Spring charged and ready-to-close indicator		Padlock for push button selector (optional feature)	
VCB OFF		VCB ON	

Labels and Indicators of E/S

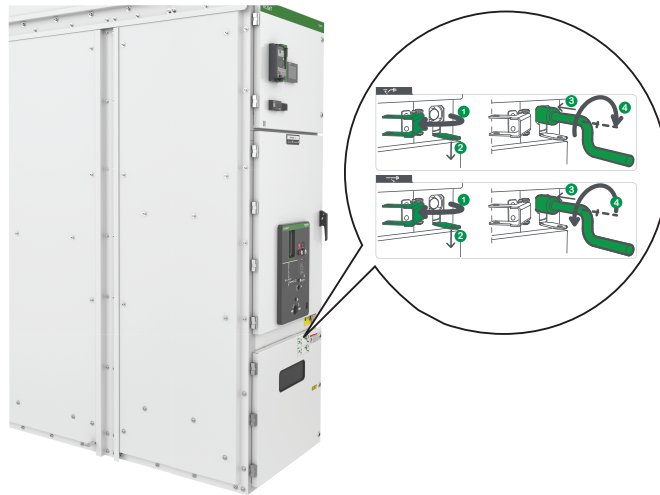

Figure 10
Label of E/S Manual Operating Instructions



Figure 11
E/S Status Indicator

Control Symbols of E/S

Table 6 Control Symbols of E/S

Description	Symbols	Description	Symbols
Operation position		Closed E/S mechanical indicator	
Open E/S mechanical indicator		Position can be locked using pad lock	

Medium Voltage Devices

EvoPacT HVX VCB

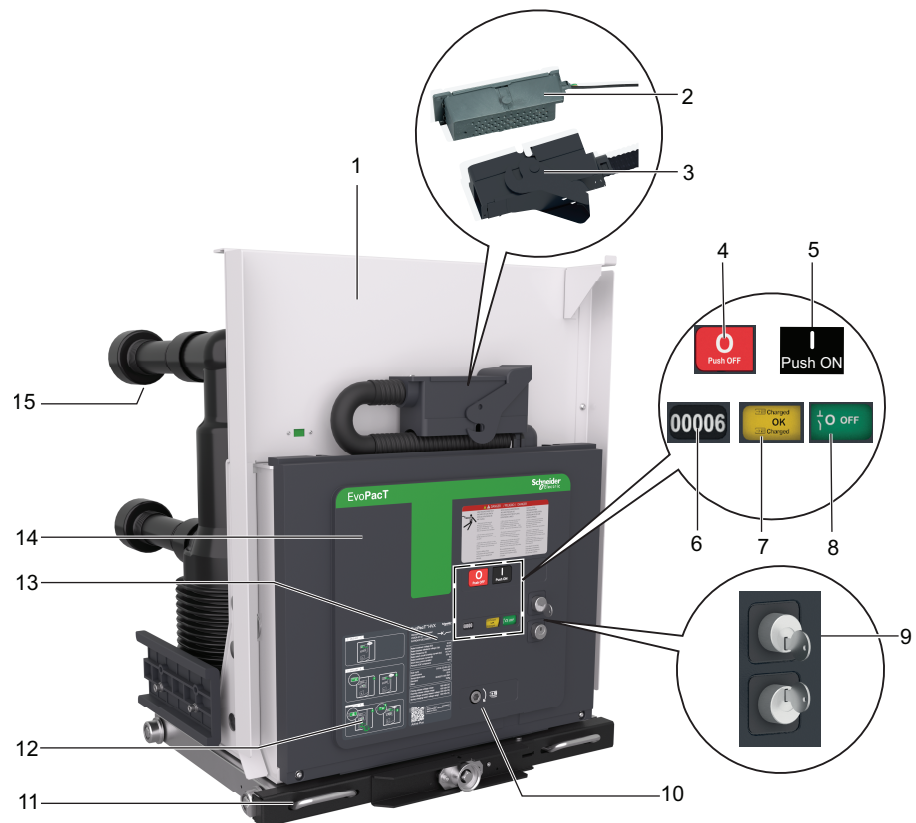

Figure 12
EvoPacT HVX VCB

1	Main front cover	9	Keys
2	LV Connector (cubicle side)	10	Access to spring charge
3	LV Connector (breaker side)	11	Handle
4	Switch OFF push button	12	Label for EvoPacT HVX VCB operating instructions
5	Switch ON push button	13	Rating plate
6	Operation counter	14	Removable top cover
7	Spring charged and ready-to-close indicator	15	Power connections
8	Main contact position indicator		

EvoPacT Metering Truck

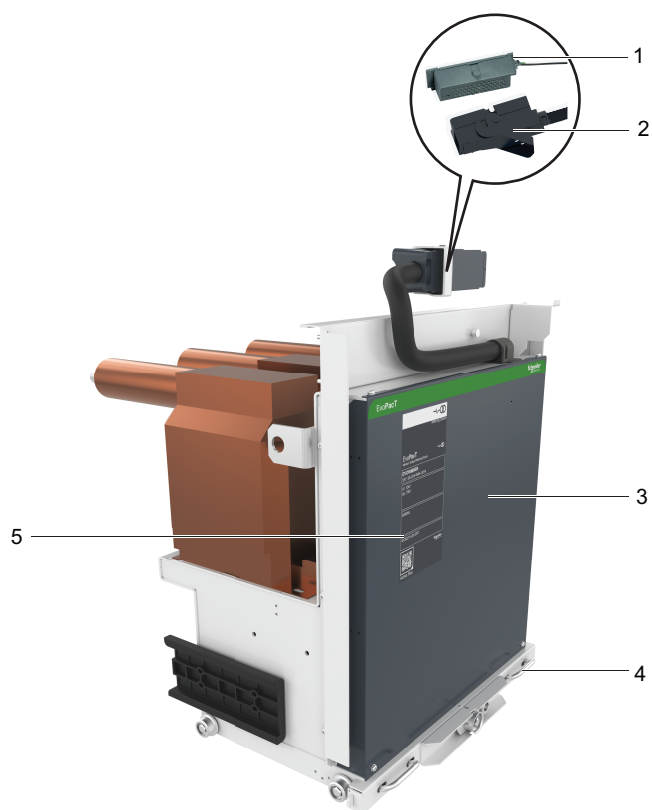

Figure 13
EvoPacT Metering Truck (MTX)

- | | | | |
|---|-----------------------------|---|--------------|
| 1 | LV connector (cubicle side) | 4 | Handle |
| 2 | LV connector (MTX side) | 5 | Rating plate |
| 3 | Main front cover | | |

CVX Contactor

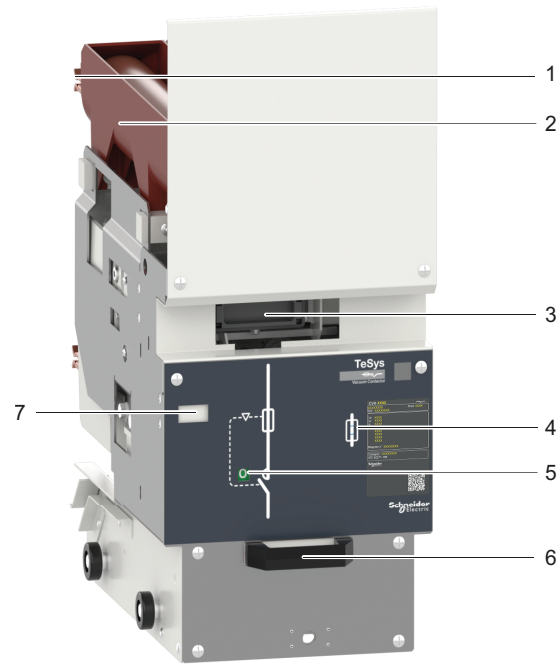

Figure 14
CVX Contactor

- | | | | |
|---|---------------------|---|--------------------|
| 1 | Moving contact | 5 | Position indicator |
| 2 | Fuses | 6 | Handle |
| 3 | LV connector | 7 | Counter |
| 4 | Fuse trip indicator | | |

MCS_eT Cubicle Ratings

Table 7 MCS_eT Cubicle Ratings

Rated voltage		U _r	(kV)	up to 12	17.5	24
Rated insulation level						
Power frequency withstand voltage 50 Hz - 1 min		U _d	(rms kV)	28	38	50
Rated frequency		F _r	(Hz)	50/60	50/60	50/60
Lightning impulse withstand voltage 1.2/50 μs		U _p	(kV peak)	75	95	125
Rated normal current and maximum short time withstand current ⁽¹⁾						
Functional unit with VCB						
Short time withstand current		I _k max.	I _k /t _k (kA/3 s)	up to 40	up to 40	up to 31.5
Rated current	I _r max. busbar	I _r	(A)	up to 4000 ⁽²⁾	up to 4000 ⁽²⁾	up to 3150 ⁽²⁾
Rated current	I _r VCB	I _r	(A)	630	630	630
				1250	1250	1250
				2000	2000	2000
				2500	2500	2500
				3150	3150	3150 ⁽²⁾
				4000 ⁽²⁾	4000 ⁽²⁾	–
Degree of protection						
IP4X						
IP2X						
⁽¹⁾ For functional units equipped with circuit breakers, the breaking capacity is equal to the short time withstand current. In all cases, the device peak making capacity is equal to 2.5 times the short time withstand current for 50 Hz, and 2.6 times the short time withstand current for the 60 Hz. ⁽²⁾ With forced cooling.						

Table 8 Feeder with Contactor Cubicle Ratings

Rated voltage		U_r	(kV)	7.2	12
Rated insulation level					
Power frequency withstand voltage 50 Hz - 1 min		U _d	(rms kV)	20	28
Rated frequency		F _r	(Hz)	50/60	50/60
Lightning impulse withstand voltage 1.2/50 μs		U _p	(kV peak)	60	60 ⁽¹⁾
Rated normal current and maximum short time withstand current					
Functional unit with CVX					
Short time withstand current		I _k max.	I _k /t _k (kA/3 s)	40 ⁽²⁾	40 ⁽²⁾
Rated current	I _r max. busbar	I _r	(A)	up to 4000	up to 4000
Rated current	I _r CVX	I _r	(A)	315	270
Degree of protection					
IP4X ⁽³⁾					
IP2X					
(1) Minimum limit as specified by IEC.					
(2) Limited by fuse.					
(3) IP41 and IP42 options are available.					

Heater

⚠ WARNING
<p>HAZARD OF EQUIPMENT CORROSION</p> <ul style="list-style-type: none"> • Do not alter the location of the heater. • Do not tamper with the heater wires. <p>Failure to follow these instructions can result in death, serious injury, or equipment damage.</p>

NOTICE
<p>HAZARD OF INAPPROPRIATE STORAGE</p> <p>Indoor switchgear units must be stored in a pollution-free indoor environment.</p> <p>Failure to follow these instructions can result in equipment damage.</p>

Each MCSeT cubicle is equipped with two heaters, in the VCB compartment and in the cable compartment respectively. Refer to figure 15.

Energize the heaters to help prevent any moisture formation inside the switchgear units.

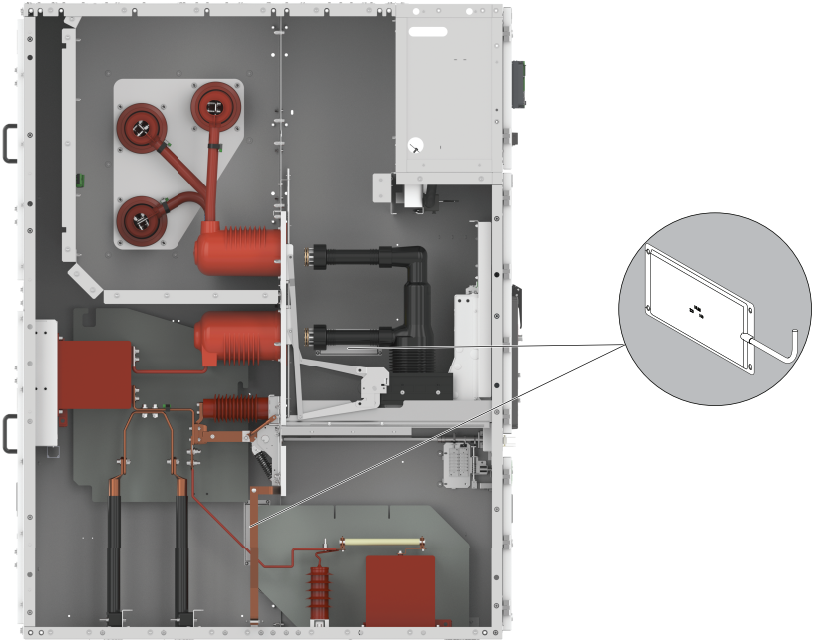

Figure 15
Location of Heater in MCSeT Switchgear

- NOTE:**
- Heaters should be ON and energized for two days before commissioning or putting in service.
 - The images shown here are for illustration purpose only.

VDIS

DANGER

HAZARD OF ELECTRIC SHOCK, EXPLOSION, OR ARC FLASH

- You must use the VDIS unit to detect and indicate the presence or absence of operating voltage.
- You must not use the VDIS unit to distinguish between voltage not present (i.e. $U < 10\%$ of nominal voltage) and dead circuit state (i.e. $U = 0\text{ V}$).

Failure to follow these instructions will result in death or serious injury.

The VDIS unit is a self-powered device.

The VDIS unit is integrated into MCSeT cubicles, flush-mountable and designed according to standard IEC 62271-213. The VDIS unit is fitted with a three LED display and detects the operating voltage presence or absence on the cubicle main circuit.

NOTE: VDIS is not intended to distinguish between voltage not present (that is $U < 10\%$ of nominal voltage) and dead circuit state (that is $U = 0\text{ V}$). The VDIS receives the information through the capacitive sensor installed inside the insulator.

The range of VDIS consists of two versions:

- No voltage output (VO): Voltage presence detection and interface to phase concordance units.
- VO FlairDIN: Voltage presence detection, interface to phase concordance units and VO connection to fault passage indicators.

The VDIS unit has three main functions:

- Visual indication of MV operating voltage presence or absence,
- Phase concordance output,
- VO (VDIS-VO only).

Range of VDIS Unit Variants

For each version of VDIS unit, there are several variants (depending if it includes VO option or not). These variants can be identified as follows:

Table 9 Range of VDIS Unit Variant

VDIS unit variant	Reference
No VO	VDIS006STD
VO FlairDIN	VDIS007STD

Select the variants based on the following criteria:

- The range of MV for the selected product.
- The value of capacitor used inside the bushings of cubicle system.
- The network frequency.
- Associated devices.

Identifying Unit Parts

The VDIS unit consists of two sub-assemblies:

- A protection sub-assembly with open seal.
- An indication sub-assembly.

Keep the wiring set that is currently inserted in the existing unit. Disassembling the existing unit is required to recover the wiring set and assemble it into the new VDIS unit.

Accessing the Test Points of the VDIS

Follow the below steps to access the test points of the VDIS:

NOTE: A small latch (lock) is provided to help prevent the flap from opening accidentally.

1. Gently press the latch (lock) (1) to release the latch.
2. Lift the flap (2) of the VDIS cover.
3. Access the test points.

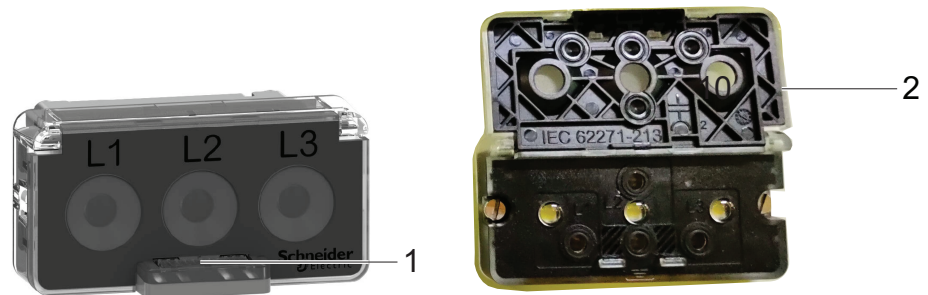

Figure 16
VDIS

- 1 Latch (lock)
- 2 Flap

PowerLogic PD100

The PowerLogic PD100 measures the Partial Discharge (PD) signals broadcast on the MV network through a capacitive coupler. The measurement is performed 24 hours a day, 7 days a week. The PowerLogic PD100 sends relevant data through a wireless communication network to a concentrator.

The PowerLogic PD100 is designed to be installed in the cubicle and connected to all three phases of the MV supply of the cubicle. The PowerLogic PD100 is connected via the same capacitive connection as the one used for the VDIS unit. The PowerLogic PD100 can use the existing capacitive interfaces provided that the capacitive value is between 13 pF to 128 pF.

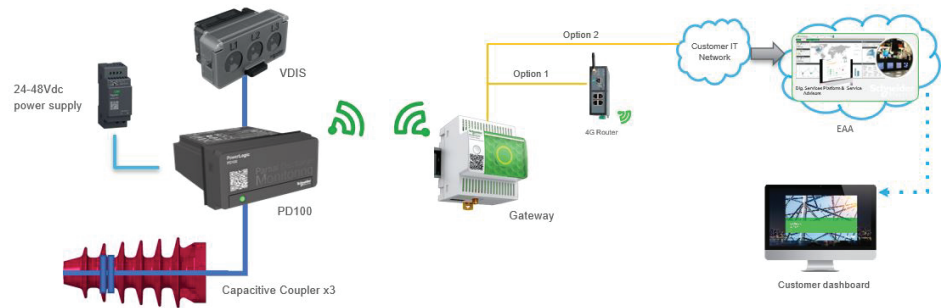

Figure 17
PowerLogic PD100

Accessories

Transport Trolley

▲ WARNING
HAZARD OF INAPPROPRIATE HANDLING
Ensure EvoPacT HVX VCB handling trolley is locked with cubicle before engaging/disengaging EvoPacT HVX VCB from cubicle.
Failure to follow these instructions can result in death, serious injury, or equipment damage.

Mechanical transportation trolleys are available in three configurations for EvoPacT HVX VCB/EvoPacT MTX, based on the cubicle width:

- 650 mm trolley
- 800 mm trolley
- 1000 mm trolley.

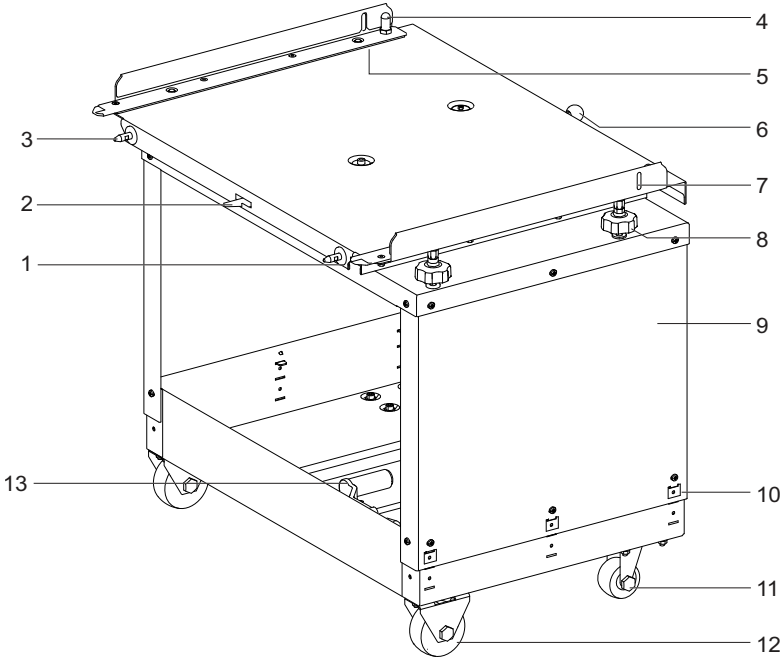
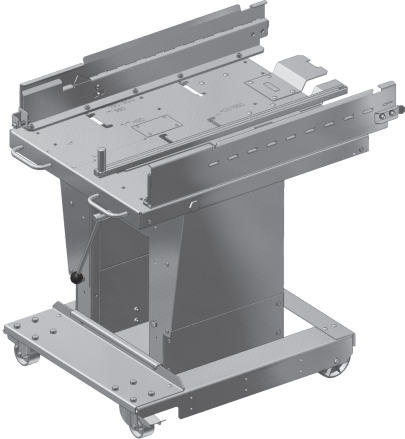



Figure 18
Mechanical Transportation Trolley for the EvoPacT HVX VCB/MTX

- | | | | |
|---|--|----|--|
| 1 | Guiding pins | 8 | Height adjusting wheel |
| 2 | Trolley locking arrangement | 9 | Body of the trolley |
| 3 | Guiding pins | 10 | Height adjustment arrangement at the trolley base. |
| 4 | EvoPacT HVX VCB/MTX stopper on the trolley | 11 | Rear wheel |
| 5 | EvoPacT HVX VCB/MTX rolling plane | 12 | Front wheel |
| 6 | Knob to lock the trolley | 13 | Operation accessories placement in the trolley |
| 7 | Locking the withdrawable part on the trolley | | |

NOTE: The images shown here are for illustration purpose only.

Table 10 Trolley Variants

Rated voltage U_r of the panel (kV)	Panel width (mm)	Trolley	Reference	View
7.2/12	400	CVX Contactor	EIBAE1148-01	
12/17.5	650	EvoPacT HVX VCB/MTX	PG9CBTLY06S3703	
	800	EvoPacT HVX VCB/MTX	PG9CBTLY08S3701	
	1000	EvoPacT HVX VCB/MTX	PG9CBTLY10S3702	
24	800	EvoPacT HVX VCB/MTX	PKR8468001	
	1000	EvoPacT HVX VCB/MTX	PKR84175	
<p>NOTE: The images shown here are for illustration purpose only.</p>				

Operation Accessories

The cubicle may be operated using these accessories.

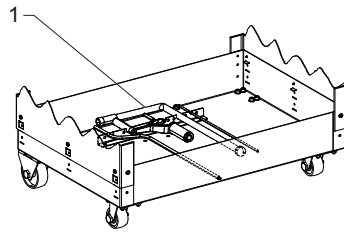





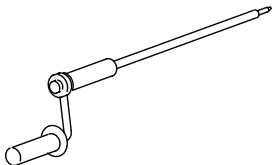



Figure 19
Location of Operation Accessories in the Trolley

- 1 Accessories placed in the trolley

NOTE: For the details of operation accessories supplied together with the MCS eT cubicles, refer to Table 11.

Table 11 List of Operational Accessories

Description	Item no.	Illustration
Double-locking bit key for the cable door and LV compartment door	SEM101137-01	
Manual spring charging handle	AGS H30498-01	
ON/OFF operating rod	AGS H35446-01	
E/S handle	CHD1000063P0005	
Truck handle (rack-in/rack-out)	CHD8000092R0162	
Crank for truck	AGSH31601-01	
Operating lever for earthing switch	AGSC74270-01	

Screw Fastenings

⚠ CAUTION

HAZARD OF INAPPROPRIATE ASSEMBLY

It is recommended to utilize these torque values for the installations that are covered in this guide. Refer to Table 12, page 36.

Failure to follow these instructions can result in injury or equipment damage.

The elastic washers placed on the external sides of the connections and busbars help ensure for distribution of stress induced by the screw torque.

Table 12 Recommended Tightening Torques for Screw Connection

Threads	Plastics	Threaded welding pin	Insert nut for insulation	Main circuit	Secondary connection	General connection
M3	0.1	–	–	–	0.7	1.1
M4	0.25	–	–	–	1.5	2.6
M5	0.5	–	3.5	–	2.5	5.0
M6	0.8	6.5	6.5	6.5	3.5	8.8
M8	1.8	15.0	15.0	17.0	–	21.0
M10	3.5	27.0	32.0	35.0	–	42.0
M12	6.0	–	45.0	68.0	–	70.0
M16	12.0	–	110.0	135.0	–	170.0
M20	–	–	220.0	–	–	330.0

The main circuit includes the below fastenings:

- Copper busbar connections and fastening bolts.
- Cable fastening bolts.
- Fastening bolts for contact.
- E/S and load-break switch, bolts for connection with the busbar.
- For CT and VT torque values, refer to the instruction sheet.

Auxiliary Products

▲ WARNING

HAZARD OF INAPPROPRIATE OPERATION

Comply with the manufacturer safety data sheets for the auxiliary products.

Failure to follow these instructions can result in death, serious injury, or equipment damage.

Table 13 Auxiliary Products

Auxiliary product	Order number
Cleaning agent	S008152
Lubricant KL, 0.5 kg can	ST312-111-835
Liquid lubricant FL, 0.5 kg can	S008153
Repair paint, 500 g can, RAL9003, silk-grey	S009 492

NOTE: The auxiliary products are provided by the manufacturer. The use of alternative auxiliary products is not permissible.

Interlocks

The MCSeT switchgear has two types of interlocks:

- Mechanical interlocks.
- Electromagnetic interlocks (optional).

⚠ WARNING

HAZARD OF INAPPROPRIATE OPERATION

- Installation, repair and maintenance work on the EvoPacT HVX VCB must only be carried out by qualified and certified personnel.
- Ensure to comply with the operation procedures and the interlock mechanism is operated effectively. Refer to Operations, page 47 and Interlocks, page 38.

Failure to follow these instructions can result in death, serious injury, or equipment damage.

The mechanical interlocks are the primary interlocks, which is supported by an additional electrical interlock function to achieve the switchgear cubicle safeguard interlock function.

EvoPacT racking device has a robust interlocking system with:

- Switchgear door
- LV plug
- VCB
- E/S.

Mechanical Interlocks

Table 14 Functions and Method of Operation of Mechanical Interlocks

Interlocks	Function of interlock	Method of operation
LV plug interlock	LV plug cannot be removed when the EvoPacT HVX VCB is in the service condition.	The EvoPacT HVX VCB will activate and deactivate the interlock once the rack-in operation initiates.
Interchangeability interlock	The VCB other than EvoPacT HVX VCB cannot be inserted in the cubicle.	LV plug Pin code mismatches with other rating VCB.
E/S handle interlock	The E/S handle cannot be inserted when the cable compartment door is open.	The plunger on the interlock is pushed by the cable compartment door, access to the operating mechanism is closed. Refer to Figure 20.
Between EvoPacT HVX VCB	The EvoPacT HVX VCB cannot be racked-in when the E/S is ON.	The interlock lever blocks the truck from carrying out the rack-in/rack-out operations. Refer to Figure 21.
	The E/S cannot be switched on, if EvoPacT HVX VCB truck is in service position.	
Between the cable compartment door and E/S	The cable compartment door cannot be opened when the E/S is OFF.	The E/S mechanism rotation activates the interlock in the cable compartment. Refer to Figure 22 and Figure 23.
	The cable compartment door can be opened when the E/S is ON.	
Between EvoPacT HVX VCB door and VCB truck	The EvoPacT HVX VCB cannot be racked-in when the VCB door is open.	The lever from EvoPacT HVX VCB truck gets engaged with the locking bracket on the VCB compartment front door. Refer to Figure 24.
	The EvoPacT HVX VCB can be racked-in when the VCB door is closed.	

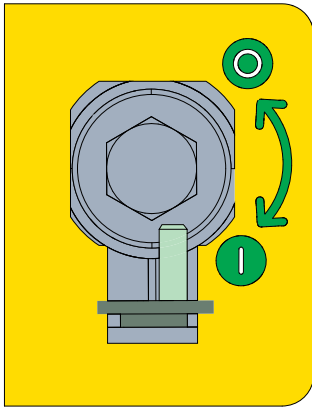

Figure 20
E/S Handle Interlock

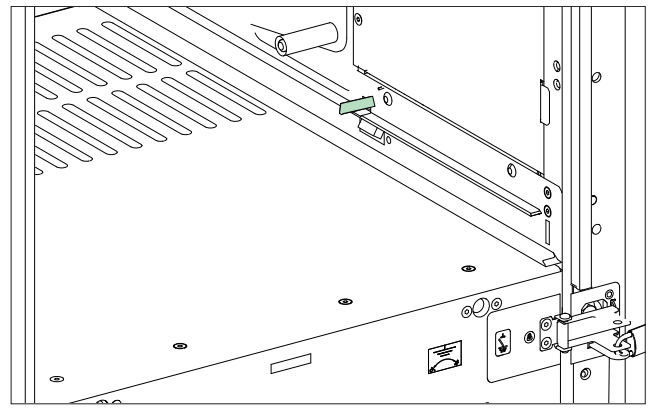

Figure 21
EvoPacT HVX VCB Truck and the E/S Interlock

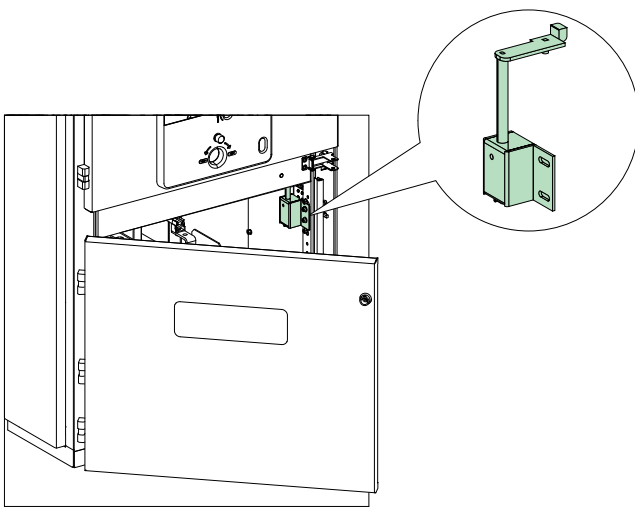

Figure 22
Cable Compartment Door and E/S Interlock, 12/17.5 kV

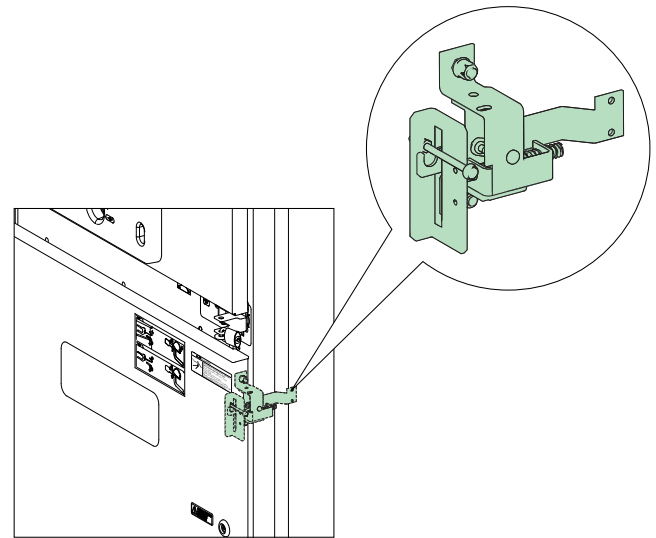

Figure 23
Cable Compartment Door and E/S Interlock, 24 kV

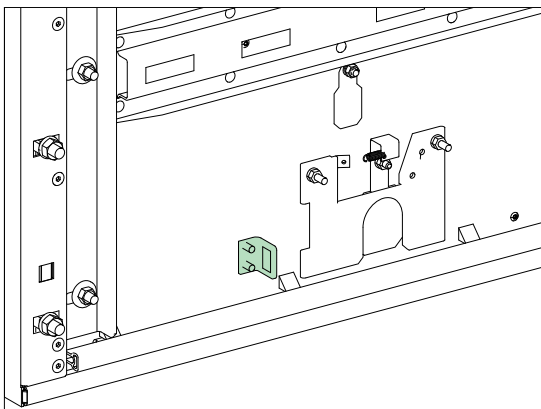

Figure 24
EvoPacT HVX VCB Door and VCB Truck Interlock

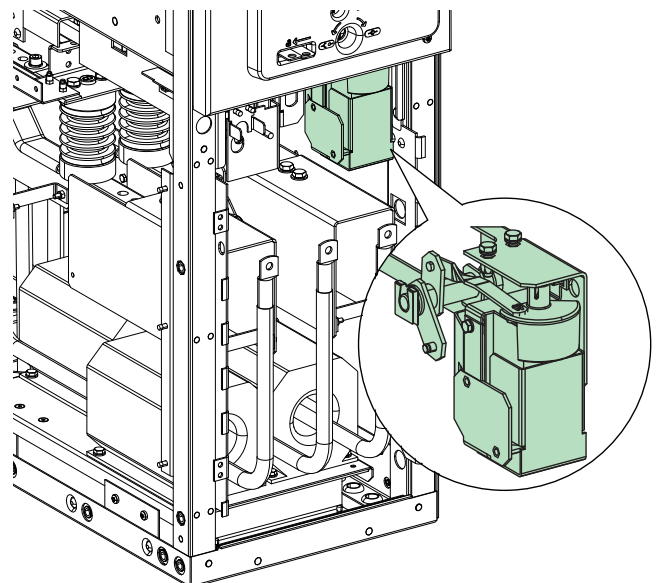

Figure 25
Feeder with Contactor Cubicle Cable Compartment Door interlock

Electromagnetic Interlocks (Optional)

⚠ WARNING

HAZARD OF INAPPROPRIATE OPERATION

Ensure that the switchgear interlocking is complete.

Failure to follow these instructions can result in death, serious injury, or equipment damage.

Electromagnetic blocking coils can be used for inter-panel as well as intra-panel interlocks:

- The EvoPacT HVX VCB ON and OFF pushbuttons are blocked.
- Manual actuation of the E/S is blocked.

NOTE:

- In case of failure of the supply voltage, all electrical interlocks are in the **locked** position. Measure: Re-establish supply voltage.
- Note the purchase contract and the switchgear specific circuit diagram as regards the design of the interlocking systematics.

Padlocks

⚡⚠ DANGER

HAZARD OF ELECTRIC SHOCK, EXPLOSION OR ARC FLASH

- Ensure terminals are not live before opening the shutter.
- Padlock the shutter in close condition while performing maintenance.
- Remove shutter padlock while racking VCB to service position.

Failure to follow these instructions will result in death or serious injury.

The holes are provided for padlock yokes of \varnothing 8 mm.

NOTE: All the padlocks are not included in the scope of supply.

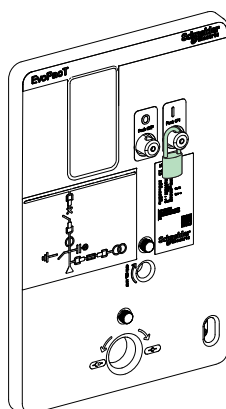

Figure 26
Manual Switching ON of Circuit Breaker Locked by Padlock

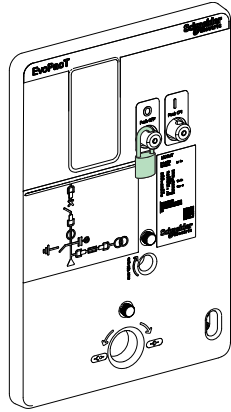

Figure 27
Manual Switching OFF of Circuit Breaker Locked by Padlock

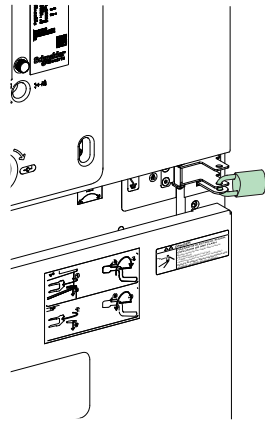

Figure 28
Mechanical Lock-out of Earthing Switch by Padlock

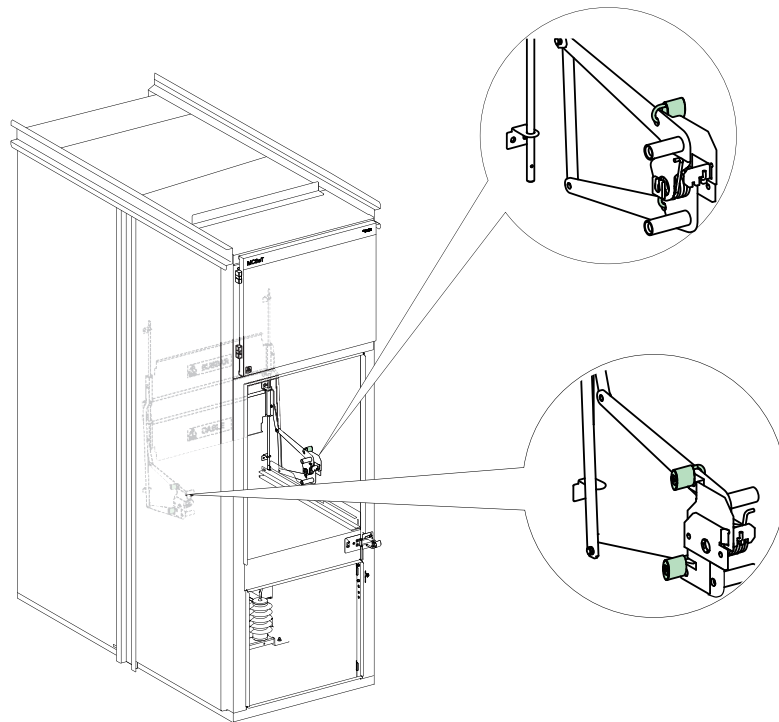

Figure 29
Padlock for the Shutter

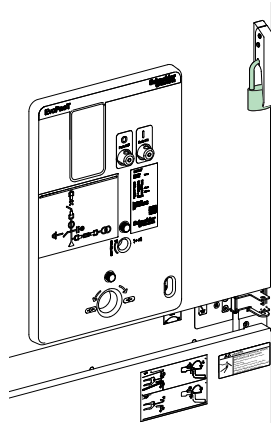

Figure 30
Padlock for the Handle

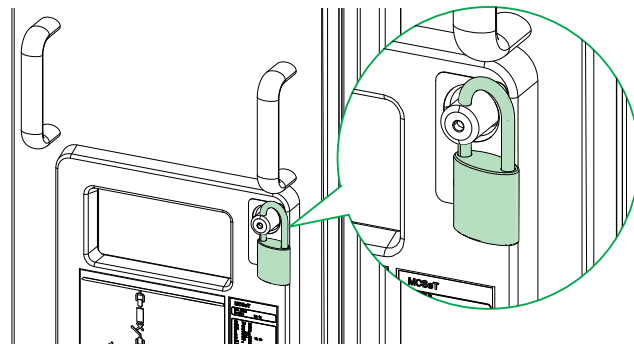

Figure 31
Manual Switching OFF of Contactor Locked by Padlock

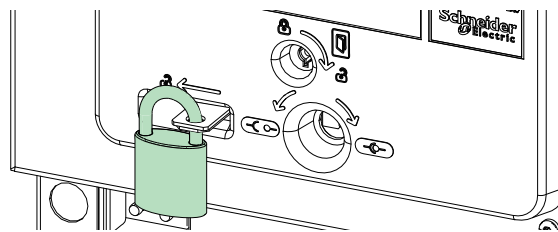

Figure 32
Padlock on Truck - Manual Insertion of Contactor Truck Blocked by Padlock

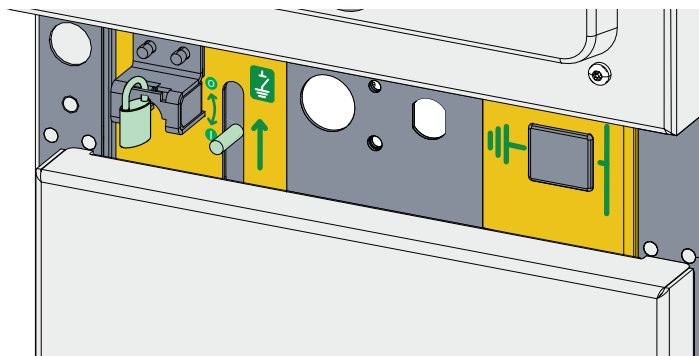

Figure 33
Contactor Cubicle - Mechanical Lock-out of Earthing Switch by Padlock

Keylocks

Circuit Breaker Position Keylocks

The function of the keylocks is to lock and unlock the circuit breaker plug in the test position.

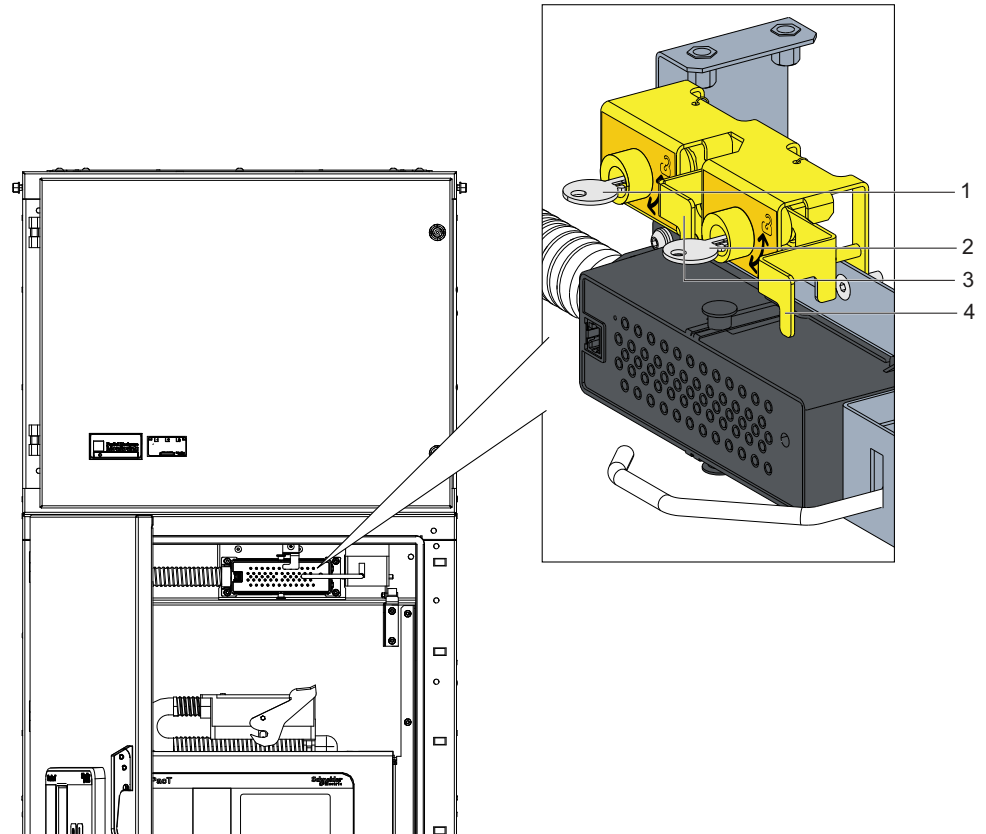

Figure 34
Circuit Breaker Keylocks

- | | | | |
|---|-----------|---|------------------------|
| 1 | Keylock 1 | 3 | Plug locking bracket 1 |
| 2 | Keylock 2 | 4 | Plug locking bracket 2 |

Follow the below steps to lock and unlock the circuit breaker keylocks:

Locking the Circuit Breaker:

1. Check keys (1) and (2) are inserted in their respective key slots.
2. Turn the keys (1) and (2) clockwise to the lock position.
3. Check the circuit breaker plug locking brackets (3) and (4) are blocking the circuit breaker plug.
4. Remove the keys (1) and (2) from the key slots.

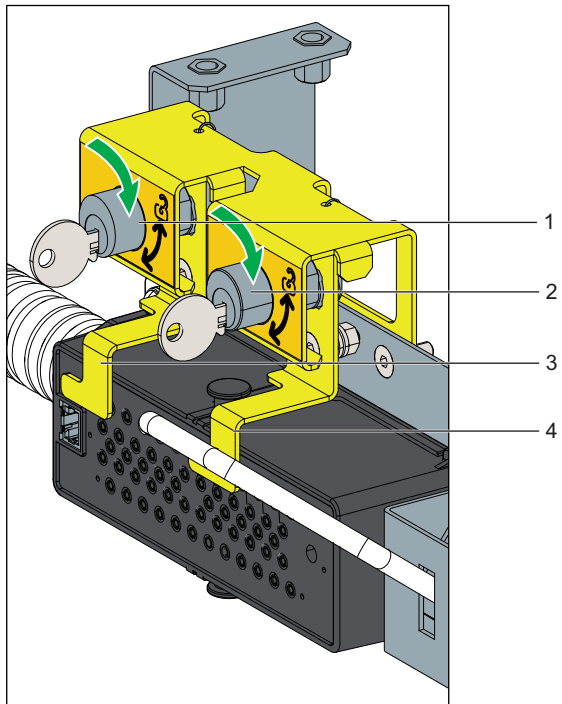

Figure 35
Block the Access to the Circuit Breaker

- | | | | |
|---|-----------|---|------------------------|
| 1 | Keylock 1 | 3 | Plug locking bracket 1 |
| 2 | Keylock 2 | 4 | Plug locking bracket 2 |

Unlocking the Circuit Breaker:

1. Insert the keys (1) and (2) into their respective key slots.
2. Turn the keys (1) and (2) counter-clockwise to the unlocked position.
3. Check the circuit breaker plug locking brackets (3) and (4) are released from the circuit breaker plug.

NOTE: The keys (1) and (2) can not be removed in the unlocked position.

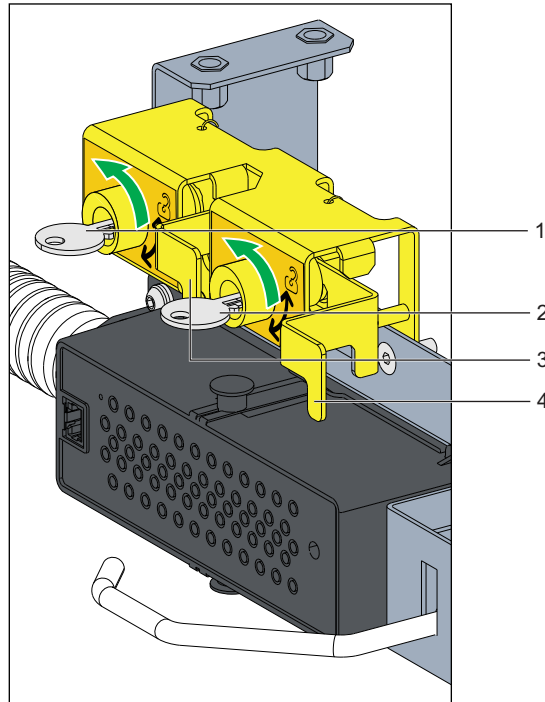

Figure 36
Access to the Circuit Breaker Plug

- | | | | |
|---|-----------|---|------------------------|
| 1 | Keylock 1 | 3 | Plug locking bracket 1 |
| 2 | Keylock 2 | 4 | Plug locking bracket 2 |

E/S Keylock in OFF Position

Initial Situations:

Check the key is available in the key slot, and make sure it is in the unlock position.

NOTE: The slider can be moved up and down, when the key is in the unlock position.

1. Lift the slider up and block the access to insert the E/S handle.
2. Turn the key clockwise to the lock position.

3. Check the lock open flap slides out and engages with slider.
 - The slider can not be move down to block the access to E/S handle insertion.
 - Remove the key from the key slot.

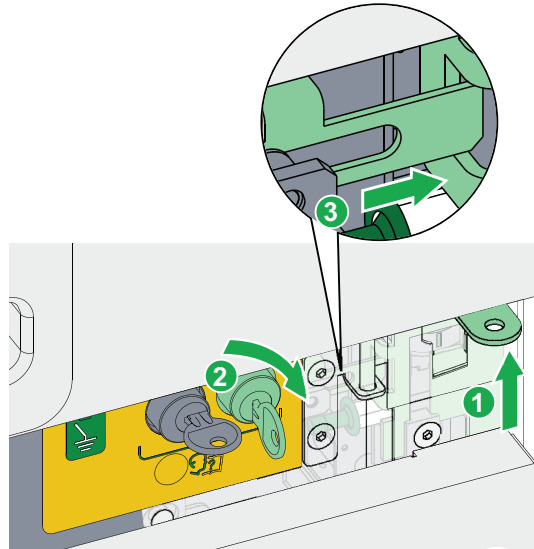

Figure 37
E/S Handle Insertion in OFF Position

E/S Keylock in ON Position

Follow the below steps to block the access to E/S handle insertion:

1. Check the key (1) is inserted in the key slot.
2. Turn the key (1) clockwise to the lock position.
3. Check the lock close flap (2) slides out and blocks the access to insert the E/S handle.
4. Remove the key (1) from the key slot.

NOTE: The key (1) can be removed only in the locked position.

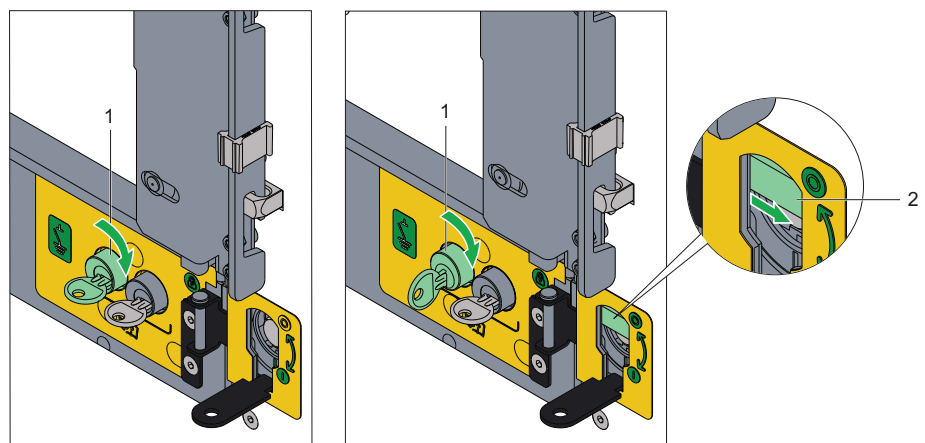

Figure 38
E/S Handle Insertion in ON Position

- 1 Keylock 1
- 2 Lock close flap

Operations

⚠️⚠️ DANGER

HAZARD OF ELECTRIC SHOCK, EXPLOSION OR ARC FLASH

- Maintenance work must only be performed by trained electricians with proven experience of the MCSeT and all the relevant safety standards.
- Comply with the operating sequences. Refer to Operations, page 47.
- Perform every switching operation completely.
- Ensure the presence of voltage in the system
- After each switching operation that involves the use of a crank, lever, or handle, take out the tool and place it back in the transport trolley. Refer to Operation Accessories, page 35.

Failure to follow these instructions will result in death or serious injury.

Operating the VCB

VCB Controls and Indicators









⚠️⚠️ DANGER

HAZARD OF ELECTRIC SHOCK, EXPLOSION, OR BURN

- Installation, repair, and maintenance work on the EvoPacT HVX VCB must only be carried out by qualified and certified personnel.
- Beware of potential danger, apply appropriate PPE.
- Follow safe electrical work practices.

Failure to follow these instructions will result in death or serious injury.

Table 15 Position Indicator

Item	Energy-storing device (spring mechanism)		VCB ON/OFF		Possible operating sequence
1		Released		OFF	None
2		Charged		OFF	C-O
3		Released		ON	O
4		Charged		ON	O-C-O
C = Switching ON (Closing) O = Switching OFF (Opening)					

Charging the VCB Energy Storing Device

Initial Position:

- VCB: OFF
- Energy storing device: Released

Motorized Charging

The energy-storing device automatically charges upon the application of the motor supply voltage.

The position indicator of the energy-storing device indicates the charged condition (4). Refer to Figure 39.

Manual Charging

Follow the below steps to charge the VCB:

1. Rotate the knob (1) counter-clockwise to access the manual charging of the gear box (2). Refer to Figure 39.
2. Insert the crank handle (3) into the guide (2).
3. Turn the crank handle (3) clockwise, until complete charging of the mechanism.

NOTE: Ensure that the direction indicator (4) shows that it is in charged condition.

4. Remove and place the crank handle (3) back into the transport trolley.

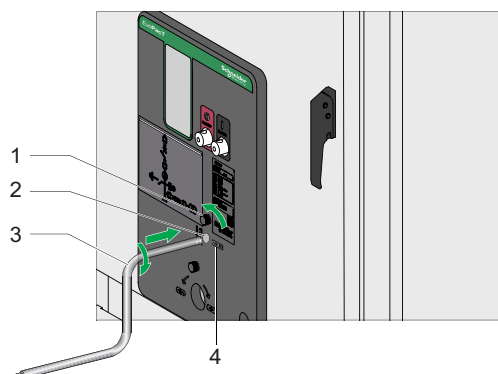

Figure 39
Manual Charging of EvoPacT HVX VCB

- | | | | |
|---|-------|---|-------------------------------|
| 1 | Knob | 3 | Crank handle |
| 2 | Guide | 4 | Direction indicator (charged) |

Switching the VCB Electrically

Switching ON (Closing)

Actuate closing release via bay computer or remote control.

The energy storing device can be charged immediately after switching ON (either by hand or by motor). If voltage is applied to the motor, charging is performed automatically.

Switching OFF (Opening)

- Actuate the opening release via the bay computer or the remote control
- By undervoltage release or
- By secondary release

Switching the VCB Manually

Switching ON via the Push Rod

The closed-door operation of the EvoPacT HVX VCB involves switching the VCB to the connected/service position or rack-in position.

Follow the below steps to switch ON VCB via push rod:

1. Take the push rod (1) from the transport trolley. Refer to Figure 40.
2. Insert the push rod (1) through switch ON guide (2) of the VCB front door.
3. Push the switch ON button with the push rod (1).

⚠ WARNING

HAZARD OF INAPPROPRIATE OPERATION

Ensure that the VCB is switched ON via push rod and the position indicator indicates ON.

Failure to follow these instructions can result in death, serious injury, or equipment damage.

4. Remove the push rod from the switch ON guide (2) of VCB door.
5. Place the push rod (1) back into the transport trolley.

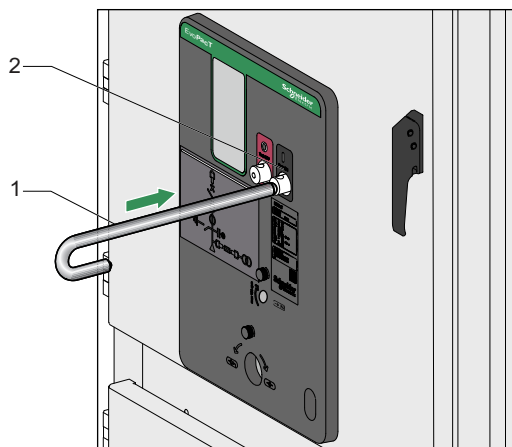

Figure 40
Switching ON the EvoPacT HVX VCB via Push Rod

- 1 Push rod
- 2 Switch ON guide

The energy-storing device can be charged again immediately after switching ON either by hand or by motor. If supply voltage is present, the energy-storing device is charged automatically.

Switching OFF via the Push Rod

Follow the below steps to switch OFF VCB via push rod:

1. Take the push rod (1) from the transport trolley. Refer to Figure 41.
2. Insert the push rod (1) through switch OFF guide (2) of the VCB front door.
3. Push the switch OFF button with the push rod (1).

⚠ WARNING

HAZARD OF INAPPROPRIATE OPERATION

Ensure that the VCB is switched OFF via push rod and the position indicator indicates OFF.

Failure to follow these instructions can result in death, serious injury, or equipment damage.

4. Remove the push rod from the switch OFF guide (2) of VCB door.
5. Place the push rod (1) back into the transport trolley.

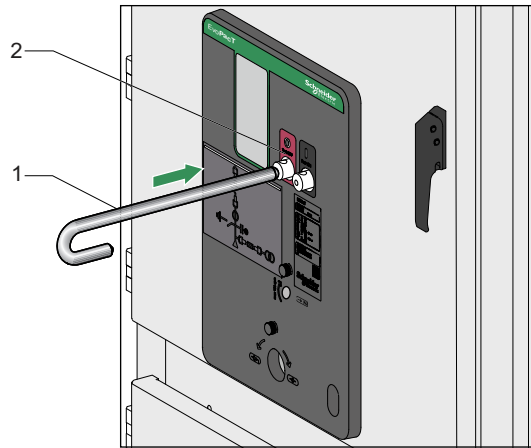

Figure 41
Switching OFF the EvoPacT HVX VCB via Push Rod

- 1 Push rod
- 2 Switch OFF guide

Operating the CVX Contactor

Switching OFF via the Push Rod

Follow the below steps to switch OFF the CVX contactor via push rod:

1. Take the push rod (2) from the transport trolley. Refer to Figure 42.
2. Insert the push rod (2) through switch OFF guide (1) of the CVX contactor cubicle front door.
3. Push the switch OFF button with the push rod (2).

⚠ WARNING

HAZARD OF INAPPROPRIATE OPERATION

Ensure that the CVX contactor is switched OFF via push rod, and the position indicator indicates OFF.

Failure to follow these instructions can result in death, serious injury, or equipment damage.

4. Remove the push rod from the switch OFF guide (1) of CVX contactor cubicle door.
5. Place the push rod (2) back into the transport trolley.

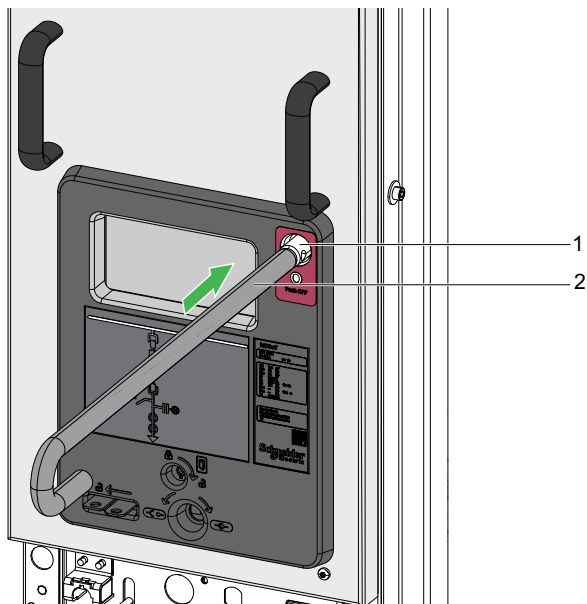

Figure 42
Switching OFF the CVX Contactor via Push Rod

- 1 Switch OFF guide
- 2 Push rod

Move the Truck into Service Position or Disconnected Position

The truck can only be moved into connected/service or disconnected/test position when de-energized.

DANGER

HAZARD OF ELECTRIC SHOCK, EXPLOSION OR ARC FLASH

- Switch OFF the EvoPacT HVX VCB or, in the case of isolate the feeder.
- Do not pull the crank out before the EvoPacT HVX VCB has reached its end position.
- Do not pull the crank out in an undefined intermediate position.

Failure to follow these instructions will result in death or serious injury.

Initial Situation:

- VCB OFF
- E/S OFF

Rack-in the truck from Disconnected Position into Service Position

Follow the below steps to rack-in the truck from disconnected/test position into connected/service position:

1. Rotate knob (1) counter-clockwise and hold it until the flap provides access to the guide. Refer to the Figure 43.
2. Insert truck handle (3) through the opening guide in the door onto the drive shaft of the VCB truck.
3. Turn the truck handle (3) clockwise until the truck is racked-in.
4. Remove the truck handle (3) and place it back into the transport trolley.
5. Check the position of the truck through the inspection glass (4).

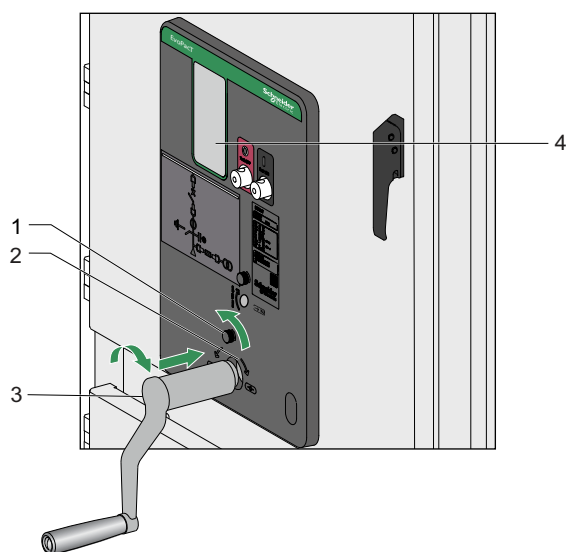

Figure 43
Racking-in the Truck via Truck Handle

- | | | | |
|---|---------------|---|------------------|
| 1 | Rotatory Knob | 3 | Handle |
| 2 | Indicator | 4 | Inspection glass |

NOTE: During the rack-in/rack-out, the door gets locked to help prevent it from opening. The door can be unlocked only if the truck is in the disconnected/test position.

Rack-out the Truck from Service Position into Disconnected Position

Follow the below steps to rack-out the truck from connected/service position to disconnected/test position:

1. Rotate knob (1) counterclockwise and hold it until the flap provides access to the guide. Refer to the Figure 44.
2. Insert truck handle (3) through the opening guide in the door onto the drive shaft of the VCB truck.
3. Turn truck handle (3) counter-clockwise until the truck is racked-out.
4. Remove and place the truck handle (3) back into the transport trolley.
5. Check the position of the truck through the inspection glass (4).

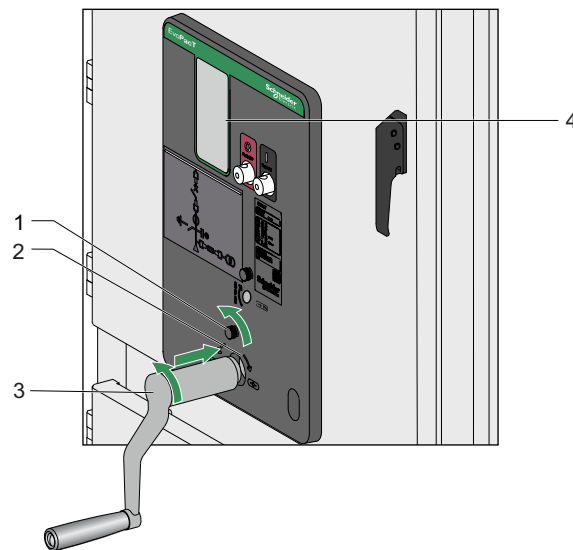

Figure 44
Racking-out the Truck via Truck Handle

- | | | | |
|---|---------------|---|------------------|
| 1 | Rotatory Knob | 3 | Handle |
| 2 | Indicator | 4 | Inspection glass |

NOTE: During the rack-in/rack-out, the door gets locked to help prevent it from opening. The door can be unlocked only if the truck is in the disconnected/test position.

Switching the E/S Manually

Initial Situation:

- VCB: OFF
- Truck: In disconnected position

Switching ON the E/S

Follow the below steps to switch ON the E/S:

1. Press the slider (2) downwards until access for the E/S operation is available. Refer to the Figure 45.
2. Insert E/S handle (1) aligned with axis point.
3. Turn the E/S handle (1) clockwise by 180°.
4. Check the E/S position indicator through cable compartment inspection window and make sure that the E/S is ON.
5. Remove the E/S handle (1) and place it back into the transport trolley.

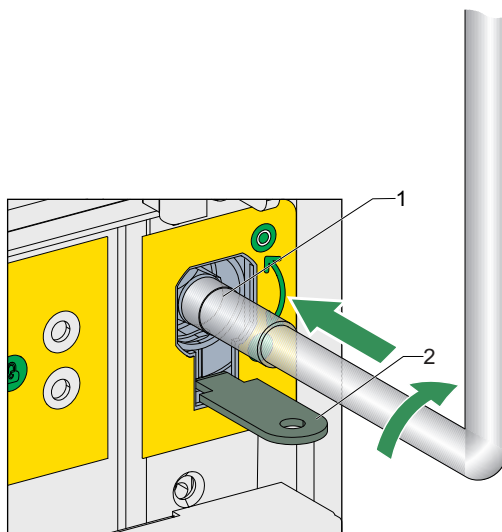

Figure 45
Switching E/S ON

- 1 Handle
- 2 Slider

Switching OFF the E/S

Follow the below steps to switch OFF the E/S:

1. Press the slider (2) downwards until access to the E/S operation is available.
2. Insert E/S handle (1) aligned with axis point.
3. Turn the E/S handle (1) counter-clockwise by 180°.
4. Check the E/S position indicator through cable compartment inspection window and make sure that the E/S is OFF.
5. Remove the E/S handle (1) and place it back into the transport trolley.

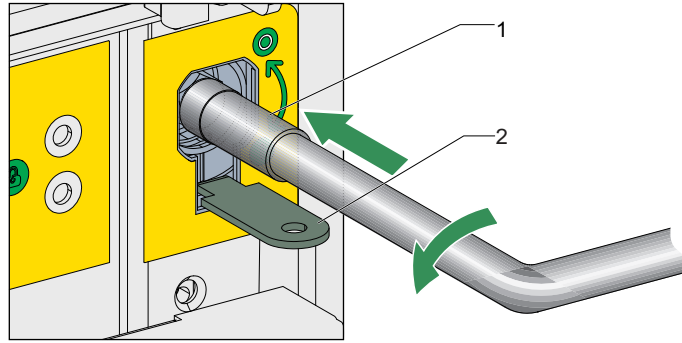

Figure 46
Switching E/S OFF

- 1 Handle
- 2 Slider

Switching the Contactor Cubicle E/S Manually

Initial Situation:

- CVX contactor: OFF
- Truck: In disconnected position

Switching ON the Contactor Cubicle E/S

Follow the below steps to switch ON the contactor cubicle E/S:

1. Push the slider (2) upwards and insert the handle (1) to the E/S with the handle rod pointing up. Refer to the Figure 47.
2. Turn the E/S handle (1) clockwise by approximately 95°.
3. Check position indicator (3). Make sure that the E/S is ON.
4. Remove the E/S handle (1), and place it back into the transport trolley.

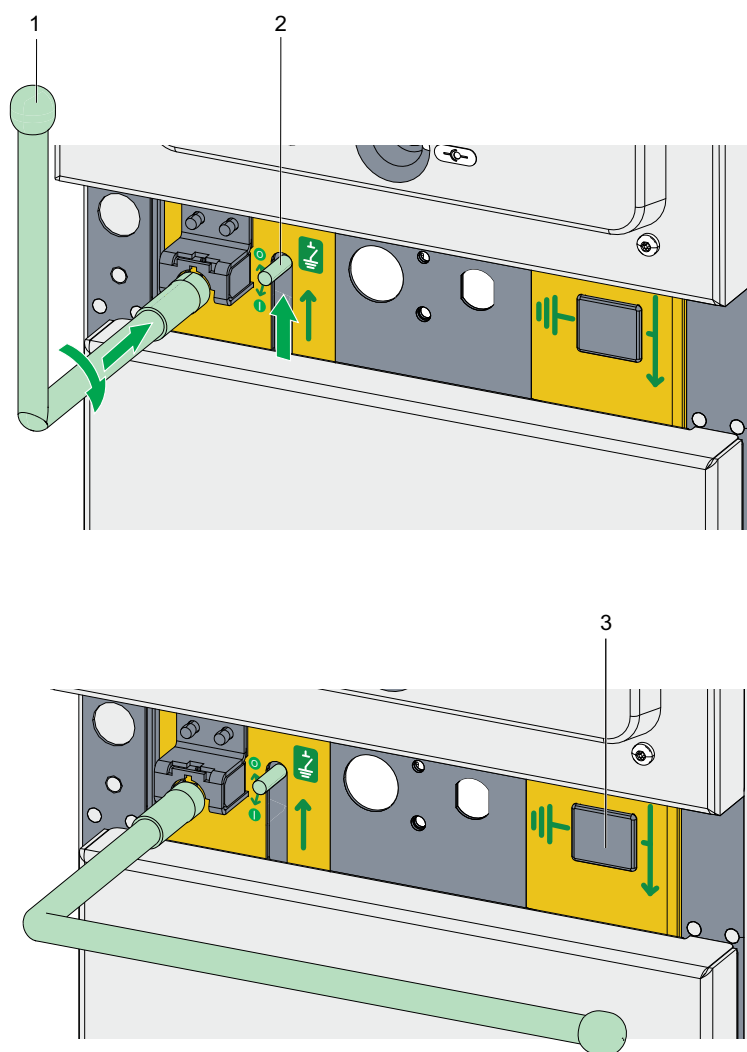

Figure 47
Switching E/S ON

- | | | | |
|---|--------|---|--------------------|
| 1 | Handle | 3 | Position indicator |
| 2 | Slider | | |

Switching OFF the Contactor Cubicle E/S

Follow the below steps to switch ON the contactor cubicle E/S:

1. Push the slider (2) upwards and insert the handle (1) to the E/S with the handle rod pointing to the right. Refer to the Figure 48.
2. Turn the E/S handle (1) counter-clockwise by approximately 95°.
3. Check position indicator (3). Make sure that the E/S is OFF.
4. Remove the E/S handle (1) and place it back into the transport trolley.

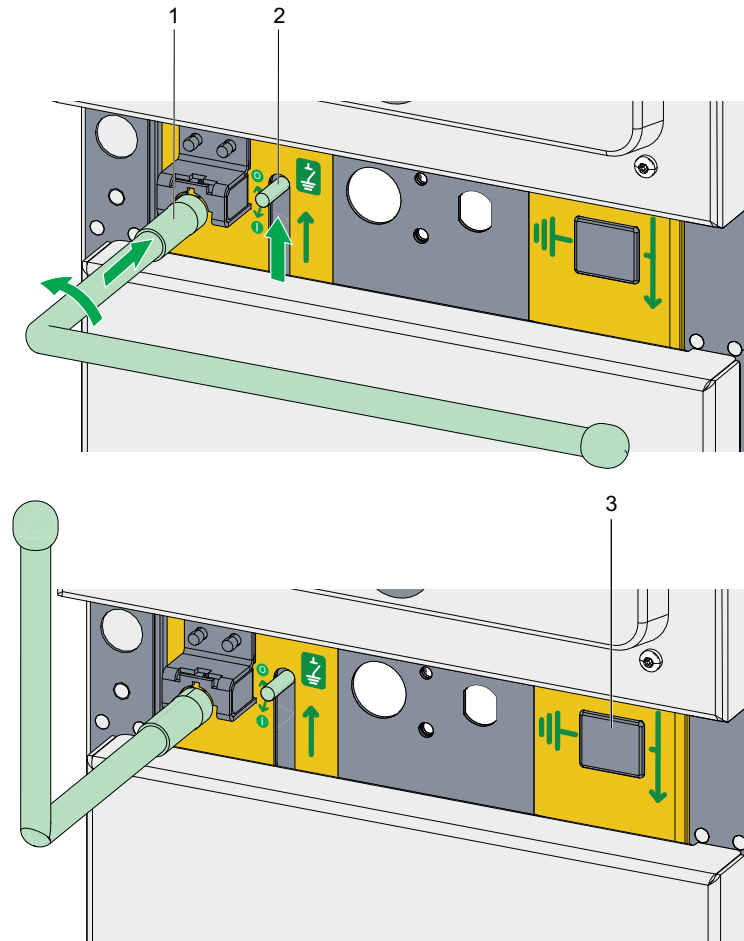

Figure 48
Switching E/S OFF

- | | | | |
|---|--------|---|--------------------|
| 1 | Handle | 3 | Position indicator |
| 2 | Slider | | |

Standard Switching Operations

Switching a Feeder

Initial Situation:

- VCB: OFF
- EvoPacT HVX VCB truck: In disconnected/test position
- E/S: OFF

Switch Feeder Cable ON

Follow the below steps to switch feeder cable ON:

1. Move truck the into connected/service position (1).
2. Switch ON the VCB (2).

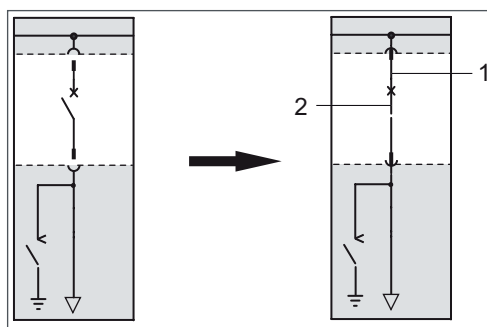

Figure 49
Switch Feeder Cable ON

Switch Feeder Cable OFF

Follow the below steps to switch feeder cable OFF:

1. Switch OFF the VCB.
2. Move truck the into disconnected/test position.

Earthing the Feeder Cable

Initial Situation:

- VCB: OFF
- EvoPacT HVX truck: In disconnected/test position
- E/S: OFF

Earthing Feeder Cable

1. Check the feeder is de-energized.
2. Switch ON the E/S (1).

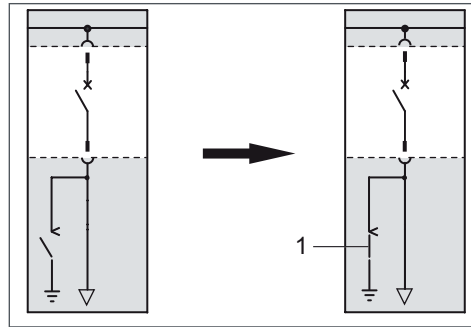

Figure 50
Earthing Feeder Cable

De-earthing

Switch OFF the E/S.

Coupling Busbar Sections via BSC

With EvoPacT HVX Truck

Initial Situation:

- VCB: OFF
- EvoPacT HVX truck: In disconnected/test position
- E/S: OFF

Coupling the Sections

Follow the steps for coupling the sections:

1. Move trucks into the connected/service position (1).
2. Switch ON the VCB (2).

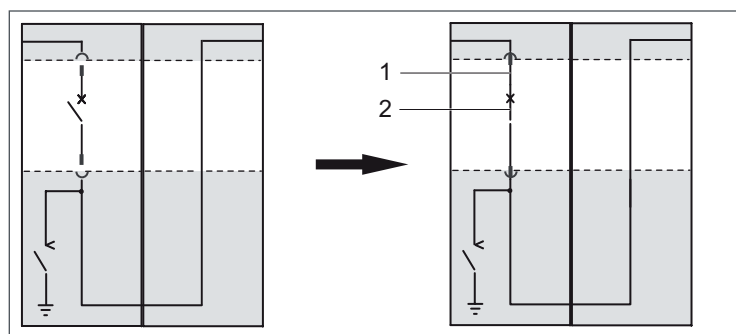

Figure 51
Coupling Busbar Sections via BSC and EvoPacT HVX Trucks

Uncoupling

Follow the steps for uncoupling the sections:

1. Switch OFF the VCB.
2. Move trucks into disconnected/test position.

Earthing the Busbar

⚡⚠ DANGER

HAZARD OF ELECTRIC SHOCK, EXPLOSION, OR ARC FLASH

- Trucks (EvoPacT HVX VCB and EvoPact MTX) in the appropriate busbar sections must be in the disconnected position.
- Observe the conditions of Operations, page 47 and Interlocks, page 38.

Failure to follow these instructions will result in death or serious injury.

Earthing the Busbar with Busbar E/S in the Metering Panel

Initial situation:

- E/S : OFF
- Metering truck EvoPact MTX: in service position

Earthing the busbar

Switch ON the E/S (1).

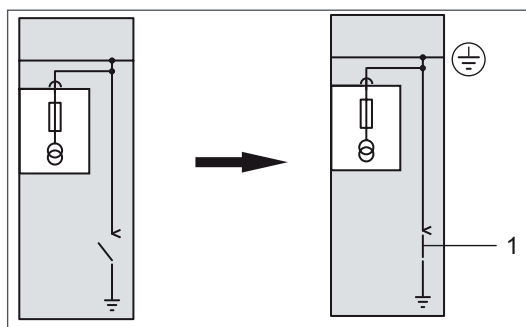

Figure 52

Earthing the Busbar with Busbar E/S in the Metering Panel

De-earthing

Switch OFF the E/S.

Access to the MCSeT Cubicle Compartments

⚠️ ⚠️ DANGER

HAZARD OF ELECTRIC SHOCK, EXPLOSION, OR ARC FLASH

- Make sure that the truck is in disconnected/test position before opening the front door.
- Turn off all power supply or de-energize the complete cubicle because opening any door is not allowed if the busbar or cable is live.

Failure to follow these instructions will result in death or serious injury.

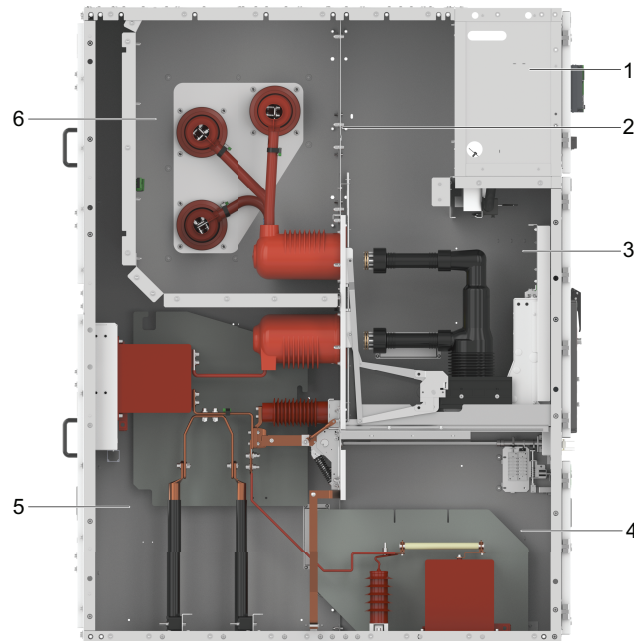

Figure 53
Access to the Main Circuit Compartments of I/F Cubicle

- | | | | |
|---|--|---|---------------------------------------|
| 1 | Access to the LV compartment | 4 | Front access to the cable compartment |
| 2 | Front access to the busbar compartment | 5 | Rear access to the cable compartment |
| 3 | Access to the VCB compartment | 6 | Rear access to the busbar compartment |

NOTE: The image shown here are for illustration purpose only.

Access to the Cable Compartment

⚡ ⚠ DANGER

HAZARD OF ELECTRIC SHOCK, EXPLOSION OR ARC FLASH

Before accessing the cable compartment, ensure the following:

- E/S is ON.
- EvoPacT HVX VCB is OFF and in disconnected/test condition.
- Check the VDIS indication for zero voltage across the cubicle.

Failure to follow these instructions will result in death or serious injury.

Access to the Cable Compartment from Front Side

To access the cable compartment from front side (AFL):

Opening of Cable Compartment Door

To open the cable compartment door:

1. Release the securing bolts (2) on the cable compartment (1) with standard double-bit key. Refer to Figure 54.
2. Swing the cable compartment door (3) to open it.
3. The cable compartment is now accessible from the front.

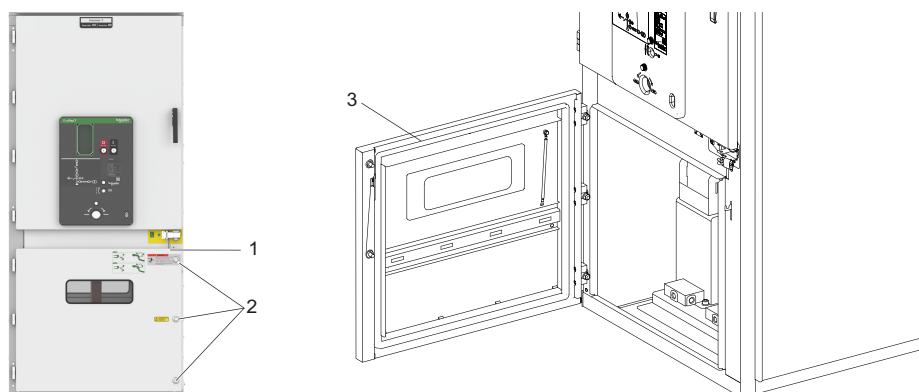

Figure 54
Access to Cable Compartment

- 1 Cable compartment
- 2 Securing bolts
- 3 Cable compartment door

Removal of Fuse, VT, and Surge Arrester from 12/17.5 kV Cubicle

Removal of Fuse

1. Press the fuse lock (1) , and pull the fuse (2) upwards.
2. Remove the fuse (2). Refer to Figure 55.

NOTE: Follow the steps in the reverse order to assemble the fuse.

Removal of VT

1. Unscrew the M10 screws (4) and remove the washer (5) provided on the mounting plate (6) on the either side of VT (7). Refer to Figure 55.
2. Remove the fuse lock (2) from fuse connection copper bar (3) and VT connection copper bar (8).
3. Remove the VT (6).

NOTE: Follow the steps in the reverse order to assemble the VT.

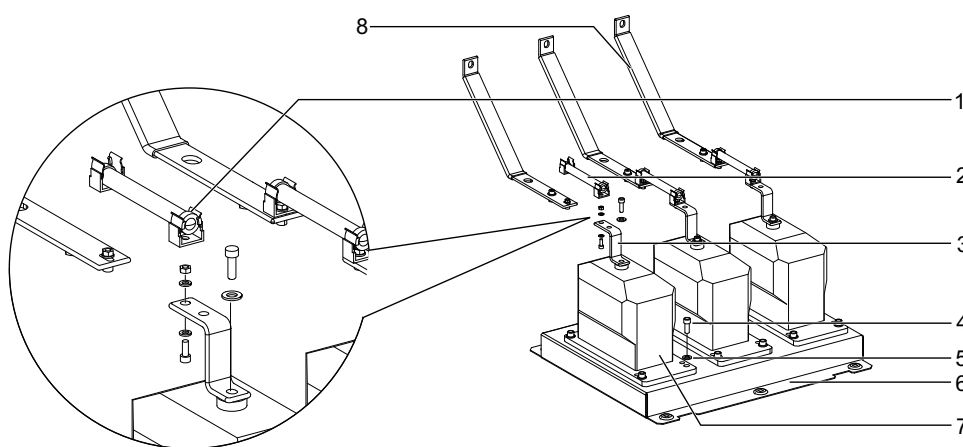

Figure 55
Removal of Fuse and VT 12/17.5 kV

1	Fuse lock	5	Washer
2	Fuse	6	Mounting plate
3	Fuse connection copper bar	7	VT
4	M10 screws	8	VT connection copper bar

Removal of Surge Arrester Assembly

1. Unscrew the M12 screws (4) provided on both sides. Refer to Figure 56.
2. Remove the terminal copper bar (2) from the VT connection copper bar (1).
3. Remove the surge arrester (3). Refer to Figure 56.

NOTE: Follow the steps in the reverse order to assemble the surge arrester.

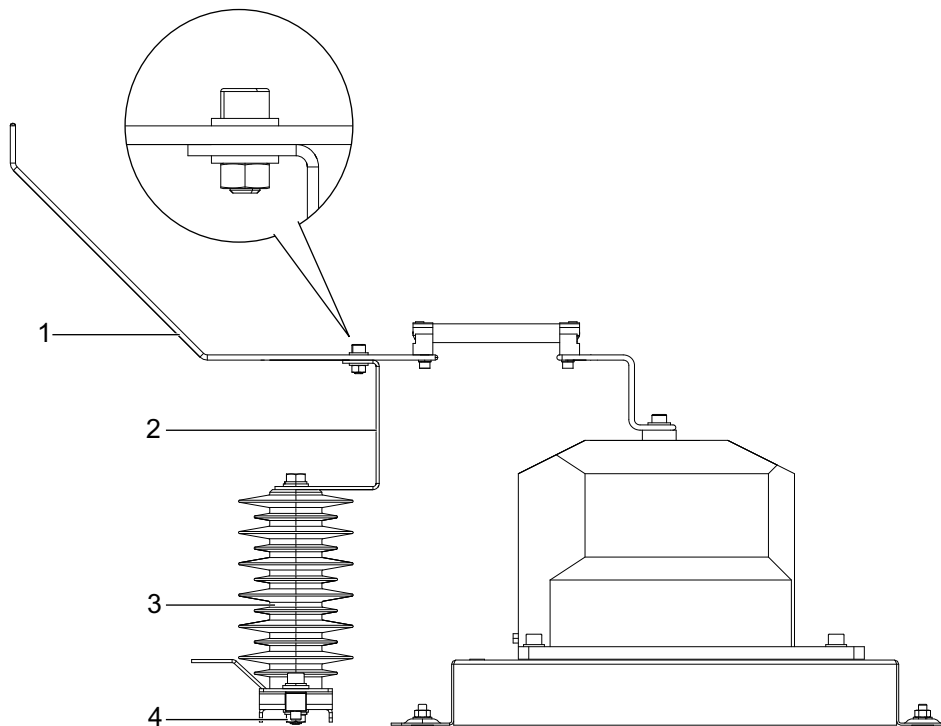

Figure 56
Removal of Surge Arrester Assembly 12/17.5 kV

1	VT connection copper bar	3	Surge Arrester
2	Terminal copper bar	4	M12 Screws

Removal of Fuse, VT, and Surge Arrester from 24 kV Cubicle

Removal of Fuse

1. Press the snap lock (1) of the fuse box, and pull it upwards.
2. Remove the fuse (2). Refer to Figure 57.

NOTE: Follow the steps in the reverse order to assemble the fuse.

Removal of VT

1. Unscrew the M10 screws (3) and remove the washer (4) provided on the mounting plate (5) on the either side of VT (6). Refer to Figure 57.
2. Unscrew fixed VT connection copper bar (7) to the CT-VT connector (8) to access the VT.
3. Remove the VT (6).

NOTE: Follow the steps in the reverse order to assemble the VT.

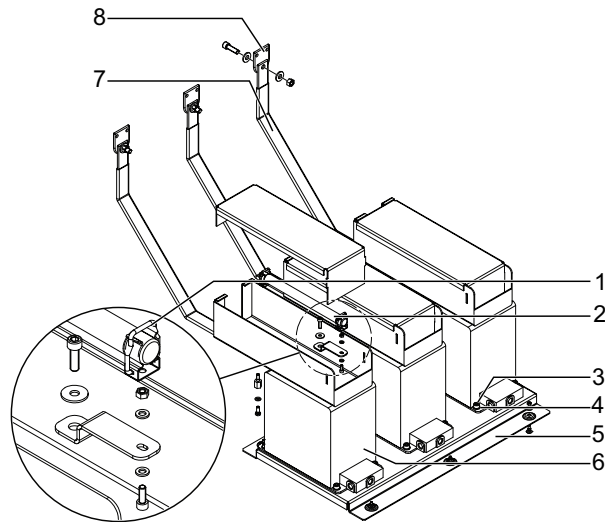

Figure 57
Removal of Fuse and VT 24 kV

- | | | | |
|---|------------|---|--------------------------|
| 1 | Snap lock | 5 | Mounting plate |
| 2 | Fuse | 6 | VT |
| 3 | M10 screws | 7 | VT connection copper bar |
| 4 | Washer | 8 | CT-VT connector |

Removal of Surge Arrester Assembly

1. Unscrew the M10 screws (1) provided on both sides. Refer to Figure 58.
2. Remove the terminal copper bar (2) from the VT connection copper bar (1).
3. Remove the surge arrester (2). Refer to Figure 48.

NOTE: Follow the steps in the reverse order to assemble the surge arrester.

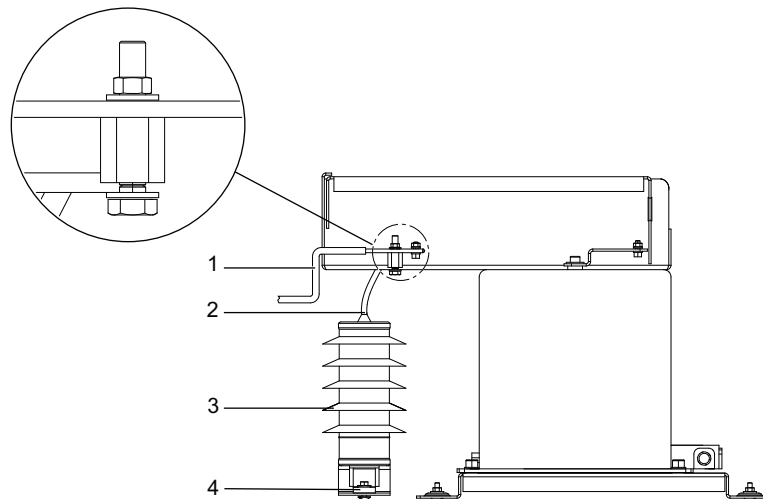

Figure 58
Removal of Surge Arrester Assembly 24 kV

- | | | | |
|---|--------------------------|---|----------------|
| 1 | VT connection copper bar | 3 | Surge Arrester |
| 2 | Terminal copper bar | 4 | M10 Screws |

After removing the fuse, VT, and surge arrester the cable compartment is fully accessible.

 **DANGER****HAZARD OF ELECTRIC SHOCK, EXPLOSION OR ARC FLASH**

- Ensure that all components (fuse, VT, surge arrester) that were removed to access the cable compartment are properly reinstalled.
- Close the cable compartment door before switching OFF the E/S.

Failure to follow these instructions will result in death or serious injury.

Closing the Cable Compartment Door

After completing assembly work, Close the cable compartment door (1) and lock the securing bolts (2) with standard double-bit key. Refer to Figure 54.

Withdrawable VT Operation

⚠️⚠️ DANGER

HAZARD OF ELECTRICAL SHOCK, EXPLOSION, OR ARC FLASH

Before opening the cable door ensure the following:

- Cable compartment not live.
- E/S is closed (if available).

Failure to follow these instructions will result in death or serious injury.

⚠️ CAUTION

HAZARD OF FALLING

Ensure the ramp is securely positioned and locked into the panel before extracting the VT.

Failure to follow these instructions can result in injury or equipment damage.

Extraction of Withdrawable VT - With Transport Locks

Follow the below steps to remove the withdrawable VT from the cable compartment:

1. Open the door (1) of the cable compartment.
2. Position the ramp (2) correctly, and securely for the removal of the withdrawable VT truck (8).

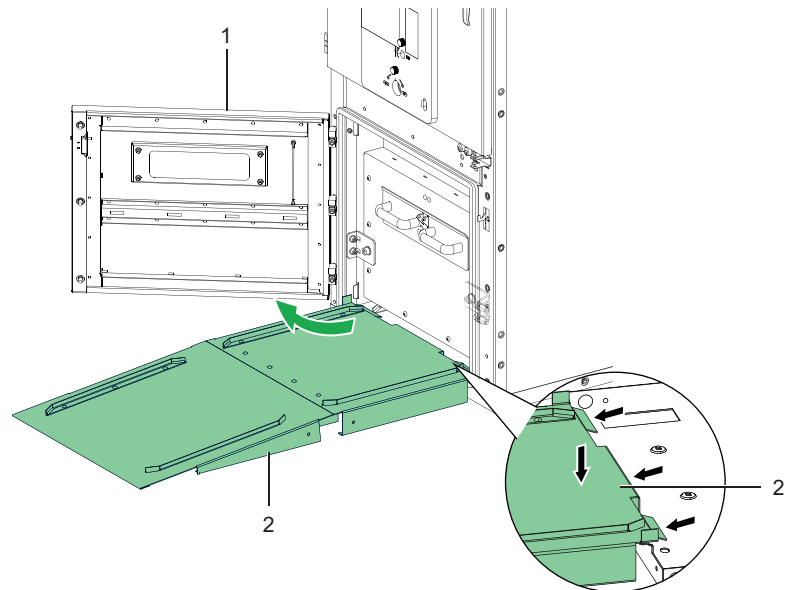

Figure 59
Access to the Withdrawable VT

- 1 Door
- 2 Ramp

- Remove the bolts (4), washers (5), bolts (7), and washers (6) from the two transportation locks (3) using an Allen key.

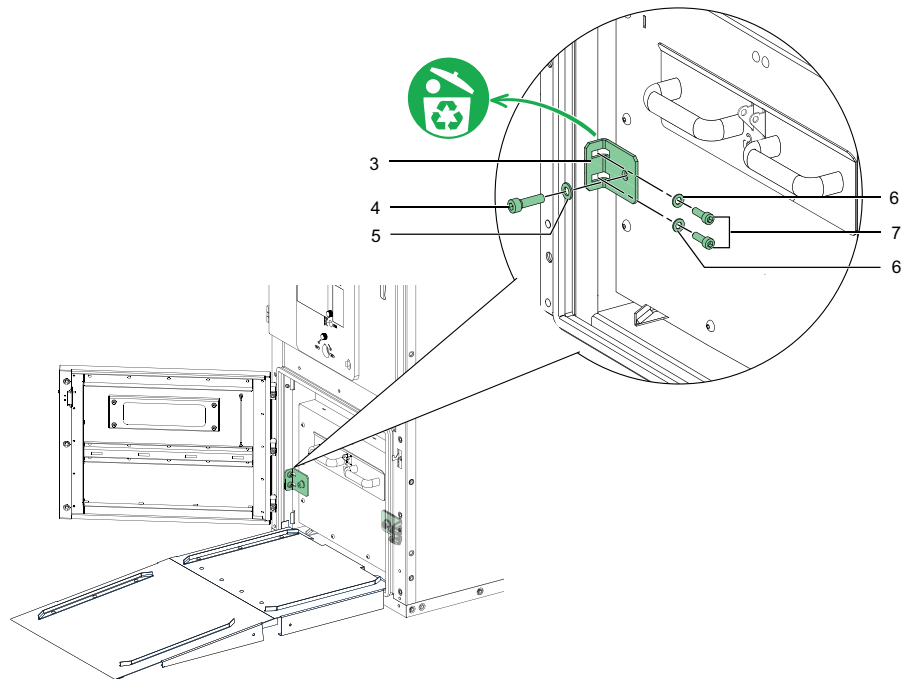

Figure 60
Remove the Transportation Locks

3	Transportation lock	6	Washer M8 x 4
4	Bolt M10 x 2	7	Bolt M8 x 4
5	Washer M10 x 2		

- Remove the transportation locks (3).
- Carefully pull out the withdrawable VT truck (8) from the cable compartment.

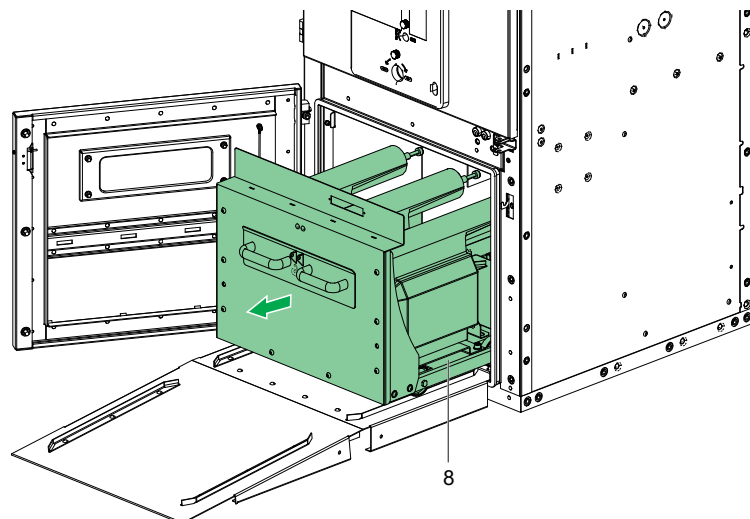

Figure 61
Position the Withdrawable VT

8	Withdrawable VT
---	-----------------

- Remove the withdrawable VT truck (8).

Insertion of Withdrawable VT

⚠️⚠️ DANGER

HAZARD OF ELECTRICAL SHOCK, EXPLOSION, OR ARC FLASH

The withdrawable VT truck must be locked into the cable compartment.

Failure to follow these instructions will result in death or serious injury.

⚠️ CAUTION

HAZARD OF FALLING

Ensure the ramp is securely positioned and locked into the panel before extracting the VT.

Failure to follow these instructions can result in injury or equipment damage.

Follow the below steps to insert the withdrawable VT truck to the cable compartment:

1. Position the ramp (1) correctly and securely to insert the withdrawable VT truck into the cable compartment.

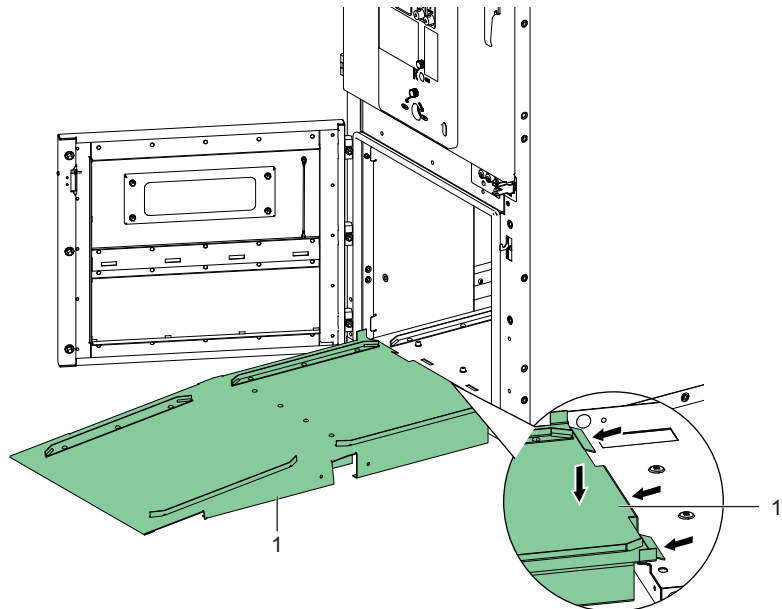

2. Carefully push the withdrawable VT truck (2) into the cable compartment.

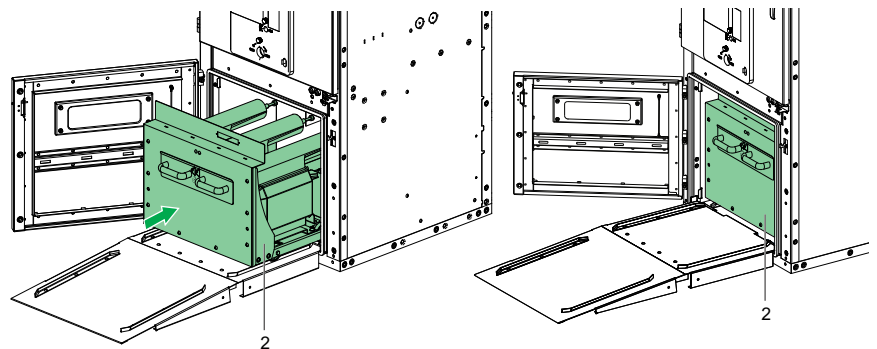

- On the withdrawable VT truck (2), push the hook (3), and the handles (4) down to lock it in the locking slot (5).

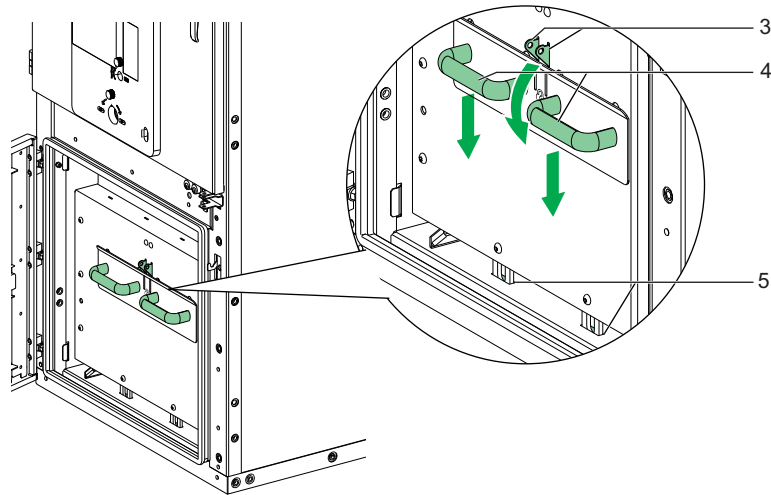

Figure 62
Insertion of withdrawable VT

- | | | | |
|---|-----------------|---|--------------|
| 1 | Ramp | 4 | Handle |
| 2 | Withdrawable VT | 5 | Locking slot |
| 3 | Hook | | |

Extraction of Withdrawable VT - Without Transportation Locks

Follow the below steps to extract the withdrawable VT if the transportation locks does not exist:

- Position the ramp correctly and securely for the removal of the withdrawable VT truck.
- On the withdrawable VT truck (3), push the hook (1), and lift the handles (2) up to unlock it from the service position.

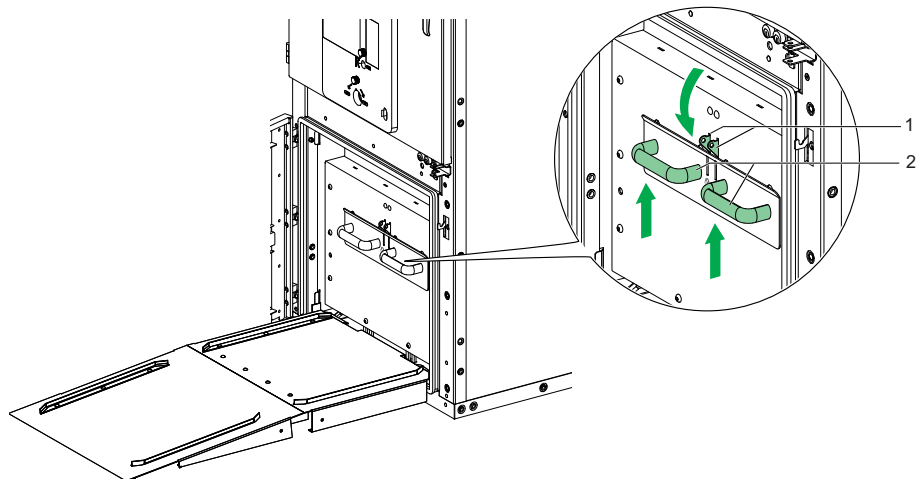

- Carefully pull out the withdrawable VT truck (3) from the cable compartment.

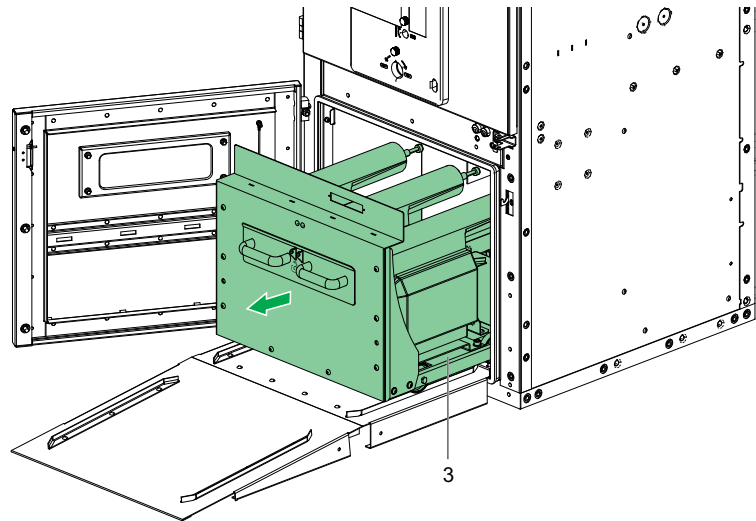

Figure 63
Position the Withdrawable VT

- | | | | |
|---|--------|---|-----------------|
| 1 | Hook | 3 | Withdrawable VT |
| 2 | Handle | | |

- Remove the withdrawable VT truck (3).

Access to the Cable Compartment via the VCB Compartment

To access the cable compartment via VCB compartment:

1. Extract the VCB from the panel. Refer to *Extraction of the EvoPacT HVX VCB from the Cubicle*, page 84.
2. To remove the horizontal partition plate from the VCB compartment:
 - Unscrew the four securing bolts of the horizontal partition.
 This will allow access to the cable compartment from above.
3. Open the cable compartment door (4). Refer to *Access to the Cable Compartment*, page 64.
4. The cable compartment is fully accessible.

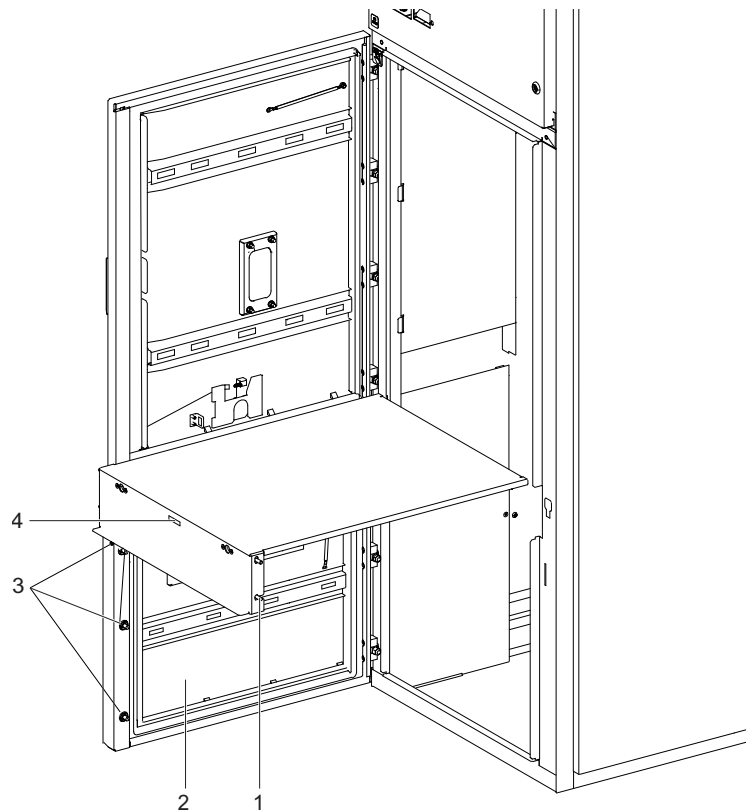

Figure 64
Access to cable compartment via VCB compartment

- | | | | |
|---|------------------------|---|----------------------------------|
| 1 | Bolts | 3 | Cable compartment securing bolts |
| 2 | Cable compartment door | 4 | Horizontal plate |

NOTE: Follow the above steps in reverse order to remount the cover plate

Access to the Cable Compartment from Rear Side AFLR

⚠ ⚠ DANGER

HAZARD OF ELECTRIC SHOCK, EXPLOSION OR ARC FLASH

- Rear access must only be accessed with AFLR internal arc classification.
- Ensure the VCB is in disconnected/test or racked-out position inside the cubicle.
- Ensure the E/S is in a closed or earthed.
- Isolate the cubicle from the power supply.
- Obtain work permission for zero voltage from the relevant team.

Failure to follow these instructions will result in death or serious injury.

Removal of Cable Compartment Rear Cover

Follow the below steps to open the rear cable access door:

1. Unscrew the M8 x 25 screws (3) and remove the M8 plain washers (2) by using an Allen key. Refer to Figure 54 and Figure 65.
2. Remove the rear cover (1).
3. The cable compartment is now accessible from the rear side (AFLR).

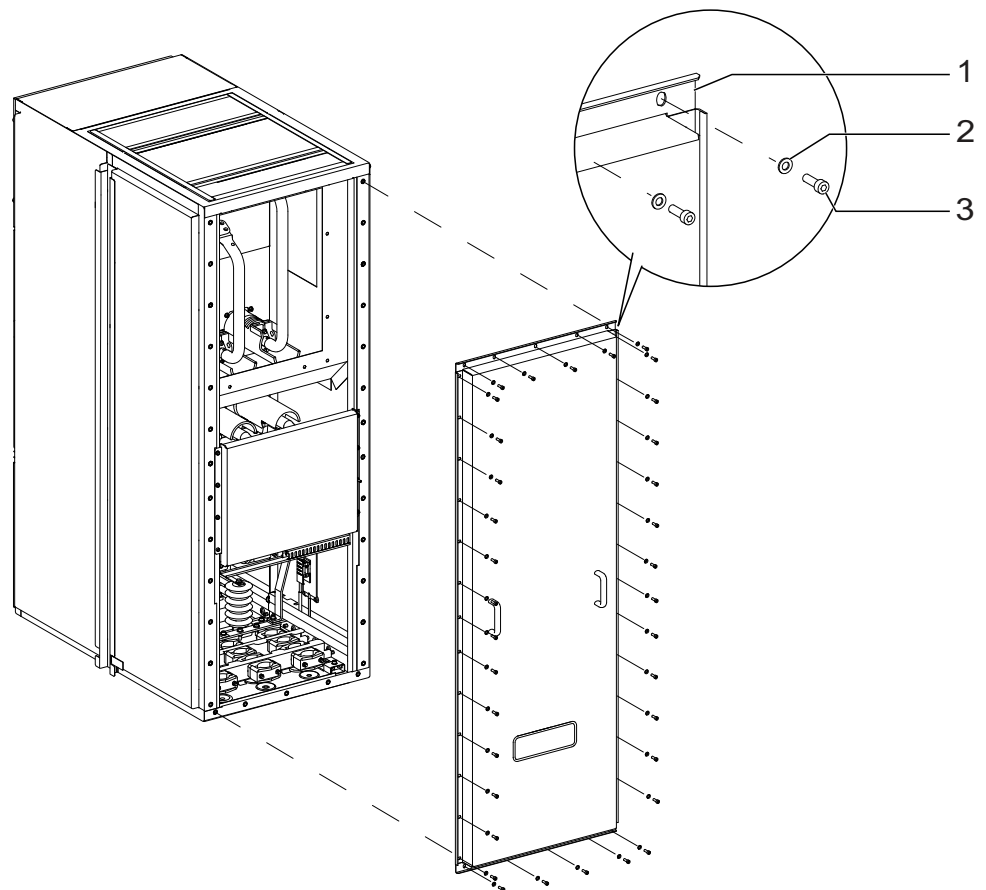

Figure 65
Rear Access of the Cable Compartment 12/17.5 kV

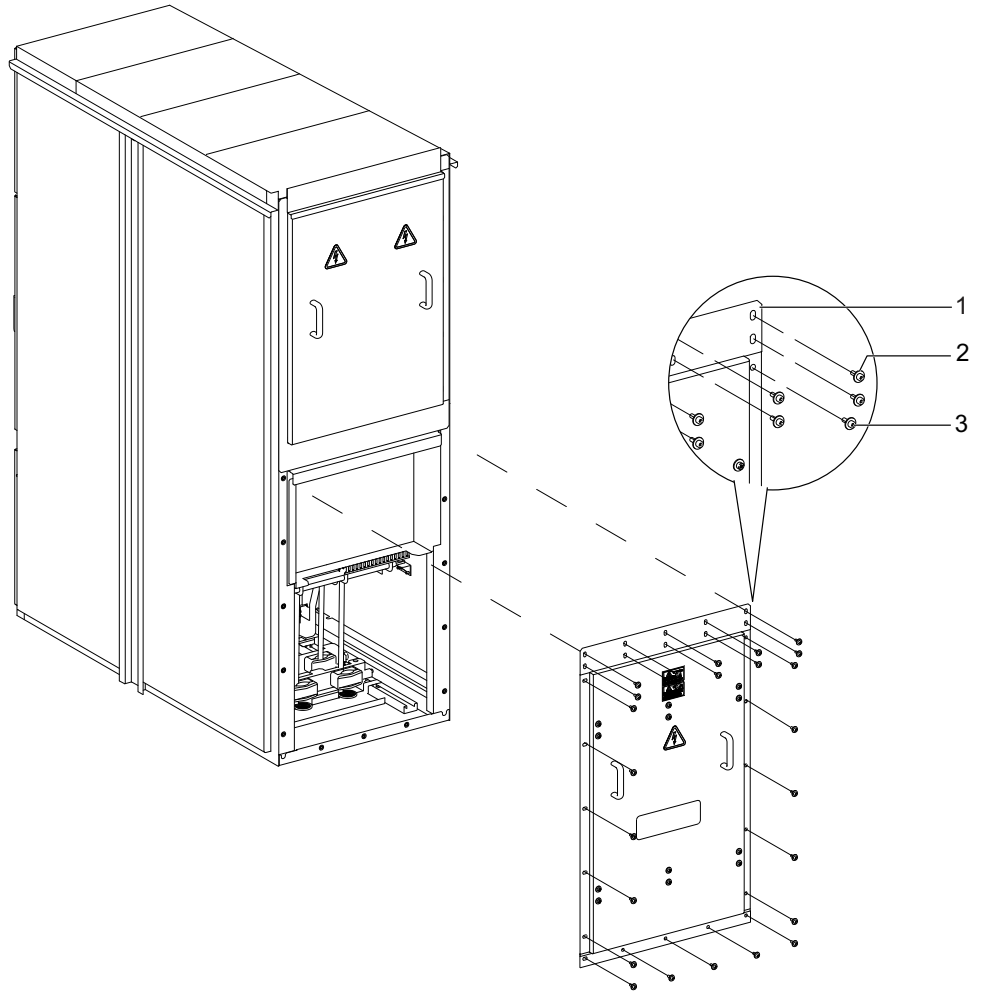

Figure 66
Rear Access of the Cable Compartment 24 kV

- 1 Rear cover
- 2 Washer M8
- 3 Screws M8 x 25

NOTE: After completing assembly work, follow the above steps in reverse order to remount the cable compartment rear cover.

Access to the Contactor Cubicle Cable Compartment

⚠ ⚠ DANGER

HAZARD OF ELECTRIC SHOCK, EXPLOSION OR ARC FLASH

Before accessing the cable compartment, ensure the E/S is ON. Refer to Switching ON the Contactor Cubicle E/S, page 58.

Failure to follow these instructions will result in death or serious injury.

Additional cylinder locks can be installed to help secure both the cable compartment door and the switching device compartment door of the cubicle.

Removal of the Cable Compartment Door

Follow the below steps to open the cable compartment door:

1. Lift and turn the cable compartment cover. Refer to Figure 67.
2. Once the assembly is complete, gently lift the cable compartment door, turn it to the closed position, and lower it to close.

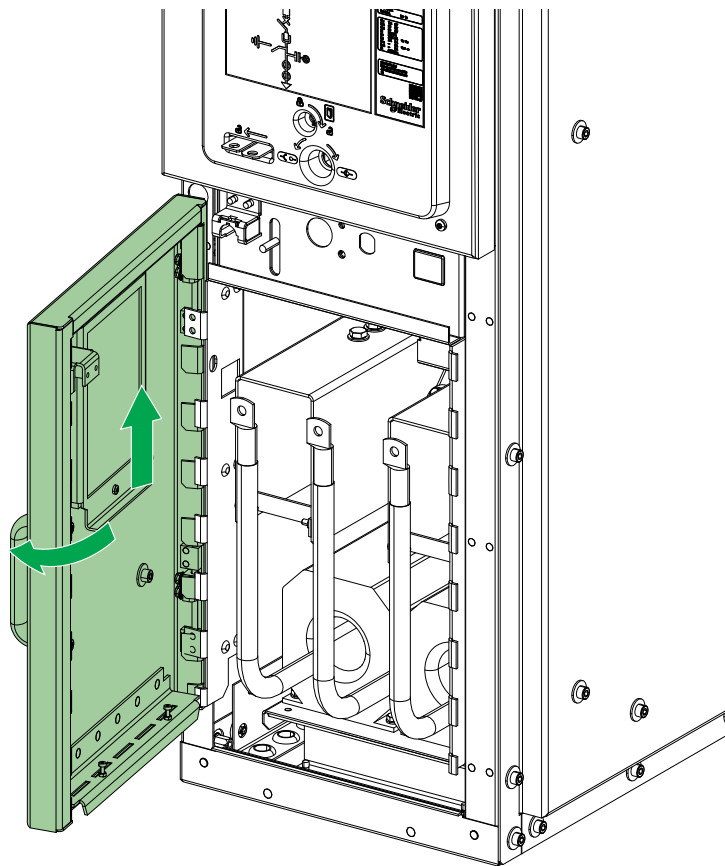

Figure 67
Removal of the Cable Compartment Door

Access to the EvoPacT HVX VCB Compartment

⚡ ⚠ DANGER

HAZARD OF ELECTRIC SHOCK, EXPLOSION OR ARC FLASH

- Make sure that the racking device is in disconnected/test position before opening the front door.
- Turn off all power supply or de-energize the complete cubicle because opening any door is not allowed if the busbar or cable is live.

Failure to follow these instructions will result in death or serious injury.

Opening and Closing the VCB Front Door

Opening the Front Door

1. Hold the door handle, and pull it upwards.
2. Swing the door to the left side. Refer to Figure 68.

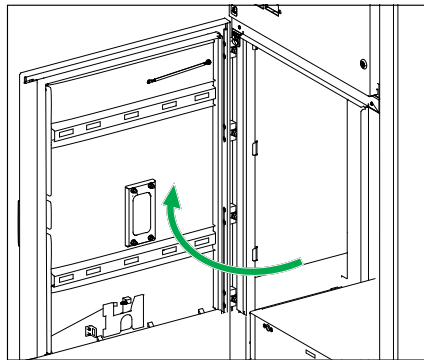

Figure 68
Access to the Main VCB Compartment

Closing the Front Door

1. Close the door completely.
2. Turn the handle downwards for the full stroke.

Removal and Insertion of LV Connector

The LV connector can only be removed or inserted while the truck is in its disconnected/test position.

Removal of LV Connector

1. Pull the interlocking lever of the LV connector forward and remove the connector.
2. Fix the LV connector to the pin on the EvoPacT HVX VCB.

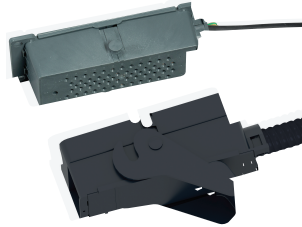

Figure 69
LV Connector EvoPacT HVX VCB

Insertion of LV Connector

1. Remove the LV connector from the fixation pin on the EvoPacT HVX VCB. Refer to Figure 69.
2. Insert the LV connector into the socket of interchangeability interlock inside the cubicle above the EvoPacT HVX VCB (2).

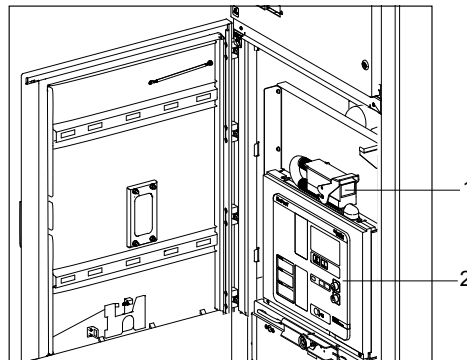

Figure 70
LV Connector Inside the Cubicle

- 1 LV Connector
- 2 EvoPacT HVX VCB

Insertion of the EvoPacT HVX VCB into the Cubicle

Insertion of the device to be performed during installation or maintenance phase.

To enable easy insertion of the VCB, Schneider Electric recommends using a transport trolley to securely carry the device in locked position to its insertion point, with the respective equipment configuration (650/800/1000 mm).

NOTE: Transport trolley is supplied with cubicles.

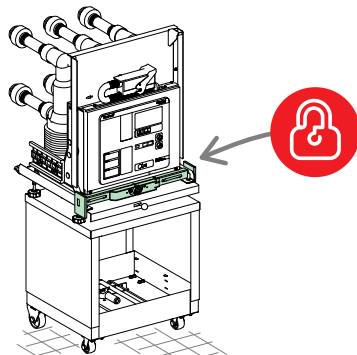

Figure 71
Trolley and VCB with Locked Position

Initial situations:

- The VCB is closed/off, discharged and in disconnected/test position. Refer to Figure 72.
- The cubicle shutters are not padlocked.

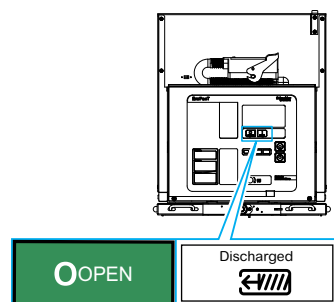

Figure 72
VCB with Off and Discharged Condition

Follow the below steps for insertion of the EvoPacT HVX VCB into the Cubicle:

1. Open the VCB compartment door. Refer to *Opening and Closing the VCB Front Door*, page 78.
2. Check the compartment for
 - Cleanliness in accordance with the service conditions.
 - No installation scraps or items have been left inside (tools, electrical wires, broken parts or shreds, metal objects and so on).

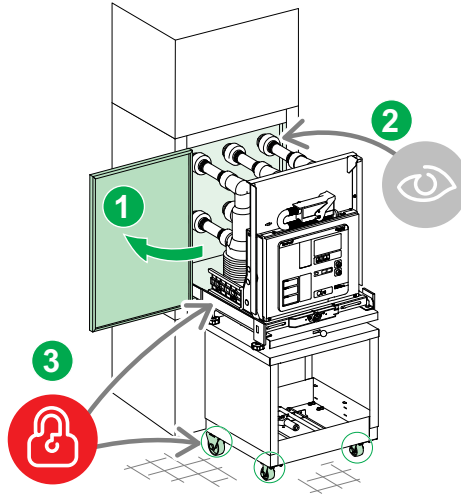

Figure 73
Before Insertion of VCB

3. Position the transport trolley in front of the cubicle. Refer to the Figure 73.

⚠ WARNING

HAZARD OF FALLING OR TOPPLING

- Make sure that the pins of the transport trolley is properly aligned to the holes on the cubicle.
- Move the transport trolley towards the cubicle until the secure lock engages with the cubicle and firmly arrests it in place.

Failure to follow these instructions can result in death, serious injury, or equipment damage.

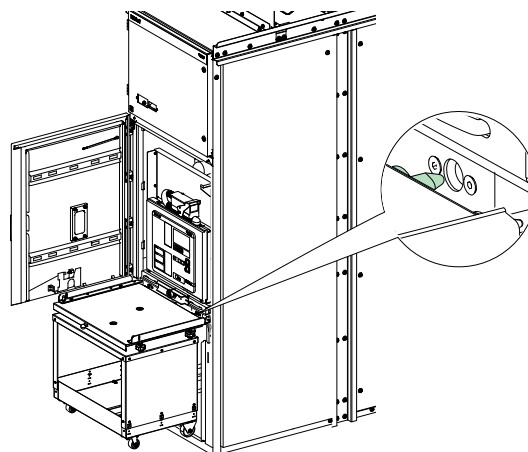

Figure 74
Aligning Trolley with the Cubicle

- De-latch the locking handles towards each other to release the VCB from the transport trolley. Refer to Figure 75.

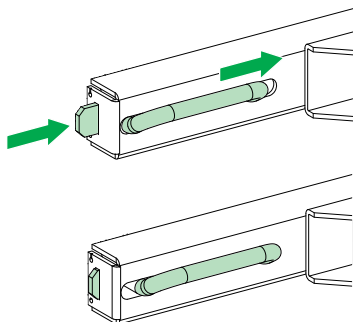

Figure 75
De-latching the Locking Handles

- Push the VCB by holding the locking handles, into the VCB cubicle to its test position. Refer to Figure 76.

NOTICE
<p>HAZARD OF INAPPROPRIATE OPERATION</p> <ul style="list-style-type: none"> • LV plug must be connected. • LV plug must be locked. <p>Failure to follow these instructions can result in equipment damage.</p>

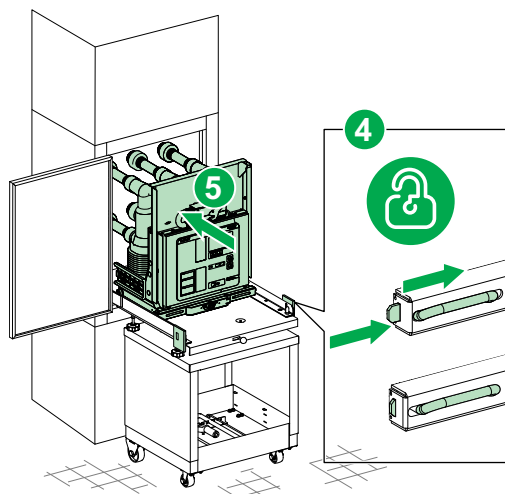

Figure 76
Insertion of VCB into the Cubicle

6. Latch the locking handles of the VCB in the cubicle.

NOTE: Latch the locking handles of the VCB truck away from each other to latch VCB with the transport trolley. Refer to the Figure 77.

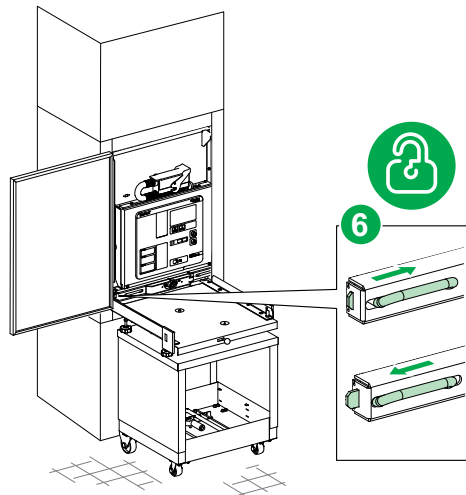

Figure 77
Insertion of VCB into the Cubicle

7. Firmly hold the transport trolley and then push the knob (7) of the transport trolley to the left-hand side of the interlock to open, and remove the transport trolley from the cubicle. Refer to Figure 78.

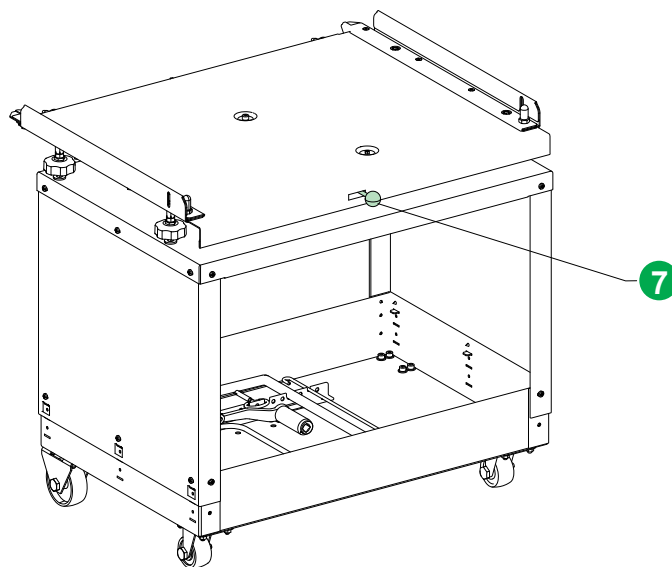

Figure 78
Knob of the Trolley

8. If necessary, perform the test operations.
9. Close the VCB compartment door. Refer to Opening and Closing the VCB Front Door, page 78.

Extraction of the EvoPacT HVX VCB from the Cubicle

Extraction of the device to be performed during installation or maintenance phase.

Initial situations:

- The device is in disconnected/test position.
- The VCB is OFF and discharged position. Refer to Figure 71 in Insertion of the EvoPacT HVX VCB into the Cubicle, page 80.

Follow the below steps for extraction of the EvoPacT HVX VCB from the cubicle:

1. Open the VCB compartment door. Refer to Opening and Closing the VCB Front Door, page 78.
2. Disconnect LV auxiliary connection from the VCB. Refer to Removal and Insertion of LV Connector, page 79.
3. Check the device indicators and, if necessary, operate the circuit breaker mechanically to place it in the OFF and discharged position. Refer to Figure 72 in Insertion of the EvoPacT HVX VCB into the Cubicle, page 80.
4. Position the transport trolley in front of the cubicle.

⚠ WARNING

HAZARD OF FALLING OR TOPPLING

- Make sure that the pins of the transport trolley is properly aligned to the holes on the cubicle.
- Move the transport trolley towards the cubicle until the secure lock engages with the cubicle and firmly arrests it in place.

Failure to follow these instructions can result in death, serious injury, or equipment damage.

5. De-latch the locking handles towards each other to release the VCB from the cubicle. Refer to Figure 75 in Insertion of the EvoPacT HVX VCB into the Cubicle, page 80.
6. Pull the VCB by holding the locking handles, from the VCB cubicle to transport trolley. Refer to Figure 79.

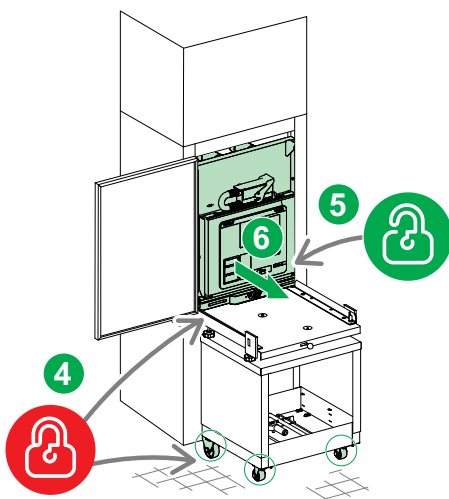

Figure 79

Extraction of VCB from the Cubicle

NOTE: The interlocking handles of the VCB will move automatically apart and fix the VCB on the transport trolley.

7. Latch the locking handles of the VCB in the cubicle. Refer to Figure 75 in Insertion of the EvoPacT HVX VCB into the Cubicle, page 80.

NOTE: Latch the locking handles of the VCB truck away from each other to latch VCB on the transport trolley.

8. Firmly hold the transport trolley and push the knob of the transport trolley to the left-hand side of the interlock to open and remove the transport trolley from the cubicle. Refer to Figure 77 in Insertion of the EvoPacT HVX VCB into the Cubicle, page 80.
9. Close the VCB compartment door. Refer to Opening and Closing the VCB Front Door, page 78.
10. Place the transport trolley in its designated place with due care.

Access to the Contactor Cubicle Switching Device Compartment

⚡ ⚠ **DANGER**

HAZARD OF ELECTRIC SHOCK, EXPLOSION OR ARC FLASH

- Make sure that the racking device is in disconnected/test position before opening the switching device compartment door.
- Turn OFF all power supply or de-energize the complete cubicle before opening any door, as opening is not allowed when the busbar or cable is live.

Failure to follow these instructions will result in death or serious injury.

Opening and Closing the Switching Device Compartment Door

Opening the Door:

1. To unlock the door (1), insert the appropriate double-bit key (4) in the door lock (3) and turn it clockwise to its stop. The door (1) is unlocked.
2. Lift the switching device compartment door (1) using the two handles (2) and remove it.
3. Remove the double-bit key (4) and keep it in a safe place.

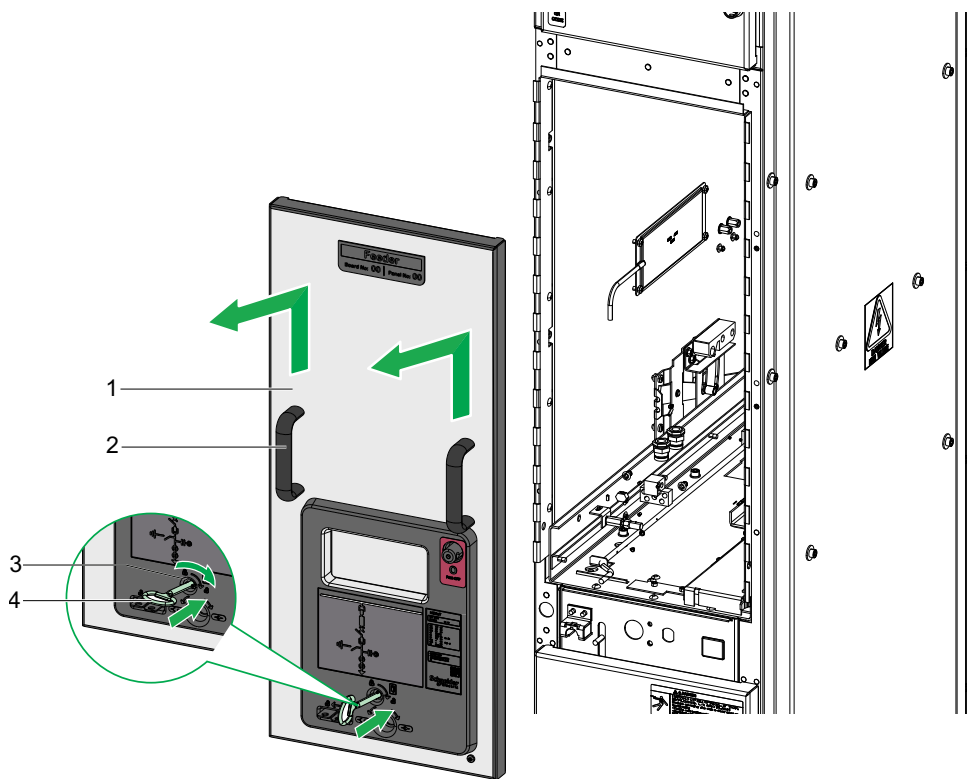

Figure 80
Opening and Closing the Switching Device Compartment Door

- | | | | |
|---|-----------------------------------|---|----------------|
| 1 | Switching device compartment door | 3 | Door lock |
| 2 | Handle | 4 | Double-bit key |

Closing the Door:

1. Pick up the switching device compartment door (1) using the two handles (2), place it in the cutout on the cubicle and lower it.
2. Insert the double-bit key (4) used to unlock the door into the lock (3) on the switching device compartment door (1) and turn it counter-clockwise to its stop. The door is locked.
3. Remove the double-bit key (4) and keep it in a safe place.

Access to the Busbar Compartment

⚡⚠ DANGER

HAZARD OF ELECTRIC SHOCK, EXPLOSION, OR ARC FLASH

Before accessing the busbar compartment from rear side, ensure the following:

- VCB in the I/F cubicle is in test/isolated position.
- E/S of the respective cubicle is switched ON.
- E/S/earthing device in BME cubicle is switched ON.

Failure to follow these instructions will result in death or serious injury.

Access to the Busbar Compartment from Front Side AFL

⚡⚠ DANGER

HAZARD OF ELECTRICAL ARC, EXPLOSION AND FIRE

- Ensure EvoPacT HVX VCB must be in OFF and disconnected/test condition.
- Ensure the E/S is in a closed or earthed condition.
- Check the VDIS indication.
- Isolate the cubicle from the power supply.
- Obtain work permission for zero voltage.

Failure to follow these instructions will result in death or serious injury.

Follow the below steps to access the busbar from front side:

1. Remove the VCB safely from the cubicle. Refer to the [Extraction of the EvoPacT HVX VCB from the Cubicle](#), page 84.
2. Remove the M8 bolts along with washers, and disassemble the maintenance sheet (1). Refer to Figure 81.

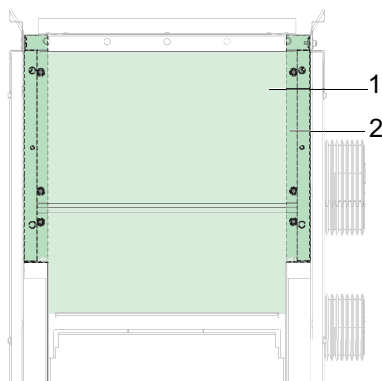

Figure 81
Front Access of Busbar

- 1 Maintenance sheet
- 2 Securing bolts

3. The busbar compartment is accessible.

Access to the Busbar Compartment from Rear Side AFLR

⚠ WARNING
HAZARD OF INAPPROPRIATE OPERATION
The rear access must be accessed only with AFLR internal arc classification.
Failure to follow these instructions can result in death, serious injury, or equipment damage.

Follow the below steps to access the 12/17.5 kV busbar compartment from rear side (AFLR):

1. Remove the rear cover (4) of the cubicle by unscrewing M8 screws (2) and washers (3) provided on rear cover (4). Refer to Figure 82.
2. To remove the maintenance sheet (1), remove the M8 screws (2) and washers (3), and disassemble the maintenance sheet (1). Refer to Figure 81 Access to the Busbar Compartment from Front Side AFL, page 88.

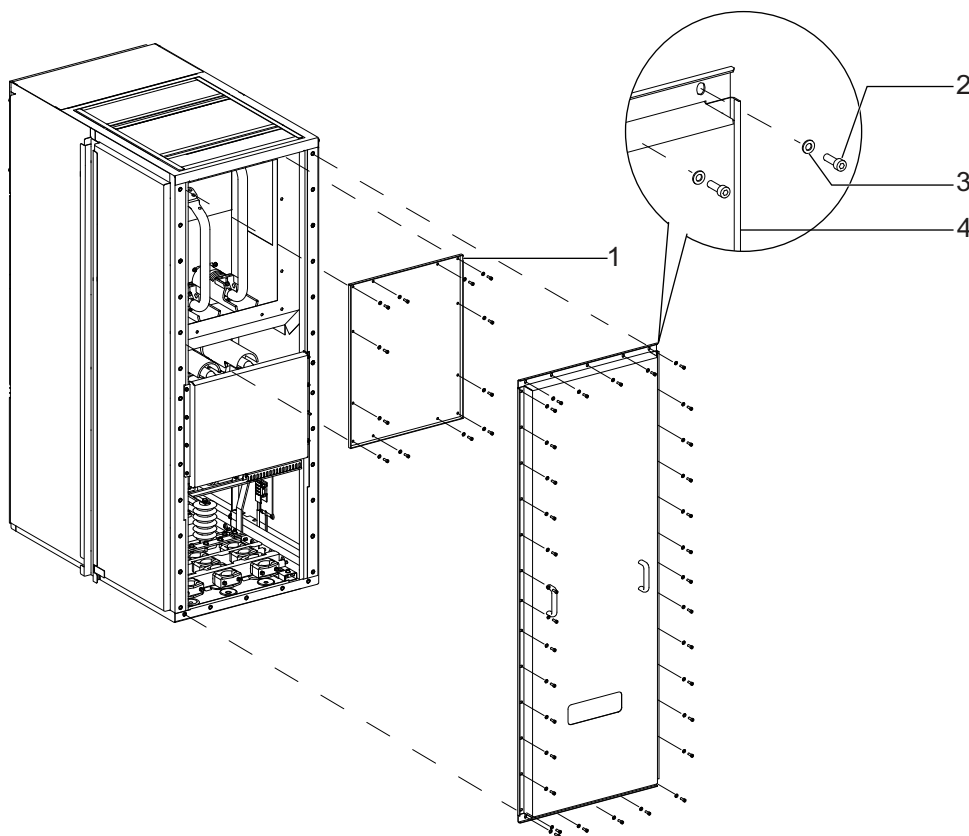

Figure 82
Rear Access of Busbar 12/17.5 kV

- | | | | |
|---|-------------------|---|------------|
| 1 | Maintenance sheet | 3 | Rear cover |
| 2 | Screw M8 x 25 | 4 | Washer M8 |

Follow the below steps to access the 24 kV busbar compartment from rear side (AFLR):

1. To remove the rear cover of the cubicle, first remove the bottom rear cover (5) of the cubicle by unscrewing M8 screws (4) and washers (3) provided on rear cover. Refer to Figure 83.
2. Open the top rear cover (2).

3. To remove the maintenance sheet (1), remove the M8 screws (4) and washers (3), and disassemble the maintenance sheet (1). Refer to Figure 81 Access to the Busbar Compartment from Front Side AFL, page 88.

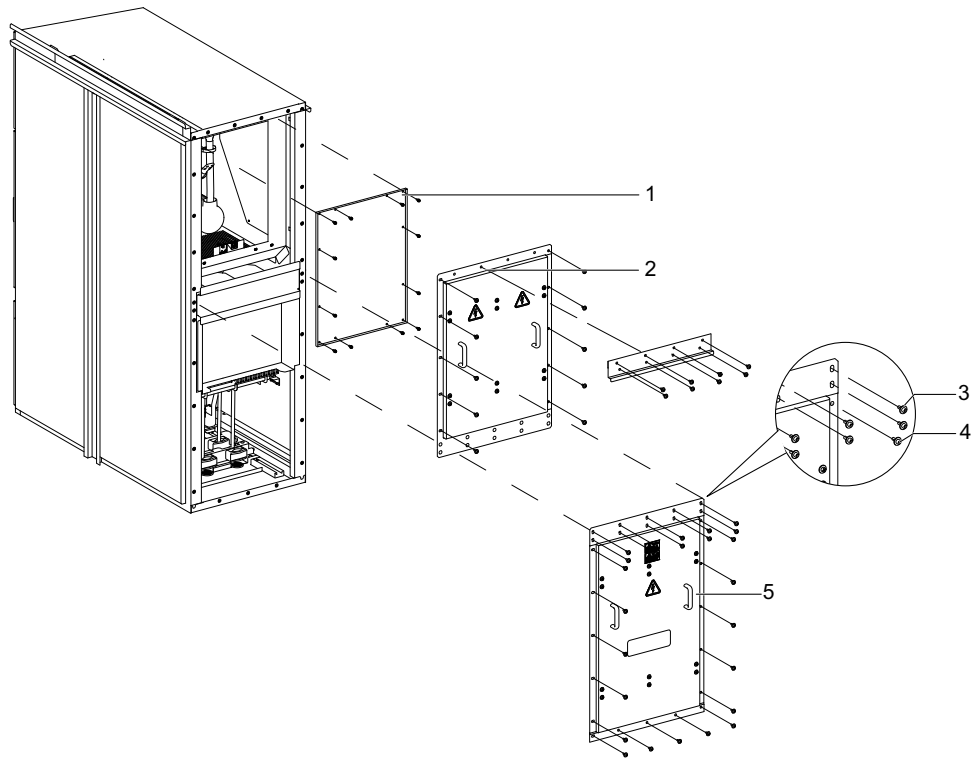

Figure 83
Rear Access of Busbar 24 kV

- | | | | |
|---|-------------------|---|-------------------|
| 1 | Maintenance sheet | 4 | Screw M8 x 25 |
| 2 | Top rear cover | 5 | Bottom rear cover |
| 3 | Washer M8 | | |

Maintenance

Safety Provisions

Before performing work on the cubicle, it is essential that you comply with the following instructions:

DANGER

HAZARD OF ELECTRIC SHOCK, EXPLOSION, OR ARC FLASH

Before removing covers and performing assembly or maintenance work:

- Ensure that the system is isolated from high voltage, supply voltage, and properly grounded.
- Ensure that the VCB is in test condition, the E/S is closed, and access is locked.
- Follow the LOTO process to perform any work on switchboard.
- Install barriers, cables, and polycarbonates in accordance with the design specifications wherever necessary.

Failure to follow these instructions will result in death or serious injury.

WARNING

HAZARD OF MOVABLE PARTS IN MECHANICAL DRIVES

Before performing mounting and maintenance work, comply with the below safety rules:

- Isolate from the supply voltage.
- Release the energy-storing device of the VCB by performing the OFF-ON-OFF operation.
- Activate the make-proof E/S to ON position, to ensure that the equipment is ready for use (if any).
- Do not remove the mechanisms during maintenance work.

Failure to follow these instructions can result in death, serious injury, or equipment damage.

WARNING

HAZARD OF SHARP-EDGED SHEET METAL AND METAL PARTS

During installation and maintenance work, comply with the below safety rules:

- Apply appropriate PPE and follow safe electrical work practices. See standards or local equivalent.
- Always cover sharp edges.

Failure to follow these instructions can result in death, serious injury, or equipment damage.

Overview

The maintenance interval of the MCSeT cubicles relies primarily on its usage, environmental conditions, and its connection to the Schneider Electric cloud.

When the MCSeT cubicles are not connected to the cloud, all maintenance actions occur at fixed periodicity.

When the MCSeT cubicle is connected to the cloud, manufacturer maintenance periodicity becomes condition-based, and allows periodicity extension up to 2 years. Assets connected to the cloud enable live monitoring, rescheduling the manufacturer maintenance date at the right time for dynamic condition-based maintenance.

The dynamic stage is determined by the Maintenance Index computed in EcoStruxure Asset Advisor.

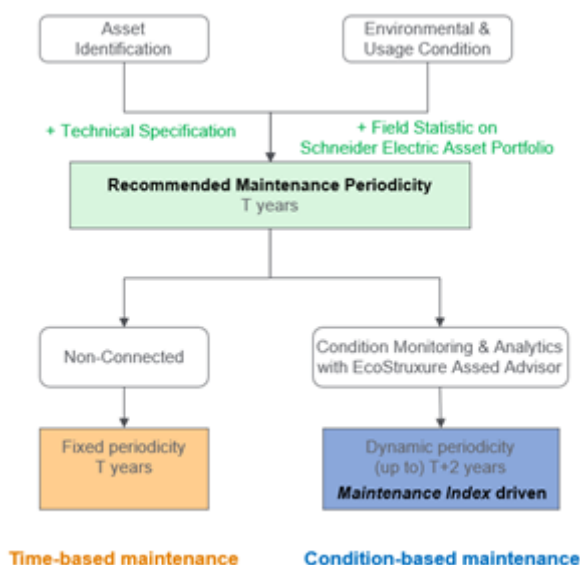

Figure 84
Principle for Electrical Distribution Equipment Maintenance

Preventive Periodic Maintenance

Schneider Electric maintenance intervals is structured in two distinct levels:

- **Inspection maintenance:** Simple preventive maintenance is carried out by Schneider Electric experts, service providers, or competent customer technicians.
- **Manufacturer maintenance:** Only Schneider Electric experts perform extensive preventive maintenance, which includes ProDiag diagnostics when possible.

Maintenance Periodicity

The maintenance plan for non-connected assets follows a time-driven schedule involving inspection/manufacturer maintenance interventions.

NOTE: Depending on the customer preference, they can opt for time-based maintenance for connected assets while still receiving maintenance recommendations based on an index for anticipated maintenance.

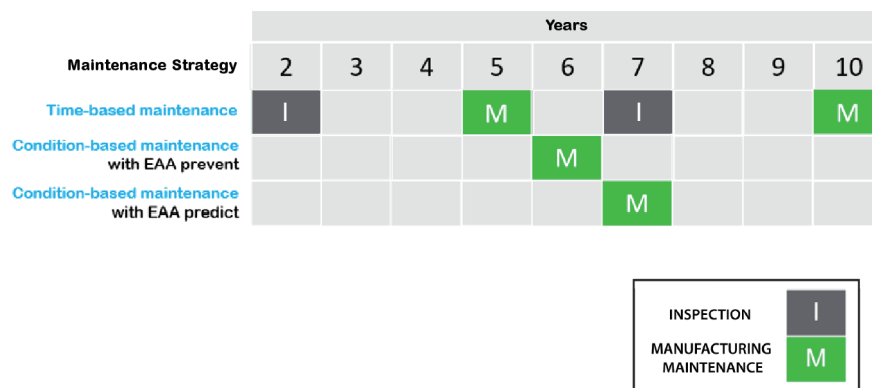

Figure 85
Maintenance Periodicity for Non-Connected and Connected Assets

If there is unusual changes or changes in usage and environmental conditions, the maintenance interval will change from 5 to 4 years, indicating the need to reschedule the next maintenance interval.

When the intermediate maintenance is performed, the actions for the routine maintenance are also performed.

When the manufacturer maintenance is performed, the intermediate maintenance is also performed.

The maintenance periodicity can be optimized depending on the environmental conditions, and on equipment usage conditions.

Table 16 Environmental Factors

Environmental Factors	Normal (all the criteria is to be fulfilled)	Severe (from one criterion checked)
Temperature average annual around/out of switchgear	T < 35	T > 35
Humidity Relative	H < 85%	H > 85%
Salinity site distance from seaside and room with no protected atmosphere	Low salt mist D > 10 km	High salt mist D < 10 km
Dust level further to filtration and/or ventilation present	Low dust level or filtration and/or ventilation present	High dust level and no filtration and nor ventilation present
Maintenance cycle	T = 5 years	T = 4 years based on site condition at customer discrete

Manufacturer Maintenance when Connected to the Cloud

If the MCSeT product is connected to Schneider Electric cloud, the equipment condition is monitored in live.

- The manufacturer maintenance is scheduled depending on the operating conditions.
- Maintenance periodicity is condition-based allowing a periodicity extension up to two years.
- Dynamic condition-based maintenance is managed by a **Maintenance index** computed the Schneider Electric EcoStruxure Asset Advisor application in the cloud. The Manufacturer maintenance interval can be extended to six or seven years depending upon the type of Ecostruxure Asset Advisor.
 - **Preventive:** Up to 6 years further to operating/services conditions continuously monitored.
 - **Predictive:** Up to 7 years further to operating/services conditions continuously monitored and asset health computation.

NOTE: Between two consecutive maintenances by manufacturer, the inspection is still required.

Checklist for Maintenance Activities

Table 17 Inspection maintenance of cubicle with VCB/CVX

LV Compartment
Visual inspection of auxiliaries equipment
Visual inspection of wiring connections (tightening, fixing, and proper connection)
VCB/CVX Compartment
Cleaning cubicle/dedusting/internal equipment
Inspection of the position indicators and signalling micro switches
Perform and verify manual operations and interlocks
Perform and verify electrical operations and interlocks
Shutters visual inspection if applicable (chalking, cracking, and signs of heating)
Check keylocks and padlocks, if present
Check voltage indication devices
Cables Compartment
Inspection of cables (tighting, chalking, and signs of heating)
Inspection of wiring connections (tightening and fixing)
VT withdrawal mechanism inspection if applicable
Cleaning/inspection of insulators (chalking, cracking, and signs of heating)
Cleaning/inspection of CT/VT's (tightening, chalking, cracking, and signs of heating)
Forced cooling fan 20000 – 30000 hrs: NOTE: Run the fan for at least two hours every month when it is not used for long periods, especially in humid environments. This helps prevent moisture buildup.
Busbar Compartment
Inspection of busbars (cleaning, tightening, chalking, cracking, and signs of heating)
Inspection of isolator switches (cleaning, tightening, chalking, cracking, and signs of heating)
VCB⁽¹⁾
General state: Visual checking, cleanliness, insulator condition, oxidation, and no corrosion of supporting structure
Checking of number of operation
Cleaning of resin bodies
Inspection of state of the auxiliaries contact (ON/OFF, rack-in, and rack-out etc.)
Inspection of functional and safety interlock on device
Checking of LV plug if applicable
Perform ON/OFF operation
Perform rack IN/OUT operation if applicable
Cleaning/checking/light greasing of the power contacts (plugs and sliding contacts)
Forced cooling fan 20000 – 30000 hrs: NOTE: Run the fan for at least two hours every month when it is not used for long periods, especially in humid environments. This helps prevent moisture buildup.
Fuses
Cleaning/visual/verification inspection of fuse (chalking, color, cracking, and corrosion)
Cleaning/visual/verification inspection of fuse fixing
Cleaning/visual/verification inspection of fuse signaling micro switch

Table 17 Inspection maintenance of cubicle with VCB/CVX (Continued)

Cleaning/visual/verification inspection of fuse striker
⁽¹⁾ Please refer to specific VCB documentation for further details.

Table 18 Manufacturer maintenance

LV Compartment
Inspection/Verification of protection relay (setting and tripping functions)
Inspection/verification of logic selectivity
ProDiag relay analysis
VCB/CVX Compartment
Verification of switch line operating mechanism
Cleaning/checking of isolators (tightening, chalking, cracking, and signs of heating)
Cleaning/checking of earthing switch operating mechanism
Cleaning/checking/greasing of earthing switch plugs
Cleaning/checking/greasing of shutter locking system
ProDiag corona analysis
Cables Compartment
Verification of insulator (chalking, cracking, and signs of heating)
Verification of CT/VT's (tightening, chalking, cracking, and signs of heating)
Busbar Compartment
Verification of busbars (cleaning, tightening, chalking, cracking, and signs of heating)
Verification of isolator switches (cleaning, tightening, chalking, cracking, and signs of heating)
VCB⁽¹⁾
Measurement of main contact resistance (micrometer)
Cleaning/checking/greasing of the moving withdrawable parts
Checking of coupling rods
Cleaning/checking/greasing of the operating mechanism
Cleaning/checking/greasing of the latching mechanism
Cleaning/checking/greasing of the closing and opening springs
Cleaning/checking/greasing of the motor
Cleaning/checking/greasing of all linkages
Check LV electrical wiring connections
ProDiag CB analysis
Fuses
Verification /greasing of fuse striker and linkages
ProDiag fuse analysis
⁽¹⁾ Please refer to specific VCB documentation for further details.

Cleaning

DANGER

HAZARD OF ELECTRICAL ARC, EXPLOSION AND FIRE

- To maintain the cubicle insulating level, ensure that the insulating components are clean.
- Wear appropriate PPE before any cleaning operation.
- Only use the cleaning agent specified by Schneider Electric (reference no. S008152).
- Check the cubicle for any dirt buildup.
- Clean the contaminated components with a dry, clean, and lint free cloth.
- Depending on the level of soiling, replace the cloth as required.
- Soak the cloth thoroughly in a recommended cleaning agent and wipe the insulating components.
- Keep the duration of exposure as short as possible.
- Expose the cleaned surface to air at least for two hours.

Failure to follow these instructions will result in death or serious injury.

Avoid Condensation

To maintain the specific insulation level, it's crucial to shield the switchgears, particularly insulation parts, from condensation exposure.

Follow the below instructions to help avoid condensation:

- Check the cubicles for any condensation. If any condensation is found, clean the cubicle and insulating components.
- Inspect the cubicle for sufficient ventilation and heating. If required, use dehumidification devices.
- Turn ON the heater for 2 to 3 hours prior to energizing the cubicle.

Corrosion Protection

Drive mechanisms and covers have a long-term protection against corrosion.

Any damage to the paint, scratches and other damage should be repaired immediately to help avoid corrosion.

Maintenance Specifications

The MCSeT series indoor switchgear units are designed for normal operating conditions in accordance with IEC 62271-1. Refer to *Safety Provisions*, page 10.

For details, it is recommended to contact our Schneider Electric service centre to help ensure correct functioning of the installation and maintenance.

After 6 to 12 months of operations, we recommend to check the busbars and MV cable connection tightening.

NOTE:

- Check the power connections like busbars, cable connections and fixed contacts with a calibrated torque spanner.
- Compare the values indicated and adjust if required. Refer to *Screw Fastenings*, page 36.

The elastic washers placed on the external sides of the connections and busbars helps to ensure better distribution of stress induced by the screw torque.

If no problems are detected, the busbars and cable connections are not modified, it is not necessary to do again this check. In case of dismantling, discard the removed elastic washers and install new elastic washers supplied by Schneider Electric.

Our service centre is at your disposal at any time:

- To undergo an installation diagnostic.
- To offer you, if need be, suitable maintenance operations.
- To offer you maintenance contracts.
- To offer you adaptations.

Inspection

DANGER

HAZARD OF ELECTRIC SHOCK, EXPLOSION OR ARC FLASH

In case of frequent condensation or air pollution (dust, smoke, or corrosive gases), the maintenance intervals must be adapted to the actual conditions.

Failure to follow these instructions will result in death or serious injury.

It is recommended to check the cubicles visually at regular intervals depending on the strain they are subject to during operation and in accordance with the national regulations.

A visual inspection includes a complete check of the cubicles by certified staff for contamination, condensation and damage.

Lubrication Instructions

NOTICE

HAZARD OF INAPPROPRIATE MAINTENANCE

The bearings and joints must not be washed out by the cleaning agent and following elements must not be lubricated:

- Ball bearings
- Auxiliary releases
- Push switches
- Auxiliary switches

Only approved lubricants may be used.

Failure to follow these instructions can result in equipment damage.

Preparation:

1. Remove the truck from the panel.
2. Clean lubrication points using a lint-free cloth, Refer to Figure 86.
NOTE: Use cleaning agent in case of serious contamination.
3. Use cleaning agents sparingly. Lubricating points only to be moistened. Refer to Auxiliary Products, page 37.

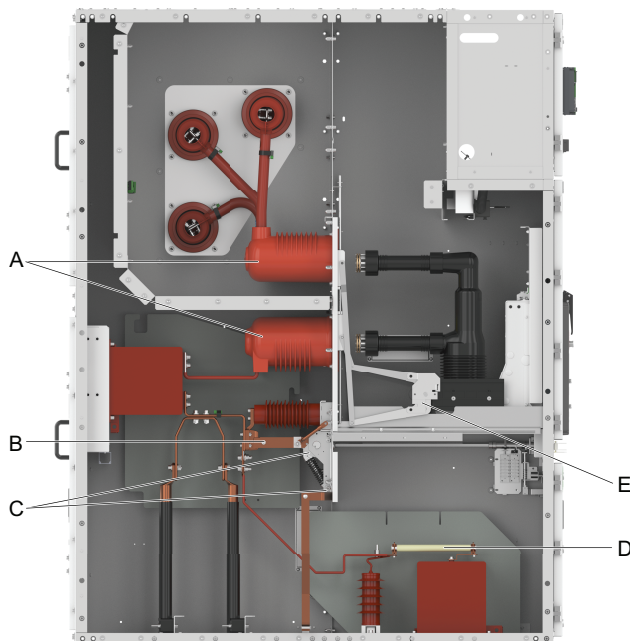

Figure 86
Lubrication points in the cubicle

- | | | | |
|---|-------------------------|---|-------------------|
| A | Fixed contacts | D | VT Fuse |
| B | E/S contacts | E | Shutter mechanism |
| C | E/S operating mechanism | | |

NOTE:

- The lubricants are provided by the manufacturer. The use of alternative lubricants is not permissible.
- The image shown here is for illustration purpose only.

Table 19 Details of Lubrication

Lubrication points	Lubricants	Lubrication procedure	Markers on the view
Sliding electrical contact surfaces	MOBILITH SHC 100 (red)	Apply a thin and uniform film of lubricant.	A, B
All accessible friction points and mechanical sliding surfaces	MOBILITH SHC 100 (red)	Clean lubrication points with lint free cotton cloth; apply a thin film of lubricant (for example, using a paintbrush).	C
All accessible friction points and mechanical sliding surfaces	ISOFLEX TOPAS L152 "KLUBER" (white)	Clean lubrication points with lint free cotton cloth; apply a thin film of lubricant (for example, using a paintbrush).	D, E

Once maintenance work is complete:

1. Remove all the tools and auxiliary equipment used.
2. Re-insert truck into the panel.
3. Reposition covers, close doors and check switching functions.

Treatment of Firmly Screw-Connected Contact Surfaces

▲ WARNING

HAZARD OF INAPPROPRIATE ASSEMBLY

- When handling bars insulated by heat-shrinkable sleeves, ensure that heat-shrinkable sleeve does not get in contact with lubricant to prevent swelling.
- Do not touch the contact areas coated with lubricant Mobilith SHC 100.

Failure to follow these instructions can result in death, serious injury, or equipment damage.

Follow the below steps for treatment of firmly screw-connected contact surfaces:

1. Before screw fastening, contact areas to be subjected to preliminary treatment.

Table 20 Pre-treatment for the Material of Contact Surfaces

Material of contact surfaces	Pre-treatment
Silver-plated contact surfaces	Clean ⁽¹⁾
Hot-galvanized sheet-metal	Clean ⁽¹⁾ , passivation need not be removed
Copper or copper alloy	Clean ⁽¹⁾ , expose metallic surface ⁽²⁾
Aluminium	Clean ⁽¹⁾ , expose metallic surface ⁽²⁾
Steel	Clean ⁽¹⁾ , expose metallic surface ⁽²⁾
Zinc-plated steel	Remove passivation, not the zinc layer ⁽³⁾
Nickel-plated contact surfaces	Remove passivation layer ⁽⁴⁾
<p>⁽¹⁾ Clean by means of lint-free cloth; use cleaning agent in case of serious contamination.</p> <p>⁽²⁾ Expose metallic surface</p> <ul style="list-style-type: none"> • by treating the entire surface with emery cloth or a rotating grinding tool (grain-size 100 or 80) or • using a wire brush which is clearly marked for use exclusively for aluminium or exclusively for copper. <p>⁽³⁾ Using a brass brush, steel brush.</p> <p>⁽⁴⁾ Rub slightly by hand using Scotchbrite abrasive agent (Ni layer must not be reduced).</p>	

PowerLogic PD100 Operation and Maintenance

Follow the below steps for operation and maintenance:

1. Remove the VCB compartment separation sheet.
2. Flip the PowerLogic PD100 enclosure box over the E/S operating box.
3. Do the maintenance in the busbar compartment.
4. Closure - To put back into operation, carry out operations in the reverse order.

Replacement of Components and Cubicles

Drive mechanisms, CT, VT, testing and monitoring systems, and complete switchgear cubicles can be replaced as required.

For any queries regarding, Replacement of components or cubicles contact the manufacturer service center with below informations.

- Type designation
- Serial number
- Year of construction

Glossary

A

AFL: Accessibility Front Lateral

AFLR: Accessibility Front Lateral Rear

B

BME: Busbar Metering and Earthing

BSC: Bus Section Coupler

BSR: Bus Section Riser

C

CT: Current Transformer

E

E/S: Earth Switch

EvoPacT HVX: Vacuum Circuit Breaker

EvoPacT MTX: Metering Truck

H

HMI: Human-Machine Interface

I

I/F: Incomer/Feeder

L

LV: Low Voltage

M

MV: Medium Voltage (voltage class up to 24 kV)

P

PowerLogic PD100: PowerLogic Partial Discharge100

V

VCB: Vacuum Circuit Breaker

VDIS: Voltage Detecting and Indicating System

VT: Voltage Transformer

Schneider Electric
35 rue Joseph Monier
92500 Rueil Malmaison
France

+ 33 (0) 1 41 29 70 00

www.se.com

As standards, specifications, and design change from time to time, please ask for confirmation of the information given in this publication.

© 2026 – Schneider Electric. All rights reserved.

BQT6904800 -03