

TeSys Active

TeSys Tera Motor Management System

Installation Guide

TeSys offers innovative and connected solutions for motor starters.

DOCA0356EN-01
11/2025



Legal Information

The information provided in this document contains general descriptions, technical characteristics and/or recommendations related to products/solutions.

This document is not intended as a substitute for a detailed study or operational and site-specific development or schematic plan. It is not to be used for determining suitability or reliability of the products/solutions for specific user applications. It is the duty of any such user to perform or have any professional expert of its choice (integrator, specifier or the like) perform the appropriate and comprehensive risk analysis, evaluation and testing of the products/solutions with respect to the relevant specific application or use thereof.

The Schneider Electric brand and any trademarks of Schneider Electric SE and its subsidiaries referred to in this document are the property of Schneider Electric SE or its subsidiaries. All other brands may be trademarks of their respective owner.

This document and its content are protected under applicable copyright laws and provided for informative use only. No part of this document may be reproduced or transmitted in any form or by any means (electronic, mechanical, photocopying, recording, or otherwise), for any purpose, without the prior written permission of Schneider Electric.

Schneider Electric does not grant any right or license for commercial use of the document or its content, except for a non-exclusive and personal license to consult it on an "as is" basis.

Schneider Electric reserves the right to make changes or updates with respect to or in the content of this document or the format thereof, at any time without notice.

To the extent permitted by applicable law, no responsibility or liability is assumed by Schneider Electric and its subsidiaries for any errors or omissions in the informational content of this document, as well as any non-intended use or misuse of the content thereof.

Table of Contents

Safety Information.....	5
About the Document.....	6
Precautions.....	11
Introduction of the TeSys Tera Motor Management System.....	13
TeSys Master Range.....	14
TeSys Tera System.....	15
Technical Characteristics	18
Installation of the TeSys Tera Motor Management System	20
General Principles	21
Dimensions of TeSys Tera System	23
Overview.....	24
LTMT Main Unit	24
LTMTCT/LTMTCTV Sensor Module	25
LTMT Expansion Module.....	26
Clearance Zone Dimensions.....	27
LTMTCUF Control Operator Unit.....	28
Unboxing Guidelines.....	29
Unboxing Guidelines.....	30
Mounting of TeSys Tera System on the DIN Rail.....	33
LTMT Main Unit Mounting.....	34
LTMTCT••T/LTMTCTV••T Horizontal Sensor Module Mounting	37
LTMT Expansion Module Mounting	40
LTMTCUF Control Operator Unit Mounting	43
Assembly.....	47
Assembling LTMT Main Unit on LTMTCT/LTMTCTV Horizontal Sensor Module	48
Component Interconnection	49
Connection Cables.....	50
Connection of LTMT Main Unit to LTMTCT/LTMTCTV Horizontal Sensor Module	51
Connection of LTMT Main Unit to LTMT Expansion Module.....	53
Connection of the LTMT Main Unit to PC	54
Connection of LTMT Main Unit to LTMTCUF Control Operator Unit.....	55
Wiring of the TeSys Tera Motor Management System	57
Wiring Guidelines	58
Screw Terminal Connectors.....	59
LTMT Main Unit Wiring.....	60
LTMTCT/LTMTCTV Sensor Module Wiring.....	75
LTMT Expansion Module Wiring	84
4 Digital Inputs and 2 Digital Outputs (4DI+2DO) LTMT Expansion Module.....	85
2 Analog Inputs and 1 Analog Output (2AI+1AO) Expansion Module	87
Additional Wiring Instructions	89
Power Supply Wiring.....	90
Digital Inputs Wiring	92

Digital Outputs Wiring.....	97
Commissioning	98
Introduction.....	99
First Power-up of the LTMT Main Unit (Control Circuit)	101
First Setup Parameters	102
Additional Parameters.....	104
Verifying System Wiring	105
Verify Configuration	108
First Motor Power-up	109
Maintenance	110
Detecting Problems	112
Troubleshooting	115
Preventive Maintenance.....	116
Replacing LTMT Main Unit, LTMTCT/LTMTCTV Sensor Module, and LTMT Expansion Module.....	120
Communication Alarms and Trips	122

Safety Information

Important Information

Read these instructions carefully, and look at the equipment to become familiar with the device before trying to install, operate, service, or maintain it. The following special messages may appear throughout this documentation or on the equipment to warn of potential hazards or to call attention to information that clarifies or simplifies a procedure.



The addition of this symbol to a “Danger” or “Warning” safety label indicates that an electrical hazard exists which will result in personal injury if the instructions are not followed.



This is the safety alert symbol. It is used to alert you to potential personal injury hazards. Obey all safety messages that follow this symbol to avoid possible injury or death.

DANGER

DANGER indicates a hazardous situation which, if not avoided, **will result in** death or serious injury.

WARNING

WARNING indicates a hazardous situation which, if not avoided, **could result in** death or serious injury.

CAUTION

CAUTION indicates a hazardous situation which, if not avoided, **could result in** minor or moderate injury.

NOTICE

NOTICE is used to address practices not related to physical injury.

Please Note

Electrical equipment should be installed, operated, serviced, and maintained only by qualified personnel. No responsibility is assumed by Schneider Electric for any consequences arising out of the use of this material.

A qualified person is one who has skills and knowledge related to the construction and operation of electrical equipment and its installation, and has received safety training to recognize and avoid the hazards involved.

About the Document

Document Scope

This document provides complete information necessary to install, commission, and maintain the TeSys™ Tera system which includes:

- LTMT main unit
- LTMTCT/LTMTCTV sensor module
- LTMT expansion module
- LTMTCUF control operator unit

The purpose of this guide is to:

- Familiarize yourself with the mechanical and electrical characteristics of the TeSys Tera system components.
- Describe how to assemble and wire the TeSys Tera system and its components.
- Describe how to commission and maintain the TeSys Tera system.

This guide is intended for:

- Design engineers
- Panel builders
- System integrators
- Maintenance engineers

Validity Note

This document is valid for the following certified components of the TeSys Tera system:

Commercial Reference	Description	Range
LTMTEFM	LTMT main unit with EtherNet/IP or Modbus TCP/IP protocol	100–240 Vac/Vdc
LTMTEBD	LTMT main unit with EtherNet/IP or Modbus TCP/IP protocol	24 Vdc
LTMTMFM	LTMT main unit with Modbus RTU protocol	100–240 Vac/Vdc
LTMTMBD	LTMT main unit with Modbus RTU protocol	24 Vdc
LTMTPFM	LTMT main unit with PROFIBUS DP protocol	100–240 Vac/Vdc
LTMTPBD	LTMT main unit with PROFIBUS DP protocol	24 Vdc
LTMTCT3T	LTMT horizontal sensor module with current transformer	Current range = 0.3–3 A
LTMTCT25T	LTMT horizontal sensor module with current transformer	Current range = 2.5–25 A
LTMTCT100T	LTMT horizontal sensor module with current transformer	Current range = 10–100 A
LTMTCTV3T	LTMT horizontal sensor module with current and voltage transformers	<ul style="list-style-type: none"> • Current range = 0.3–3 A • Voltage range = 60–690 Vac

LTMTCTV25T	LTMT horizontal sensor module with current and voltage transformers	<ul style="list-style-type: none"> Current range = 2.5–25 A Voltage range = 60–690 Vac
LTMTCTV100T	LTMT horizontal sensor module with current and voltage transformers	<ul style="list-style-type: none"> Current range = 10–100 A Voltage range = 60–690 Vac
LTMTCTV3UT	LTMT horizontal sensor module with current and voltage transformers	<ul style="list-style-type: none"> Current range = 0.3–3 A Voltage range = 60–600 Vac
LTMTCTV25UT	LTMT horizontal sensor module with current and voltage transformers	<ul style="list-style-type: none"> Current range = 2.5–25 A Voltage range = 60–600 Vac
LTMTCTV100UT	LTMT horizontal sensor module with current and voltage transformers	<ul style="list-style-type: none"> Current range = 10–100 A Voltage range = 60–600 Vac
LTMTIN42FM	LTMT expansion module with four digital inputs and two digital outputs	<ul style="list-style-type: none"> 100–265 Vac/dc for IEC 110–240 Vac/dc for UL
LTMTIN42BD	LTMT expansion module with four digital inputs and two digital outputs	24 Vdc
LTMTAN21	LTMT expansion module with two analog inputs and one analog output	4–20 mA
LTMT9RJ1015	LTMT main unit to LTMTCT/ LTMTCTV sensor module RJ11 connector cable	0.15 m (5.9 in) in length
LTMT9RJ401	LTMT main unit to LTMT expansion module RJ45 connector cable	0.1 m (3.9 in) in length
LTMT9RJ105	LTMT main unit to LTMTCT/ LTMTCTV sensor module RJ11 connector cable	0.5 m (19.6 in) in length
LTMTCUF	LTMTCUF control operator unit	–
LTMT9RJ102	LTMT main unit to LTMTCT/ LTMTCTV sensor module cable	0.2 m (7.874 in) in length
LTMT9EX10	LTMT main unit to LTMT expansion module cable	1 m (39.37 in) in length
LTMT9CU10S	LTMT main unit to LTMTCUF control operator unit	1 m (39.37 in) in length
LTMT9CU30S	LTMT main unit to LTMTCUF control operator unit	3 m (118.11 in) in length

The availability of some functions described in this document depends on the communication protocol used and the physical modules installed on the TeSys Tera system.

General Cybersecurity Information

In recent years, the growing number of networked machines and production plants has seen a corresponding increase in the potential for cyber threats, such as unauthorized access, data breaches, and operational disruptions. You must, therefore, consider all possible cybersecurity measures to help protect assets and systems against such threats.

To help keep your Schneider Electric products secure and protected, it is in your best interest to implement the cybersecurity best practices as described in the [Cybersecurity Best Practices](#) document.

Schneider Electric provides additional information and assistance:

- [Subscribe to the Schneider Electric security newsletter.](#)
- [Visit the Cybersecurity Support Portal web page to:](#)
 - [Find Security Notifications.](#)
 - [Report vulnerabilities and incidents.](#)
- [Visit the Schneider Electric Cybersecurity and Data Protection Posture web page to:](#)
 - [Access the cybersecurity posture.](#)
 - [Learn more about cybersecurity in the cybersecurity academy.](#)
 - [Explore the cybersecurity services from Schneider Electric.](#)

Product Related Cybersecurity Information

Refer to *TeSys Tera Motor Management System Cybersecurity Guide – DOCA0260***, page 9.

Environmental Data

For product compliance and environmental information, refer to the Schneider Electric Environmental Data Program.

Available Languages of the Document

The document is available in these languages:

- English
- Chinese
- French
- German
- Italian
- Korean
- Spanish

Related Documents

Title of documentation	Description	Reference number
TeSys Tera Motor Management System Catalog	The catalog <ul style="list-style-type: none"> • Describes the TeSys Tera system • Contains the TeSys Tera technical characteristics 	LVCATENTER
TeSys Tera Motor Management System User Guide	This is the main user guide that introduces the complete TeSys Tera system. It describes the main functions of the LTMT main units, LTMTCT/LTMTCTV sensor modules, LTMT expansion modules, and LTMTCUF control operator unit.	DOCA0257EN DOCA0257FR DOCA0257ES DOCA0257DE DOCA0257IT DOCA0257ZH-CN DOCA0257KO
TeSys Tera Motor Management System Modbus RTU Communication Guide	This guide describes the Modbus network protocol communication of the LTMT main unit.	DOCA0355EN DOCA0355FR DOCA0355ES DOCA0355DE DOCA0355IT DOCA0355ZH-CN DOCA0355KO
TeSys Tera Motor Management System PROFIBUS DP Communication Guide	This guide describes the PROFIBUS DP network protocol communication of the LTMT main unit.	DOCA0256EN DOCA0256FR DOCA0256ES DOCA0256DE DOCA0256IT DOCA0256ZH-CN DOCA0256KO
TeSys Tera Motor Management System EtherNet/IP Communication Guide	This guide describes the EtherNet/IP network protocol communication of the LTMT main unit.	DOCA0258EN DOCA0258FR DOCA0258ES DOCA0258DE DOCA0258IT DOCA0258ZH-CN DOCA0258KO
TeSys Tera Motor Management System LTMTCUF control operator unit User Guide	This guide describes how to install, configure, and use the LTMTCUF control operator unit.	DOCA0233EN DOCA0233FR DOCA0233ES DOCA0233DE DOCA0233IT DOCA0233ZH-CN DOCA0233KO

Title of documentation	Description	Reference number
TeSys Tera Motor Management System DTM library Online Help Guide	This guide describes the TeSys Tera DTM Library which allows the customization of the control functions of the TeSys Tera Motor Management System.	DOCA0275EN DOCA0275FR DOCA0275ES DOCA0275DE DOCA0275IT DOCA0275ZH-CN DOCA0275KO
TeSys Tera Motor Management System DTM library Software Release Notes	This document provides important information about the TeSys Tera DTM Library software and provides summary of new features and enhancement.	DOCA0279EN DOCA0279FR DOCA0279ES DOCA0279DE DOCA0279IT DOCA0279ZH-CN DOCA0279KO
TeSys Tera Motor Management System Firmware Release Notes	This guide provides important information about the TeSys Tera system firmware packages and provides summary of new features and enhancement.	DOCA0276EN DOCA0276FR DOCA0276ES DOCA0276DE DOCA0276IT DOCA0276ZH-CN DOCA0276KO
TeSys Tera Motor Management System Cybersecurity Guide	This guide provides information on cybersecurity aspects for the TeSys Tera Motor Management System. This guide addresses on how to secure your operational technology network, or your company serial or Ethernet network.	DOCA0260EN DOCA0260FR DOCA0260ES DOCA0260DE DOCA0260IT DOCA0260ZH-CN DOCA0260KO

To find documents online, visit the Schneider Electric download center www.se.com/ww/en/download/.

Information on Non-Inclusive or Insensitive Terminology

As a responsible, inclusive company, Schneider Electric is constantly updating its communications and products that contain non-inclusive or insensitive terminology. However, despite these efforts, our content may still contain terms that are deemed inappropriate by some customers.

Trademarks

QR Code is a registered trademark of DENSO WAVE INCORPORATED in Japan and other countries.

Precautions

Read and understand the following precautions before performing any procedures in this guide.

⚡⚠ DANGER

HAZARD OF ELECTRIC SHOCK, EXPLOSION, OR ARC FLASH

- This equipment must only be installed and serviced by qualified electrical personnel.
- Turn off all power supplying to this equipment before working on this equipment.
- Use only the specified voltage when operating this equipment and any associated products.
- Always use a properly rated voltage sensing device to confirm power is off.
- Use appropriate interlocks where personnel and/or equipment hazards exist.
- Power line circuits must be wired and protected in compliance with local and national regulatory requirements.
- Apply appropriate personal protective equipment (PPE) and follow safe electrical work practices per NFPA 70E, NOM-029-STPS, or CSA Z462 or local equivalent.

Failure to follow these instructions will result in death or serious injury.

⚠ WARNING

UNINTENDED EQUIPMENT OPERATION

- Do not disassemble, repair, or modify this equipment. There are no user serviceable parts.
- Install and operate this equipment in an enclosure appropriately rated for its intended application environment.
- Each implementation of this equipment must be individually and thoroughly tested for proper operation before being placed into service.

Failure to follow these instructions can result in death, serious injury, or equipment damage.

California Proposition 65 Warning



WARNING: This product can expose you to chemicals such as, Humiseal 1A33 Polyurethane, which is known to the State of California to cause cancer and birth defects or other reproductive harm. For more information go to www.P65Warnings.ca.gov.

Qualified Personnel

Only appropriately trained personnel who are familiar with and understand the content of this guide and all other related product documentation are authorized to work on and with this product.

The qualified personnel must be able to detect possible hazards that may arise from modifying parameter values and generally from mechanical, electrical, or electronic equipment. The qualified personnel must be familiar with the standards, provisions, and regulations for the prevention of industrial accidents, which they must observe when designing and implementing the system.

The use and application of the information contained in this guide requires expertise in the design and programming of automated control systems. Only you,

the user, panel builder, or integrator, can be aware of all the conditions and factors present during installation, setup, operation, and maintenance of a process plant or machine, and can therefore determine the automation and associated equipment and the related safeties and interlocks which can be effectively and properly used when selecting automation and control equipment, and any other related equipment or software, for a particular application. You must also consider applicable local, regional, or national standards and/or regulations.

Pay particular attention to conformance with any safety information, electrical requirements, and normative standards that apply to your process plant or machine in the use of this equipment.

Intended Use

The products described in this guide, together with software, accessories, and options, are a part of starters for low-voltage electrical loads, intended for industrial use according to the instructions, directions, examples, and safety information contained in the present document and other supporting documentation.

The product may only be used in compliance with all applicable safety regulations and directives, the specified requirements, and the technical data.

Before using the product, you must perform a risk assessment of the planned application. Based on the results, appropriate safety-related measures must be implemented.

Since the product is used as a component of a process plant or machine, you must ensure the safety of personnel by means of the overall system design.

Operate the product only with the specified cables and accessories. Use only genuine accessories and spare parts.

Any use other than the use explicitly permitted is prohibited and can result in unanticipated hazards.

Introduction of the TeSys Tera Motor Management System

What's in This Part

TeSys Master Range 14
TeSys Tera System..... 15
Technical Characteristics 18

TeSys Master Range

TeSys is an innovative motor control, monitoring, and management solution from the global market leader. TeSys offers connected, efficient products, solutions for switching, protection of motors, and electrical loads in compliance with all major global electrical standards.

TeSys Tera System

Overview

The TeSys Tera Motor Management System (TeSys Tera system) is part of the TeSys Active range of intelligent relays and motor starters. The TeSys Tera system is designed as a reliable building block for Intelligent Motor Control Centres (iMCCs) to provide complete protection, control, metering, and monitoring capabilities for single-phase or three-phase AC induction motors.

The TeSys Tera system is installed in the low voltage switchgear system and connects the higher level automation system through fieldbus network and the motor feeder.

TeSys Tera system:

- Covers conventional and advanced motor protection, metering, and monitoring in iMCC feeders into single, easy to configure, compact communicating module with a standalone HMI device.
- Provides protection controller for low voltage contactor-controlled motor starter feeders.
- Provides flexible and modular motor management system for motors with constant speeds in low voltage applications.

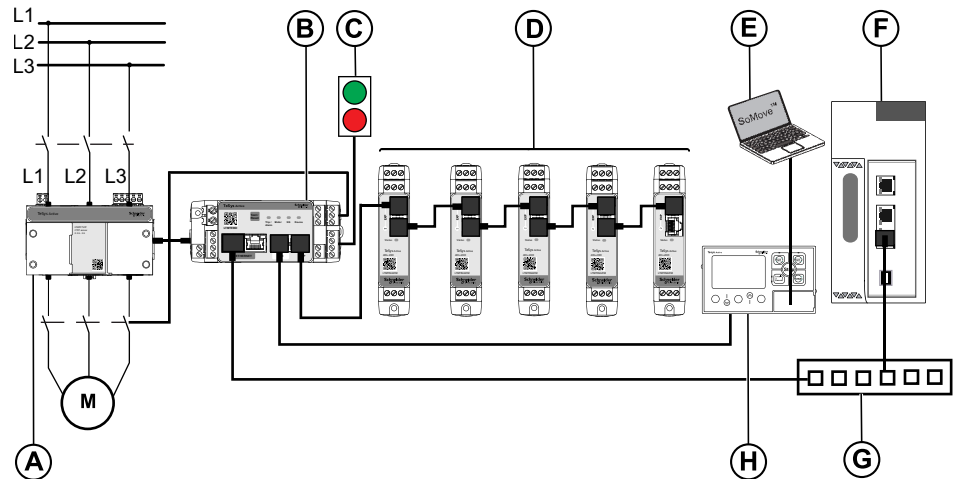

- A LTMTCT/LTMTCTV sensor module
- B LTMT main unit
- C Start/Stop commands
- D LTMT expansion modules
- E PC running SoMove FDT container software with TeSys Tera DTM installed
- F Programmable Logic Controller (PLC) or Distributed Control System (DCS)
- G Ethernet switch
- H LTMTCUF control operator unit

Functional Characteristics

The TeSys Tera system manages:

- Single-phase or three-phase AC induction motors and heaters rated up to 100 A and 690 V operational voltage, with an integral sensor module.
- Single-phase or three-phase AC induction motors and heaters rated up to 810 A and 690 V operational voltage, with external current transformers.

- The connection between the control system and the motor feeder, increases plant availability.
- Significant savings to the installation, commissioning, operation, and maintenance.
- Numerical microprocessor equipped controller that allows to set parameters of the motor according to the application and process requirements.

Key Benefits

The key benefits with use of advanced motor protection are:

- The TeSys Tera system covers all the load to monitor and protect the needs from the feeders to the critical process automation.
- The equipment is protected when advanced diagnostics, statistics, and alarms helps to anticipate unexpected production halts and minimize downtime.
- The TeSys Tera system is compact and a natural fit for the control panels with IEC or NEMA standards.
- The TeSys Tera system connectivity and access to real-time data provide key information to enhance the operation and safety of the process while improving efficiency.

Features

The TeSys Tera system provides the following features:

- Configurable overload protection for class 5 to 40 based on current.
- Thermistor based motor protection.
- Imbalance, phase loss protection for current and voltage input separately.
- Locked rotor and stalled rotor protection.
- Electrical parameter monitoring, such as current, voltage, power, power factor, harmonics, and energy.
- Monitoring for different motor based parameters, such as operating hours, number of starts, run hours, and thermal memory.
- TeSys Tera system can be used for motor and heater load application.
- Communication with PLC or DCS over EtherNet/IP, Modbus TCP/IP, Modbus RTU, or PROFIBUS DP protocol.
- Records trip data, event, and self-diagnostic events with time stamp.
- Different starter configurations, such as overload, direct online (DOL), reverse direct online (RDOL), star delta and single-phase motor application.
- Independent protection, even if PLC or DCS connection is interrupted, TeSys Tera system still provides protection for the motor.
- Flexible protection, control, and communication options to suit any low voltage contactor-controlled motor starter application.
- Integrated push button and LED indicators reduce external components and wiring.
- Multiple communication protocols allow affordable integration to larger and complex substation monitoring and control systems.
- Reset push button is available on the LTMT main unit and the LTMTCUF control operator unit thereby reducing the need for one digital input to be configured as reset.
- Optional graphical control operator unit is provided with the LTMT main unit for display of all metering, protection, and configuring parameters.

- Conformal coating on the PCB inside the controller resists the corrosive environment, hazardous chemicals, dust, and so on.

Supported Industries

The TeSys Tera system supports the following industries and associated business sectors:

Industry	Sectors	Application
Industry	<ul style="list-style-type: none"> • Metal, mineral, mining, cement, glass, steel, paper, gold, diamond, and platinum • Petrochemical • Chemical, pulp, and paper industry • Pharmaceutical • Oil and gas 	<ul style="list-style-type: none"> • Control and monitor pump motors • Control ventilation • Control load traction and movements • View status and communicate with machines • Process and communicate the data captured • Remotely manage data for one or several sites through the internet
Energy and Infrastructure	<ul style="list-style-type: none"> • Water treatment and transportation • Power generation and transport 	<ul style="list-style-type: none"> • Control and monitor pump motors • Control ventilation • Remotely control wind turbine • Remotely manage data for one or several sites through the internet
Motor Control Centre (MCC)	<ul style="list-style-type: none"> • Process industry • Power plant engineering 	<p>Protection and control of motors:</p> <ul style="list-style-type: none"> • Heavy starting motors (paper, cement and metal industries, and water managements) • High availability plants (chemical, oil, raw material, processing industry, and power plants)

Technical Characteristics

Environmental Characteristics

Conforming to standards	IEC/EN 60947-4-1, UL/CSA 60947-4-1	
Product certifications	IEC, UL ⁽¹⁾	
Rated insulation voltage (Ui)	Conforming to IEC/EN 60947-1, overvoltage category III, degree of pollution 3	690 V
Rated impulse withstand voltage (Uimp)	Conforming to IEC/EN 60947-4-1	
	100–240 Vac/Vdc supply, digital inputs and digital outputs	4 kV
	24 Vdc supply, inputs, and outputs	0.8 kV
	Communication circuits	0.8 kV
	Current or voltage measurement circuit	6 kV
Short-circuit withstand	Conforming to IEC/EN 60947-4-1	100 kA
Climatic withstand	Conforming to IEC/EN 60068-2-30	12 x 24 hour cycles
	Conforming to IEC/EN 60070-2-11	48 h
Corrosion immunity	Atmosphere free from corrosive gases	
Humidity	Non-condensing	5–95%
Ambient air temperature around the device	Storage	-40 to +80 °C (-40 to +176 °F)
	Operation	-20 to +70 °C (-4 to +158 °F)
Measured creepage distances	-	<ul style="list-style-type: none"> • 5.10 mm (0.20 in.) on 250 V • 7.16 mm (0.28 in.) on 600 V
Flame resistance	Conforming to UL 94	960 °C (1760 °F) (for parts supporting live components)
	Conforming to IEC/EN 60695-2-12	650 °C (1202 °F) (for other parts)
Shock resistance ⁽²⁾ (1/2 sine wave, 11 ms)	Conforming to IEC/EN 60068-2-27	15 gn
Vibration resistance ⁽²⁾	Conforming to IEC/EN 60068-2-6	4 gn (plate mounted)
	5–300 Hz	1 gn (mounted on DIN rail)
Resistance to electrostatic discharge	Conforming to IEC/EN 61000-4-2	In open air: 8 kV - Level 3 On contact: 6 kV - Level 3
Immunity to radiated electromagnetic interference	Conforming to IEC 61000-4-3	10 V/m - Level 3
Immunity to fast transient	Conforming to IEC 61000-4-4	On supply and digital outputs: 2 kV - Level 3 Other circuits: 2 kV on other circuits (LTMT expansion module DI and DO)
Immunity to radioelectric fields ⁽³⁾	Conforming to IEC/EN 61000-4-6	10 V - Level 3

(1) This product has been designed for use in certified environment, else it may cause unwanted electromagnetic disturbance to self or other devices.

(2) Without modifying the contact states, in the most unfavorable direction.

(3) This product has been designed for use in environment A and in B, it may cause unwanted electromagnetic disturbance to self or other devices, which may require the implementation of adequate mitigation measures.

Immunity to Dissipated Shock Waves

Conforming to IEC/EN 61000-4-5		
	Common mode	Serial mode
Digital outputs and supply	4 kV	2 kV
24 Vdc digital inputs	2 kV	1 kV
100–240 Vac/Vdc digital inputs	2 kV	1 kV
Voltage inputs	4 kV	2 kV
Communication	2 kV	–
Temperature sensor (IT1/IT2)	Common mode is not applicable for LTMT main unit temperature sensor	1 kV-- Differential sensor

Altitude Derating

	2000 m (6562 ft)	3000 m (9843 ft)	3500 m (11483 ft)	4000 m (13123 ft)	4500 m (14764 ft)
Rated operational voltage (Ue)	1	0.93	0.87	0.8	0.7
Maximum operating temperature	1	0.93	0.92	0.9	0.88

Installation of the Tesys Tera Motor Management System

What's in This Part

General Principles	21
Dimensions of TeSys Tera System.....	23
Unboxing Guidelines	29
Mounting of TeSys Tera System on the DIN Rail	33
Assembly.....	47
Component Interconnection	49

General Principles

Safety Instructions

DANGER

HAZARD OF ELECTRIC SHOCK, EXPLOSION, OR ARC FLASH

- Turn off all power supplying this equipment before working on it.
- Apply appropriate personal protective equipment (PPE) and follow safe electrical work practices.

Failure to follow these instructions will result in death or serious injury.

WARNING

UNINTENDED EQUIPMENT OPERATION

- The application of this product requires expertise in the design and programming of control systems. Only personnel with such expertise should be allowed to program and apply this product.
- Follow all local and national safety codes and standards.
- Follow all electromagnetic compatibility guidelines described in this guide.
- Follow all installation and wiring guidelines described in this guide.

Failure to follow these instructions can result in death, serious injury, or equipment damage.

Introduction to Functional Safety

The TeSys Tera Motor Management System is a part of a global architecture. To provide the function safety, some risks must be analyzed such as:

- Global function risks: Thermal overload, Protection function risks, and so on.
- Risk of hardware and software breakdown.
- Electromagnetic environmental risks.

To reduce the electromagnetic environment risks, installation guidelines and wiring must be respected.

For more information, refer to the Electromagnetic Compatibility (EMC) chapter in the *Electrical Installation Guide* (Wiki version available in English only on www.electrical-installation.org).

Installation Guidelines

Installation guidelines must be respected to enable the LTMT main unit to operate correctly. This includes:

- Installation guidelines for the components:
 - Association of the LTMT main unit with the LTMTCT/LTMTCTV sensor module and optional LTMT expansion module.
 - Installation in a switchboard such as Okken, BlokSeT, and Model 6.
- Communication network wiring guidelines.

Installation Rules in a Switchboard

The installation of the LTMT main unit in the withdrawable drawer of a switchboard presents constraints specific to the type of switchboard:

- For installation of the LTMT main unit in a Schneider Electric Okken switchboard, refer to the *Okken Communications Cabling and Wiring Guide* (available on request).
- For installation of the LTMT main unit in a Schneider Electric BlokSeT switchboard, refer to the *BlokSeT Communications Cabling and Wiring Guide* (available on request).
- For installation of the LTMT main unit in a Schneider Electric Model 6 switchboard, refer to the *Model 6 Communications Cabling and Wiring Guide* (available on request).
- For installation of the LTMT main unit in other types of switchboard, follow the specific EMC instructions described in this guide and refer to the relative instructions specific to your type of switchboard.

Dimensions of TeSys Tera System

What's in This Chapter

Overview	24
LTMT Main Unit.....	24
LTMTCT/LTMTCTV Sensor Module	25
LTMT Expansion Module	26
Clearance Zone Dimensions	27
LTMTCUF Control Operator Unit	28

Overview

This section presents the dimensions of the LTMT main unit, LTMTCT/LTMTCTV sensor module, LTMT expansion module, and LTMTCUF control operator unit, as well as the dimensions of the clearance zone around the modules.

Dimensions are given in both millimeters and inches and applies to all the modules of TeSys Tera system.

LTMT Main Unit

The dimensions of the LTMT main unit are shown below:

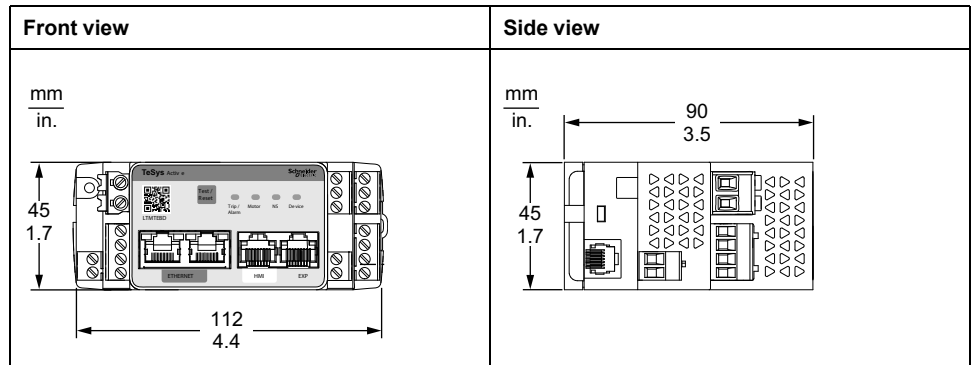

NOTE: The dimensions are same for all types of LTMT main unit.

LTMT Main Unit Mounted on LTMTCT/LTMTCTV Horizontal Sensor Module

The dimension of the LTMTCT••T/LTMTCTV••T horizontal sensor module with LTMT main unit mounted horizontally is shown below:

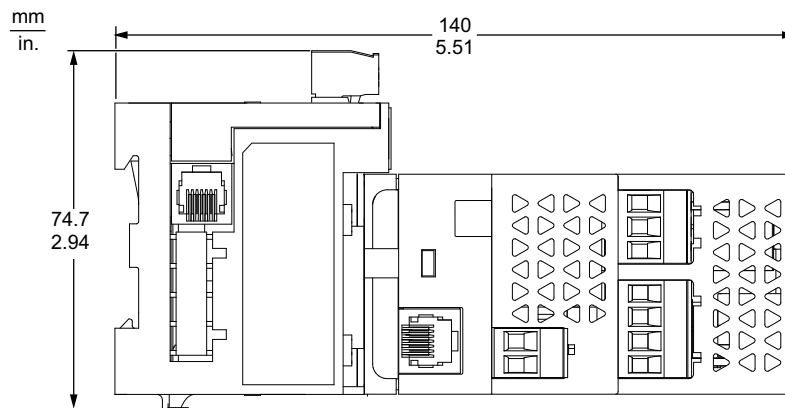

LTMTCT/LTMTCTV Sensor Module

LTMTCT••T/LTMTCTV••T Horizontal Sensor Module for IEC Application

The dimension of the LTMTCT••T/LTMTCTV••T horizontal sensor module for IEC applications is shown below:

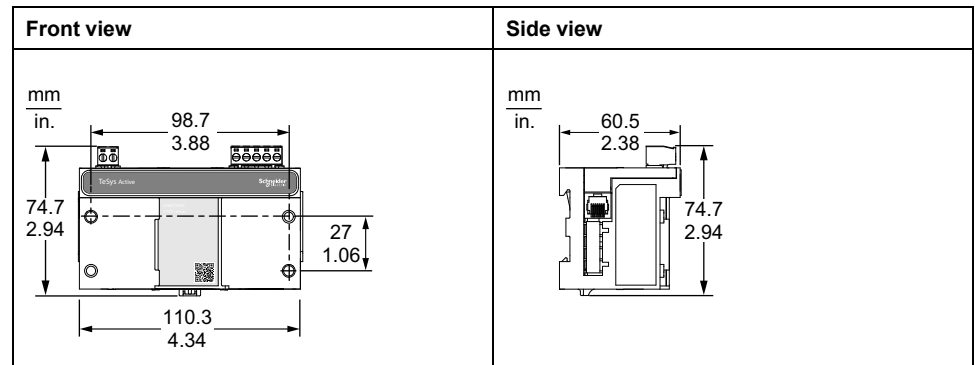

LTMTCTV••UT Horizontal Sensor Module for Side Connector Applications

The dimension of the LTMTCTV••UT horizontal sensor module for side connector applications is shown below:

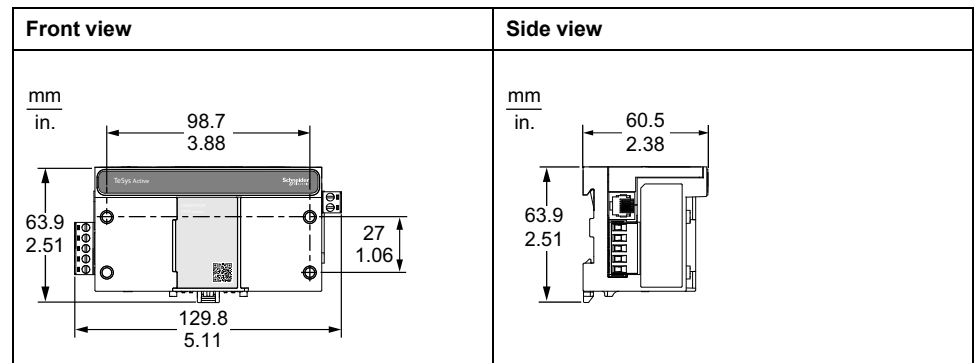

LTMT Expansion Module

The dimension of the LTMT expansion module is shown below:

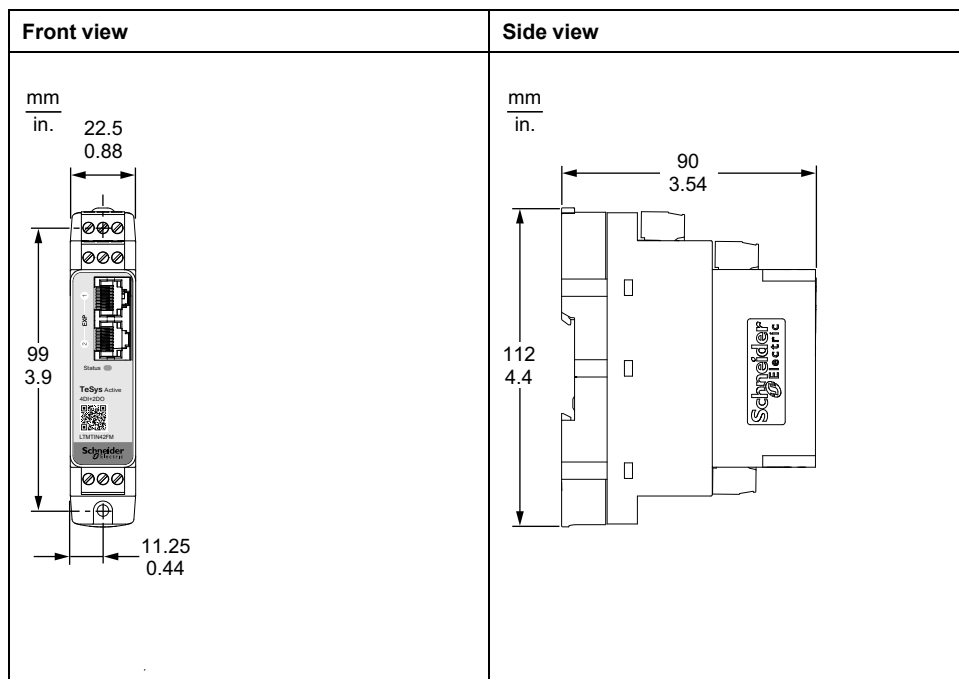

NOTE: The dimensions are same for all types of LTMT expansion module.

Clearance Zone Dimensions

For Electromagnetic Compatibility (EMC), it is recommended to mount a contactor at a distance of more than 100 mm (3.93 in) from the LTMT main unit and LTMT expansion module.

The clearance dimension of contactor from LTMT main unit and LTMT expansion module are shown below:

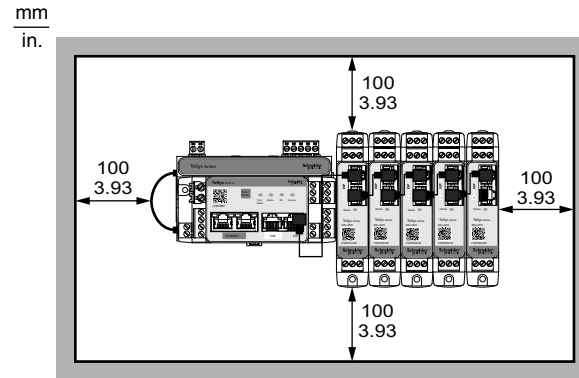

For more information on clearance dimension, refer to the *Okken and BlokSeT Communications Cabling and Wiring Guide* (available on request).

LTMTCUF Control Operator Unit

The dimension of the LTMTCUF control operator unit is shown below:

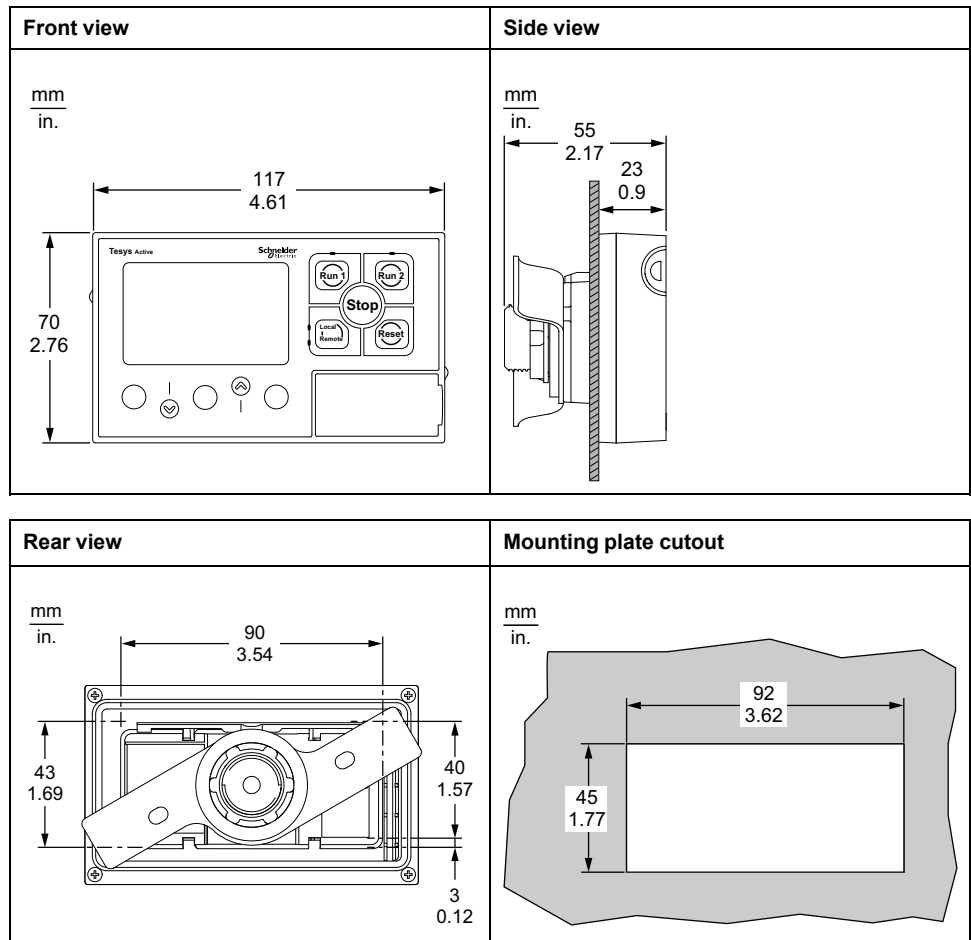

Unboxing Guidelines

What's in This Chapter

Unboxing Guidelines	30
---------------------------	----

Unboxing Guidelines

Opening the Box

The box contains the TeSys Tera modules and their respective accessories which are shown in the below image.

1. Modules: LTMT main unit, LTMTCT/LTMTCTV sensor module, LTMT expansion module, LTMTCUF control operator unit, and cables.
2. Light Instruction Sheet

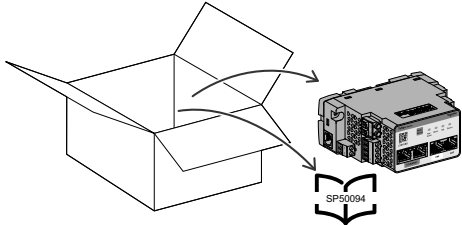
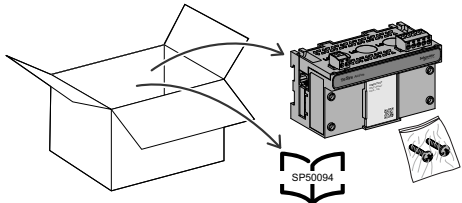
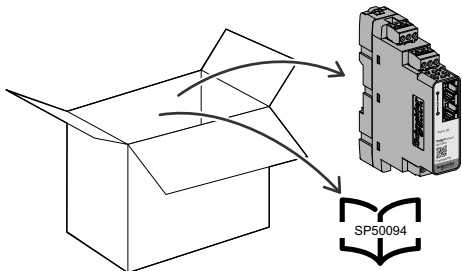
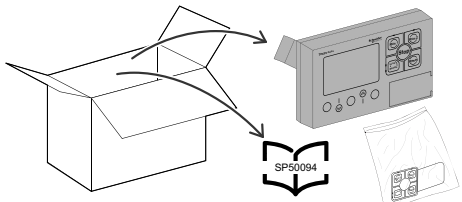
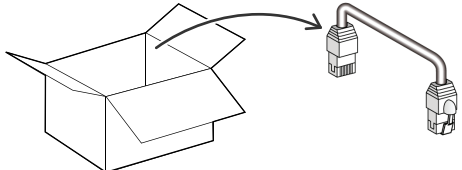
Modules and Cables	In the Box
LTMT main unit	
LTMTCT/LTMTCTV sensor module The box also contains two screws for mounting the LTMT main unit on top of the sensor module.	
LTMT expansion module	
LTMTCUF control operator unit	
LTMT main unit to LTMTCT/LTMTCTV sensor module RJ11 connector cable	

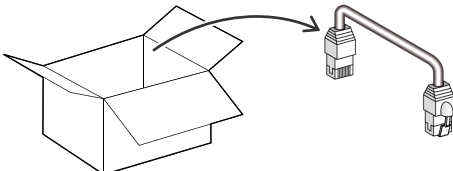
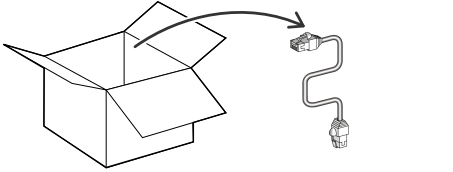
<p>LTMT main unit to LTMT expansion module RJ45 connector cable</p>	
<p>LTMT main unit to LTMT CUF control operator unit RJ45 connection cable</p>	

Peelable Label Instructions

The peelable label is on the front face of the LTMT main unit.



1. Read the following instructions printed on the label before removing it:

<p>⚠ WARNING</p>
<p>UNINTENDED EQUIPMENT OPERATION</p> <ul style="list-style-type: none"> • Ensure the DO contacts of the LTMT main unit are set to the Normally Open (NO) position using a multi meter. • Ensure to provide auxiliary power supply to the LTMT main unit before applying the motor control voltage. <p>Failure to follow these instructions can result in death, serious injury, or equipment damage.</p>

NOTE: Turn ON the power module to set DO in NO condition, when there is no load connected.

2. The following table represents the normal state for the DO contacts:

Terminal Details	Expected State
Verify between O3 NO and O3 C2	NO
Verify between O3 NC and O3 C2	NC
Verify between O1 13 and C1 14	NO
Verify between O2 23 and C1 14	NO

If any of the above mentioned state do not match, power on the relay and verify that the contact outputs correspond to the specified state.

3. To remove the peelable label, hold the notch provided and peel the label off the LTMT main unit

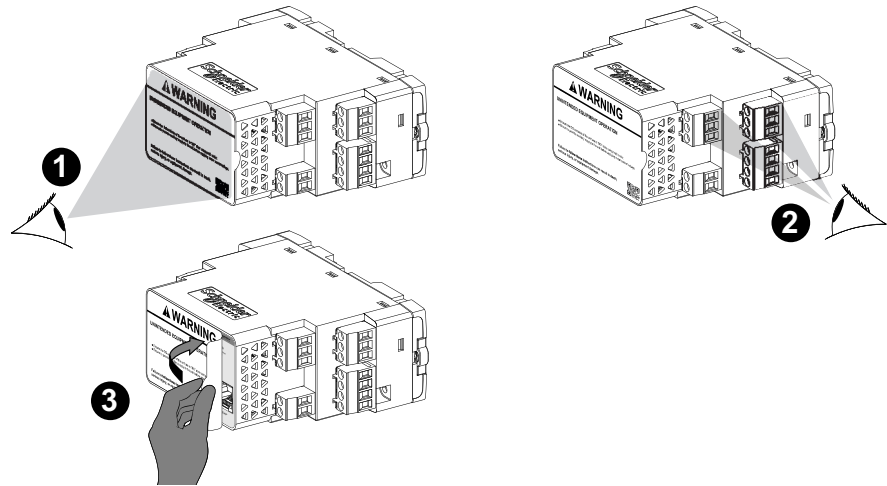

Mounting of TeSys Tera System on the DIN Rail

What's in This Chapter

LTMT Main Unit Mounting	34
LTMTCT••T/LTMTCTV••T Horizontal Sensor Module Mounting	37
LTMT Expansion Module Mounting	40
LTMTCUF Control Operator Unit Mounting	43

LTMT Main Unit Mounting

Mounting on DIN Rail

Mount the LTMT main unit on a 35 mm (1.38 in.) DIN rail with a thickness of 1.35 mm (0.05 in.) and 0.75 mm (0.02 in.).

To mount the LTMT main unit proceed as follows:

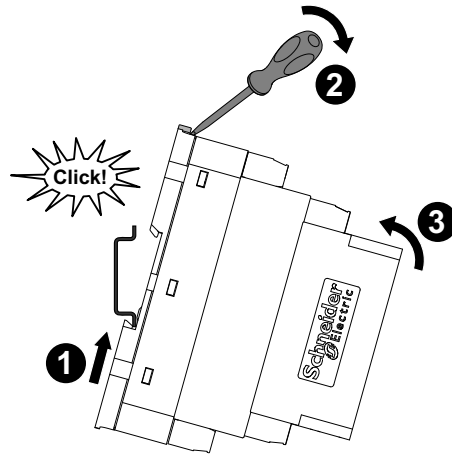

1. Locate the two DIN rail clips at the back of the LTMT main unit. Fit the bottom clip onto the DIN rail.
2. Push the LTMT main unit towards the DIN rail until the top clip catches.

NOTE: Make sure to leave enough space for the clearance zone.

Removing from DIN Rail

To remove the LTMT main unit from the DIN rail proceed as follows:

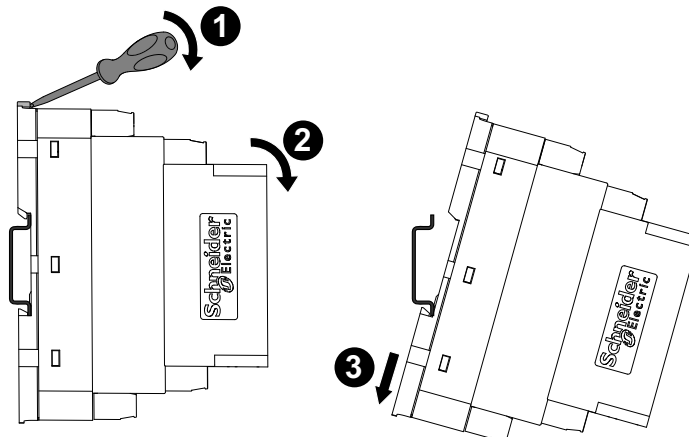

1. Using a flat screwdriver, pull up the locking mechanism to release the LTMT main unit.
2. Lift the LTMT main unit away from the DIN rail.
3. Pull out the DIN rail clip of the LTMT main unit away from the DIN rail.

Mounting on Solid Mounting Plate

Mount the LTMT main unit on a metal mounting plate using two M3.5 x 25 screws.

NOTE:

- The screws, washers, and nuts are not delivered as part of the package.
- The thickness of the mounting plate must not exceed 7 mm (0.275 in.).

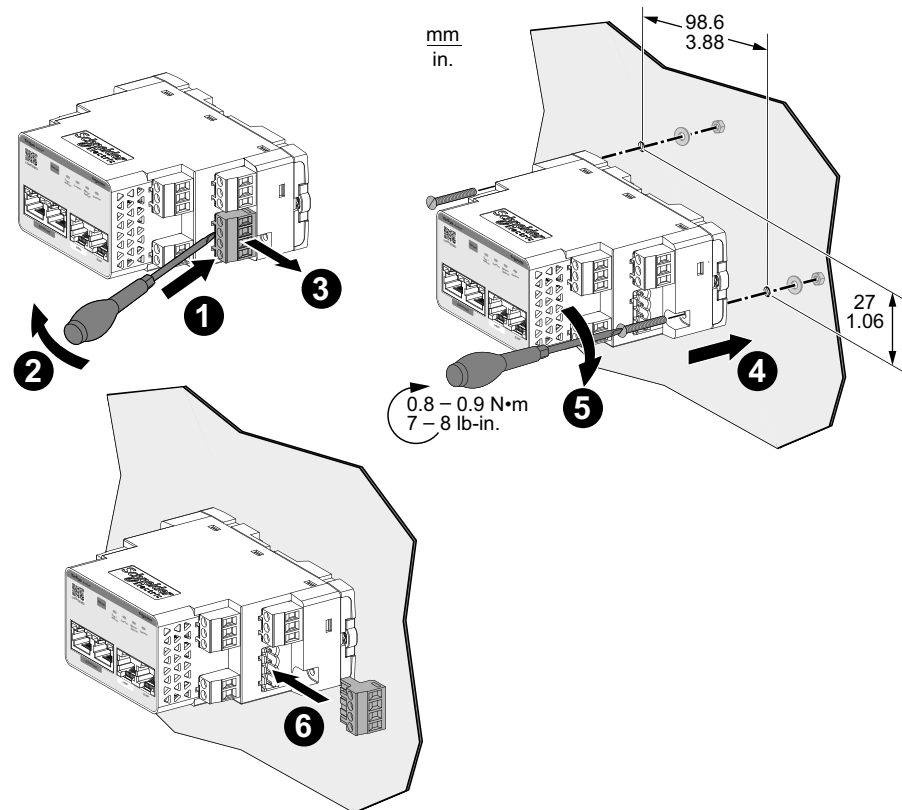

To mount the LTMT main unit on a mounting plate proceed as follows:

1. Insert a flat screwdriver under the bottom right 4-terminal connector.
2. Lift the screwdriver to release the connector from the LTMT main unit.
3. Remove the connector from the slot on the LTMT main unit to expose the mounting holes.
4. Position the LTMT main unit on the mounting plate.

NOTE: Make sure to leave enough space for the clearance zone.

5. Insert the two tapping screws in the mounting holes at each corner of the LTMT main unit. Tighten each screw to a torque of 0.8 to 0.9 N•m (7 to 8 lb-in).
6. Insert the connector back into the slot on the LTMT main unit.

Operating Position

Mount the LTMT main unit at an angle of up to 90° perpendicular to the normal vertical mounting plane.

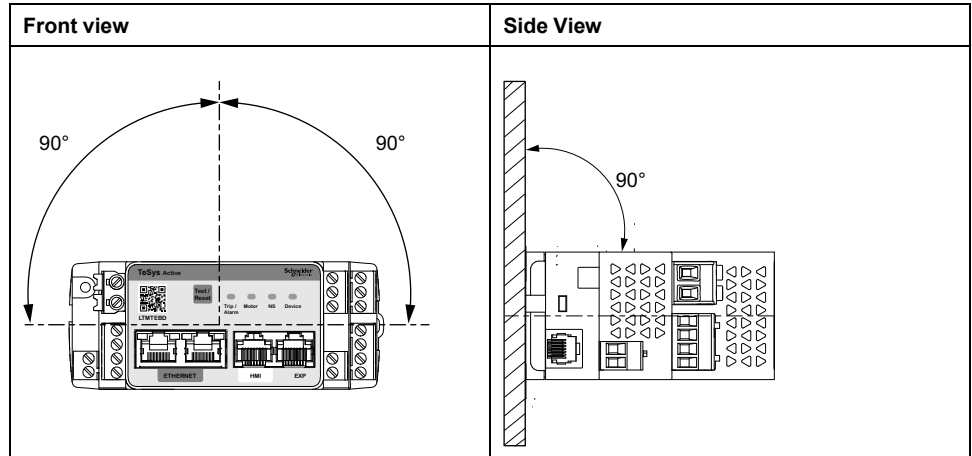

LTMTCT••T/LTMTCTV••T Horizontal Sensor Module Mounting

NOTE: The installation steps for LTMTCT••T/LTMTCTV••T horizontal sensor module (IEC application) and LTMTCTV••UT horizontal sensor module (side connector application) contactors are identical.

Mounting on DIN Rail

Mount the LTMTCT••T/LTMTCTV••T horizontal sensor module on a 35 mm (1.38 in.) DIN rail with a thickness of 1.35 mm (0.05 in.) and 0.75 mm (0.02 in.).

To mount the sensor module:

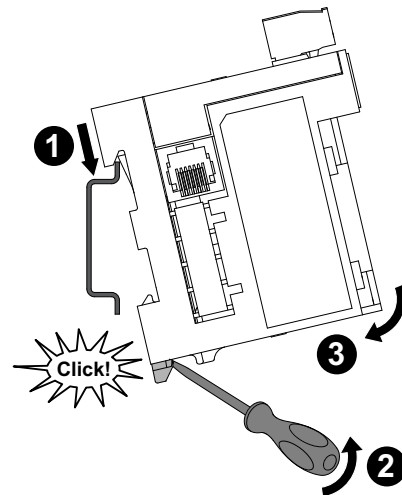

1. Locate the DIN rail clip at the back of the sensor module. Fit the top clip onto the DIN rail.
2. Push the sensor module towards the DIN rail until the bottom clip catches.

Removing from DIN Rail

To remove the LTMTCT••T/LTMTCTV••T horizontal sensor module from the DIN rail:

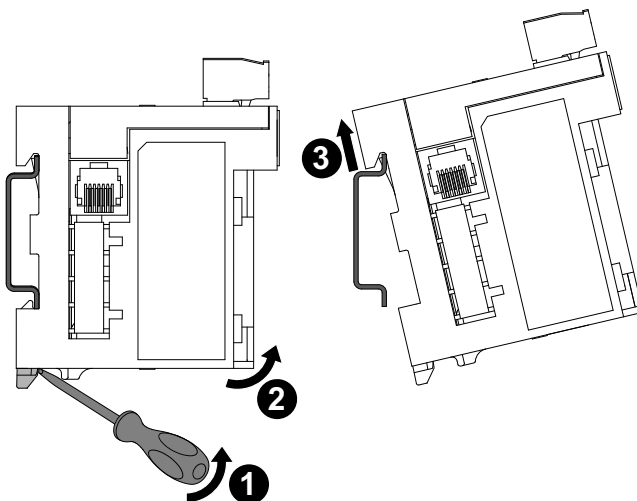

1. Using a flat screwdriver, pull up the locking mechanism to release the sensor module.
2. Lift the sensor module away from the DIN rail.
3. Pull out the DIN rail clip of the sensor module away from the DIN rail.

Mounting on Solid Mounting Plate

Mount the LTMTCT••T/LTMTCTV••T horizontal sensor module on a metal mounting plate using four M3.5 x 25 screws.

NOTE: The screws, washers, and nuts are not delivered as part of the package.

The thickness of the mounting plate must not exceed 7 mm (0.275 in).

To mount the sensor module on a mounting plate:

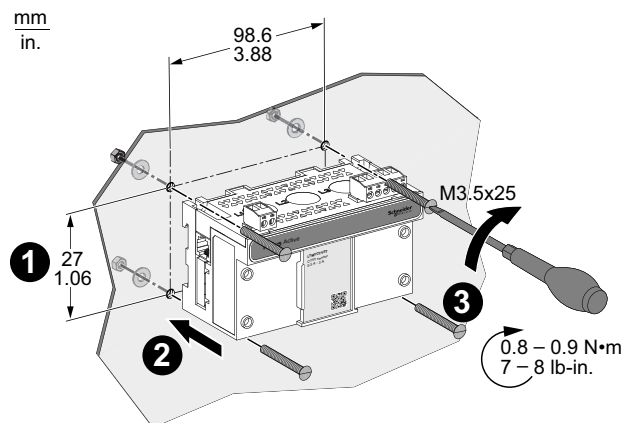

1. Locate the four mounting holes at each corner of the sensor module.
2. Position the sensor module on the mounting plate.
3. Insert the four tapping screws in the mounting holes at each corner of the sensor module. Tighten each screw to a torque of 0.8 to 0.9 N•m (7 to 8 lb-in).

NOTE: Make sure to leave enough space for the clearance zone.

Operating Position

Mount the LTMCTCT••T/LTMTCTV••T horizontal sensor module at an angle of up to 90° perpendicular to the normal vertical mounting plane.

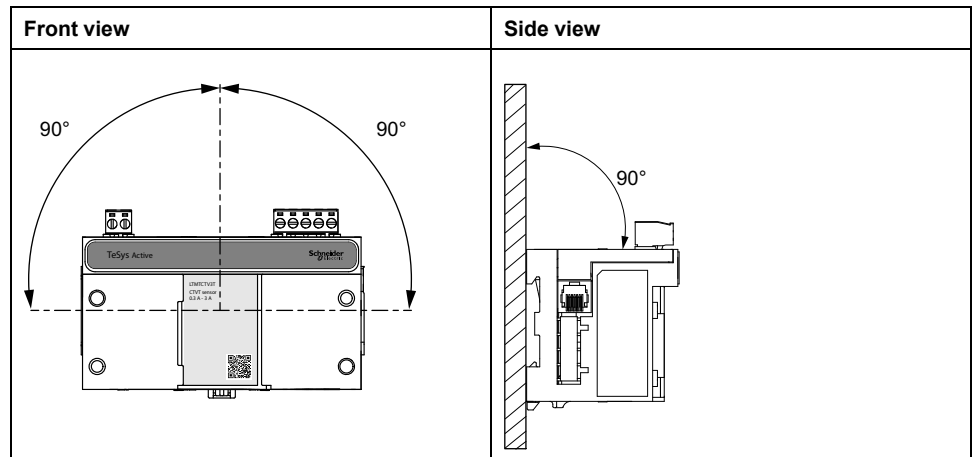

LTMT Expansion Module Mounting

Mounting on DIN Rail

You can mount the LTMT expansion module on a 35 mm (1.38 in.) DIN rail with a thickness of 1.35 mm (0.05 in.) and 0.75 mm (0.02 in.).

To mount the LTMT expansion module:

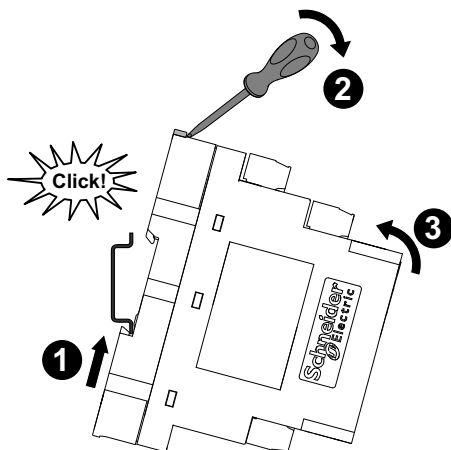

1. Locate the two DIN rail clips at the back of the LTMT expansion module. Fit the bottom clip onto the DIN rail.
2. Using a flat screwdriver, pull up the locking mechanism of the LTMT expansion module.
3. Push the LTMT expansion module towards the DIN rail until the top clip catches.
4. Remove the screwdriver to release the locking mechanism and to lock the LTMT expansion module on the DIN rail.

NOTE: Make sure to leave enough space for the clearance zone.

Removing from DIN Rail

To remove the LTMT expansion module from the DIN rail:

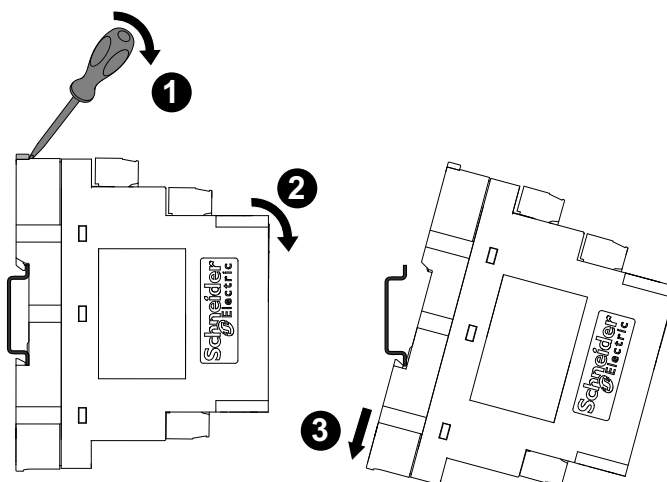

1. Using a flat screwdriver, pull up the locking mechanism to release the LTMT expansion module.
2. Lift the LTMT expansion module away from the DIN rail.
3. Pull out the DIN rail clip of the LTMT expansion module away from the DIN rail.

Mounting on Solid Mounting Plate

You can mount the LTMT expansion module on a metal mounting plate using two M3.5 x 25 screws.

NOTE:

- The screws, washers, and nuts are not delivered as part of the package.
- The thickness of the mounting plate must not exceed 7 mm (0.275 in).

To mount the LTMT expansion module on a mounting plate:

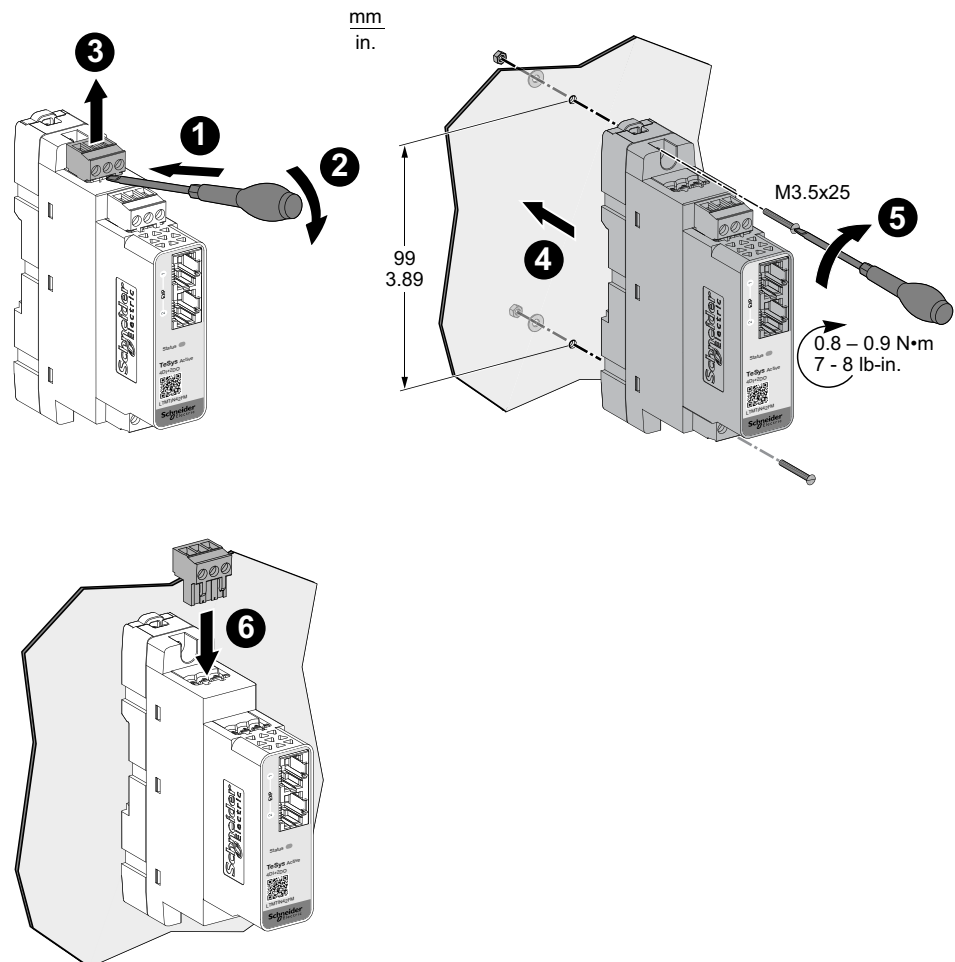

1. Insert a flat screwdriver under the top three terminal connector.
2. Pull down the screwdriver to release the connector from the LTMT expansion module.
3. Remove the connector from the slot on the LTMT expansion module to expose the mounting holes.
4. Position the LTMT expansion module on the mounting plate.

NOTE: Make sure to leave enough space for the clearance zone.

5. Insert the two tapping screws in the mounting holes on the top and bottom of the LTMT expansion module. Tighten each screw to a torque of 0.8 to 0.9 N•m (7 to 8 lb-in).
6. Insert the connector back into the slot on the LTMT expansion module.

Operating Position

You can mount the LTMT expansion module at an angle of up to 90° perpendicular to the normal vertical mounting plane.

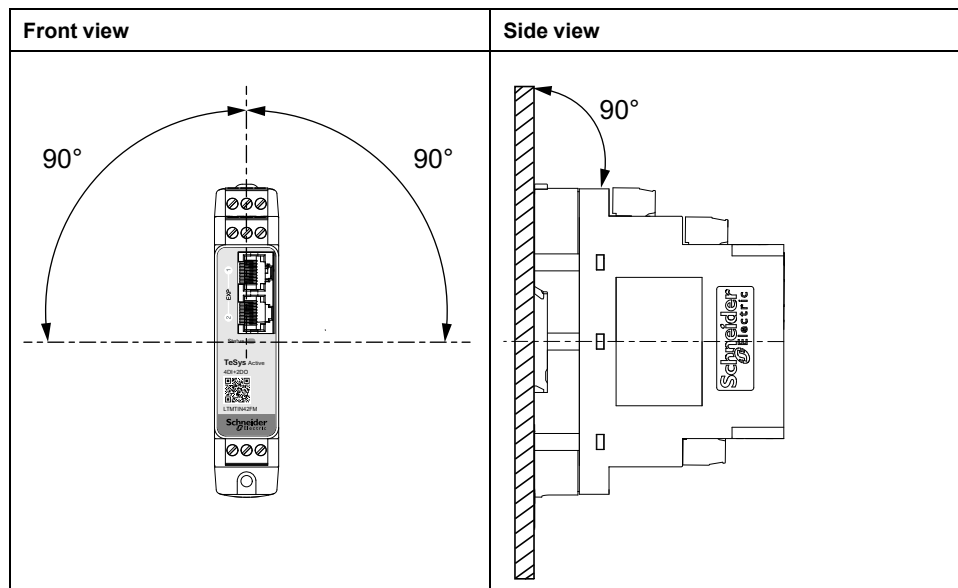

LTMTCUF Control Operator Unit Mounting

Inserting the Local Control Interface Label

The local control interface is the part of the LTMTCUF control operator unit that contains the five control keys and four LED. To identify these different elements, you can choose:

- One of the pre-defined labels
- The blank label that you can customize with a pen

The diagram below shows an example of a pre-defined label:

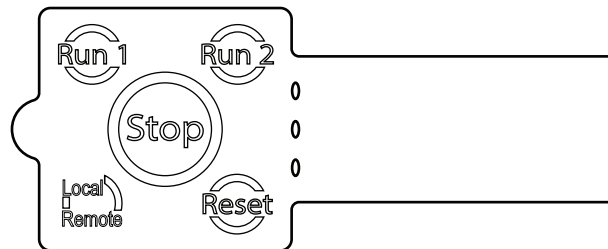

NOTE: Pre-defined labels and a blank label are delivered with the LTMTCUF control operator unit. The label must be chosen according to the LTMTCUF control operator unit operating mode. The control keys label on the local control interface must be appropriate to the functions of the LTMTCUF control operator unit operating mode.

Inserting Labels

To insert a local control interface label:

1. Slide the tip of the label into the slit on the side of the LTMTCUF control operator unit.

NOTE: Be careful to use the right slit as shown in the zoom view below.

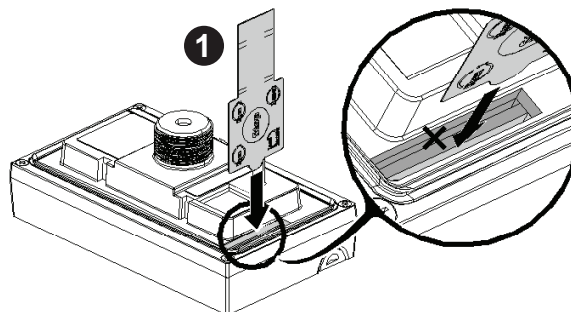

2. Slide the rest of the label into position in the LTMTCUF control operator unit, making sure that the identifiers on the label are correctly aligned with the interface elements.

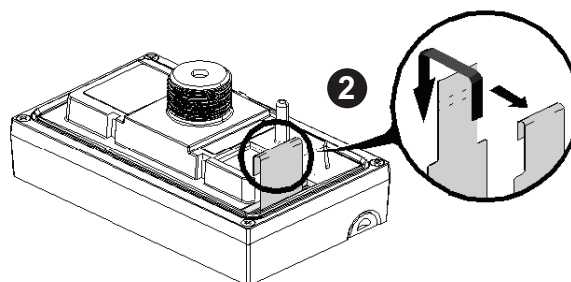

3. Insert the label tab into the tab loop.

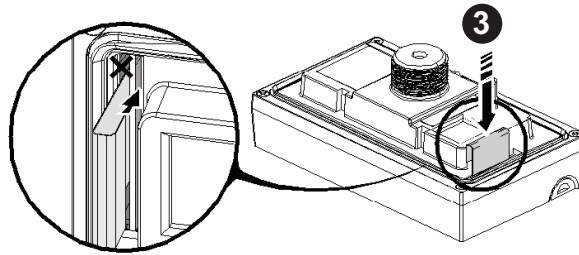

4. Push the tab into place so it lies flat against the loop.

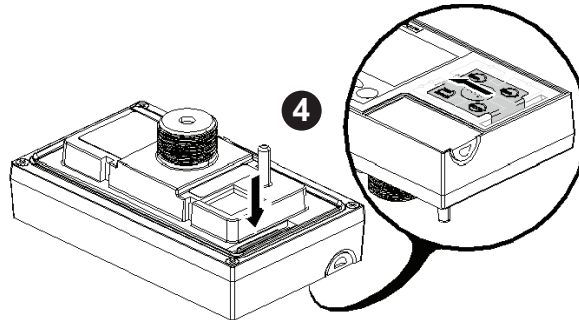

Flush Mounting the LTMTCUF Control Operator Unit

LTMTCUF Control Operator Unit Rear Face

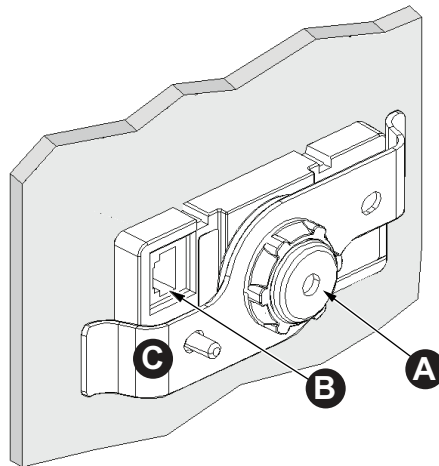

- A Mounting fixation (with mounting nut)
- B Rear RJ45 port
- C Clamp

Panel Setup

To setup the panel, follow the steps below:

1. Check that the panel surface is flat, in good condition, and has no jagged edges. Metal reinforcing strips can be attached to the inside of the panel, near the panel opening, to increase the panels rigidity.
2. The thickness of the panel should be from:
 - a. 3.5 to 6 mm (0.1 to 0.2 in) with additional washer.
 - b. 0.8 to 3.5 mm (0.03 to 0.1 in) without additional washer.

3. Make sure that the ambient operation temperature and the ambient humidity are within their designated ranges. When installing the LTMTCUF control operator unit in an enclosure, the ambient operation temperature is the enclosures internal temperature.
4. Make sure that heat from surrounding equipment does not cause the LTMTCUF control operator unit to exceed its standard operating temperature. For more information, refer to the Environmental Characteristics section in the *TeSys Tera Motor Management System LTMTCUF Control Operator Unit User Guide – DOCA0233***.

Operating Position

When installing the LTMTCUF control operator unit in a slanted panel, the panel face should not incline more than 30° and the range of ambient temperature is –20 to +50 °C(-4 to +131 °F).

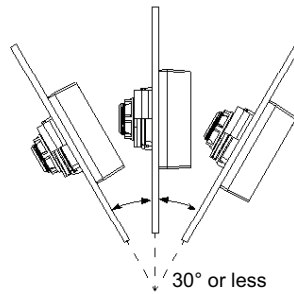

Flush Mounting Procedure Inside Panel Cutout

The flush mounting procedure is as follows:

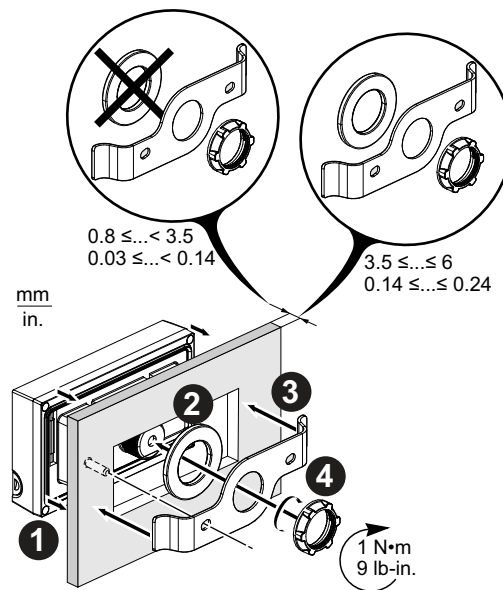

1. Insert the LTMTCUF control operator unit into the front door panel cut.
2. Position the metallic washer to the unit only if the panel thickness is more than 3.5 mm (0.14 in).

NOTE: A metallic washer is not required if the panel thickness is less than 3.5 mm (0.14 in).

3. Position the clamp onto the unit.
4. Insert the locking nut and tighten it to a torque of 1 N·m (9 lb-in).

Assembly

What's in This Chapter

Assembling LTMT Main Unit on LTMTCT/LTMTCTV Horizontal Sensor Module	48
---	----

Assembling LTMT Main Unit on LTMTCT/LTMTCTV Horizontal Sensor Module

Follow the procedures listed below to assemble the LTMT main unit on LTMTCT••T/LTMTCTV••T horizontal sensor module:

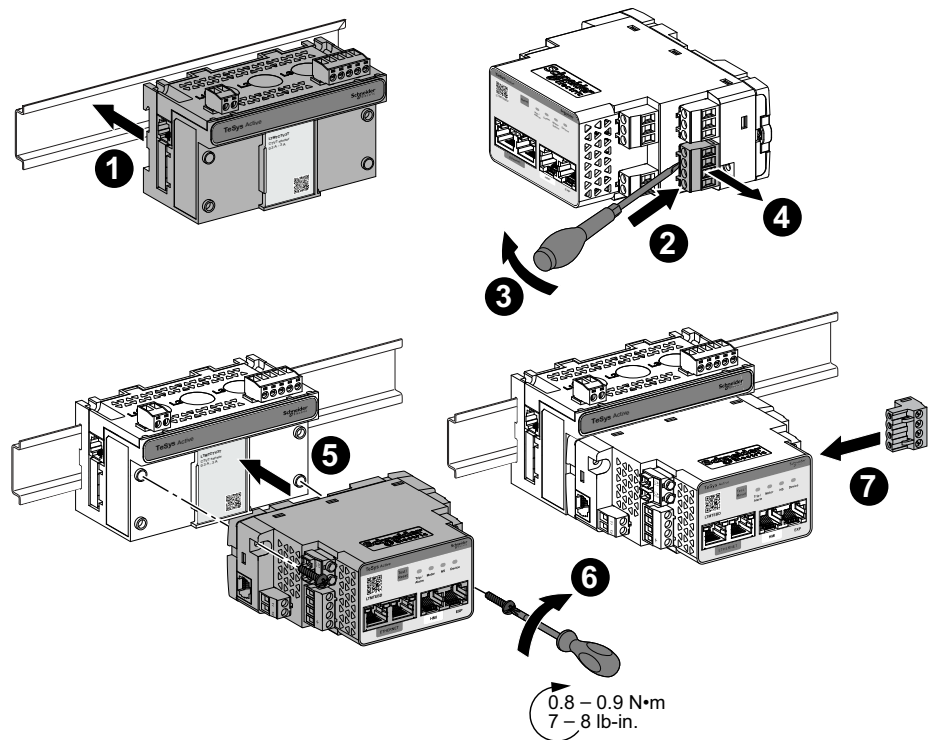

1. Mount the LTMTCT••T/LTMTCTV••T horizontal sensor module on the DIN rail, refer to *Mounting on DIN Rail*, page 34.
 2. Insert a flat screwdriver under the bottom right four-terminal connector of the LTMT main unit.
 3. Pull down the screwdriver to release the connector from the LTMT main unit.
 4. Remove the connector from the slot on the LTMT main unit.
 5. Assemble the connector on the LTMT Sensor Module.
 6. Insert the two tapping screws in the mounting holes at each corner of the main unit. Tighten each screw to a torque of 0.8 to 0.9 N•m (7 to 8 lb-in).
- NOTE:** The mounting screws are provided with the LTMT Sensor Module.
7. Insert the connector back into the slot on the LTMT main unit.

Component Interconnection

What's in This Chapter

Connection Cables	50
Connection of LTMT Main Unit to LTMTCT/LTMTCTV Horizontal Sensor Module	51
Connection of LTMT Main Unit to LTMT Expansion Module	53
Connection of the LTMT Main Unit to PC	54
Connection of LTMT Main Unit to LTMTCUF Control Operator Unit	55

Connection Cables

NOTICE

DEVICE DAMAGE

Use Schneider Electric standard cables.

Failure to follow these instructions can result in equipment damage.

The following table lists the connection cables of TeSys Tera system:

Reference number	Cable description	Cable type	Cable length
LTMT9RJ1015	LTMT main unit to LTMTCT/LTMTCTV sensor module	RJ11	0.2 m (7.8 in.)
LTMT9RJ105	LTMT main unit to LTMTCT/LTMTCTV sensor module	RJ11	0.5 m (19.6 in.)
LTMT9RJ401	LTMT main unit to LTMT expansion module	RJ45	0.1 m (3.9 in.)
LTMT9RJ102	LTMT main unit to LTMTCT/LTMTCTV sensor module	RJ45	0.2 m (7.874 in.)
LTMT9EX10	LTMT main unit to LTMT expansion module	RJ45	1 m (39.37 in.)
LTMT9CU10S	LTMT main unit to LTMTCUF control operator unit	RJ45	1 m (39.37 in.)
LTMT9CU30S	LTMT main unit to LTMTCUF control operator unit HMI	RJ45	3 m (118.11 in.)
TCSMCNAM3M002P	PC to LTMT main unit	USB to RJ45	2.5 m (98.42 in.)
TSXPBSCA100	PROFIBUS DP connecting cable for PROFIBUS DP connector	Shielded twisted pair	100 m (3937 in.)
TSXPBSCA400	PROFIBUS DP connecting cable for PROFIBUS DP connector	Shielded twisted pair	400 m (15748 in.)
490NTW00002	EtherNet/IP or Modbus TCP/IP network	Shielded category five straight-through twisted-pair cable with two RJ45 connectors.	2 m (78.7402 in.)

Connection of LTMT Main Unit to LTMTCT/LTMTCTV Horizontal Sensor Module

Use the LTMT9RJ1015 RJ11 cable to connect the LTMT main unit to the LTMTCT••T/LTMTCTV••T horizontal sensor module when assembled together.

1. Plug the LTMT9RJ1015 RJ11 cable in the RJ11 ports on the LTMT main unit and the LTMTCT••T/LTMTCTV••T horizontal sensor module.
2. Loop the cable and use the tie wrap to tie the RJ11 cable.

NOTE: Make sure that the RJ11 cable is away from the conductors.

3. Use a plier to cut and discard the remaining length of the unused tie wrap.

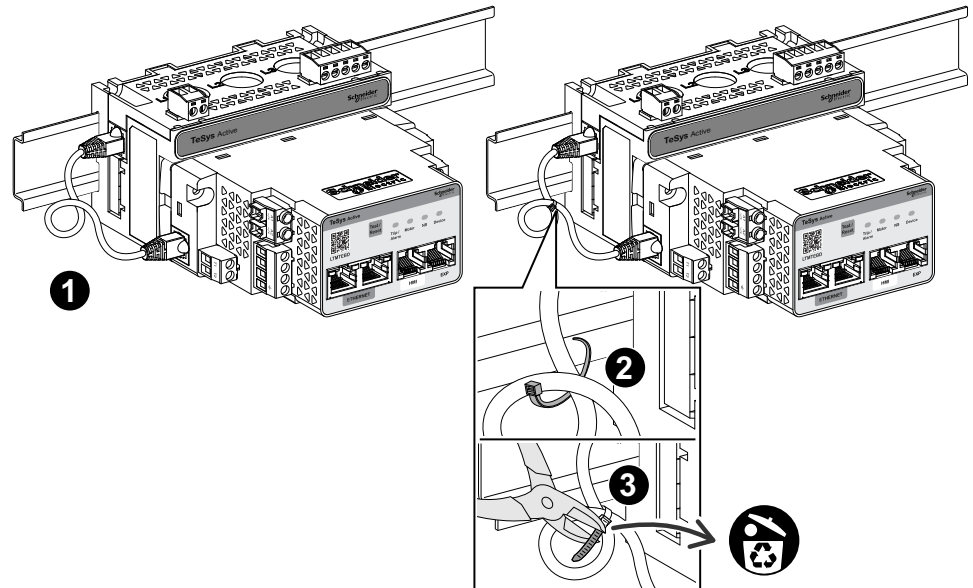

Connection of LTMT Main Unit to LTMTCT/LTMTCTV Horizontal Sensor Module Mounted Side by Side

Use the LTMT9RJ1015 or LTMT9RJ105 or LTMT9RJ102 RJ11 cable to connect the LTMT main unit to the LTMTCT••T/LTMTCTV••T horizontal sensor module when they are mounted side by side.

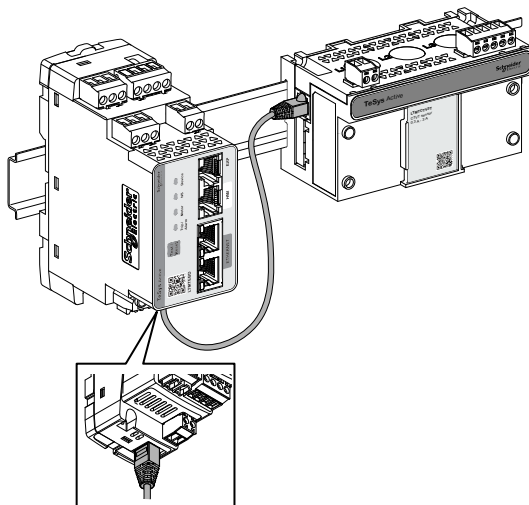

Connection of LTMT Main Unit to LTMT Expansion Module

The maximum number of LTMT expansion module that can be connected to one LTMT main unit is five modules.

Different types of the LTMT expansion module can be connected to one LTMT main unit. The maximum number of each LTMT expansion module that can be connected to one LTMT main unit is given in the following table:

LTMT expansion module	Maximum number of expansion modules	Reference
4 digital inputs and 2 digital outputs	Five	<ul style="list-style-type: none"> • LTMTIN42BD • LTMTIN42FM
2 analog inputs and 1 analog output	Two	LTMTAN21

The connection between LTMT main unit and other LTMT expansion module is in daisy chain configuration. The LTMT expansion module has two RJ45 port. Both the ports can work as either input port or output port.

To connect the LTMT main unit to the LTMT expansion module:

1. Using the LTMT9RJ401 or LTMT9EX10 cable, connect the cable from **EXP** port of the LTMT main unit to one of the RJ45 port of the first LTMT expansion module.
2. Connect the other RJ45 of the first LTMT expansion module to one of the RJ45 port of second LTMT expansion module.
3. Repeat step 2 for the remaining LTMT expansion modules.

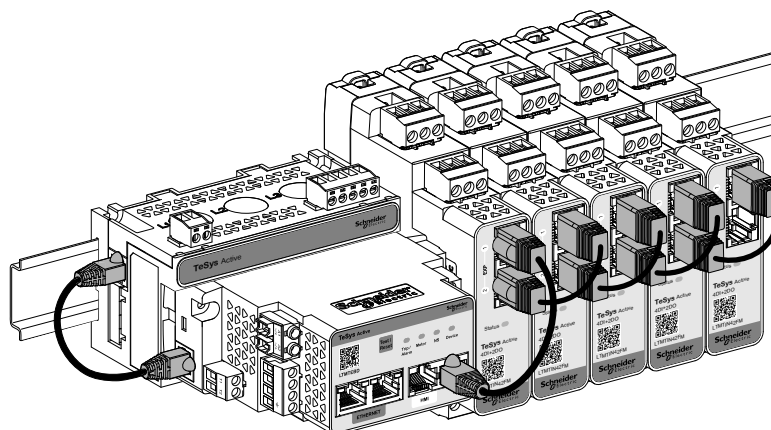

Connection of the LTMT Main Unit to PC

Use USB/RJ45 cable to connect USB port of the PC running the TeSys Tera DTM to the RJ45 port marked HMI on the LTMT main unit.

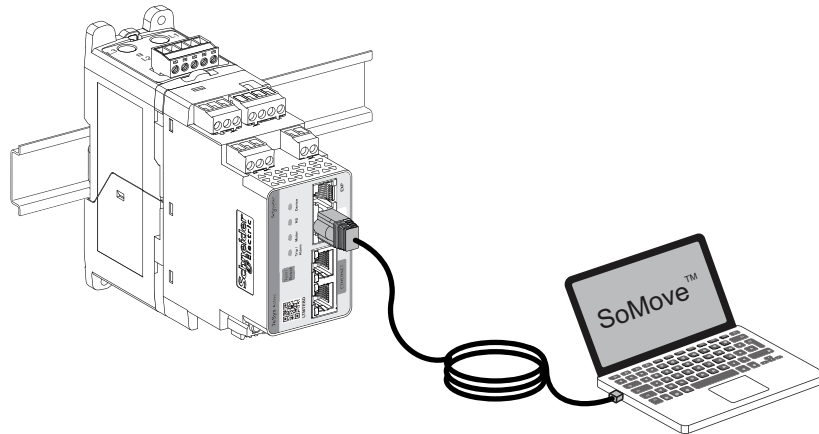

Connection of LTMT Main Unit to LTMTCUF Control Operator Unit

To provide connections for both the communication signals and the power supply follow the steps below:

1. Mount the LTMTCUF control operator unit.
2. Connect it to LTMT main unit through the RJ45 port at the rear of the unit to the RJ45 port marked **HMI** on the LTMT main unit.

It is possible to connect a PC to the LTMTCUF control operator unit through the RJ45 port on the front face of the unit.

The following section describes how to connect the LTMTCUF control operator unit to both the LTMT main unit and a PC.

Connecting to the LTMT Main Unit

Use the cable LTMT9CU10S or LTMT9CU30 to connect the LTMTCUF control operator unit to the RJ45 port marked **HMI** on the LTMT main unit front face.

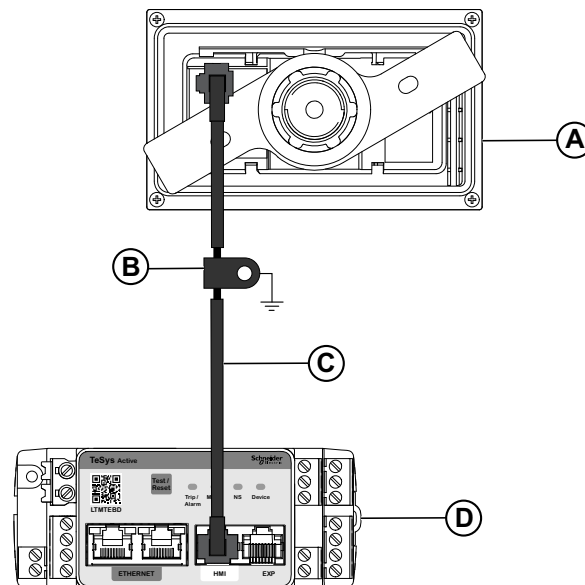

- A Backside of LTMTCUF control operator unit
- B Grounding collar
- C LTMT9CU10S or LTMT9CU30S HMI device connection cable
- D LTMT main unit

Connecting to a PC

Connect a PC to the LTMTCUF control operator unit through the RJ45 port on the front face of the unit.

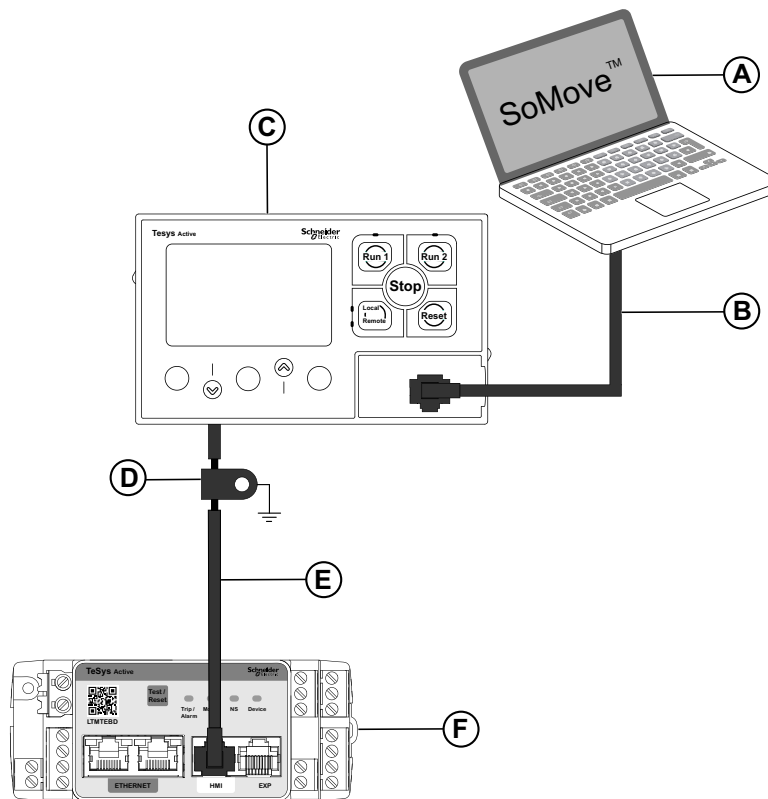

- A PC running the TeSys Tera DTM embedded in a FDT container, such as SoMove software
- B TCSMCNAM3M002P USB to RJ45 cable
- C LTMTCUF control operator unit
- D Grounding collar
- E LTMT9CU10S or LTMT9CU30S HMI device connection cable
- F LTMT main unit

NOTE:

When the LTMTCUF control operator unit is connected to a PC, the LTMTCUF control operator unit becomes passive and cannot be used to display information.

Wiring of the TeSys Tera Motor Management System

What's in This Part

- Wiring Guidelines 58
- Screw Terminal Connectors 59
- LTMT Main Unit Wiring 60
- LTMTCT/LTMTCTV Sensor Module Wiring..... 75
- LTMT Expansion Module Wiring 84
- Additional Wiring Instructions 89

Wiring Guidelines

The following wiring guidelines must be respected to reduce disturbance due to EMC on the behavior of the LTMT main unit:

- Keep sufficient distance as possible between the communication cable and the power and/or control cables (minimum 20 cm or 7.8 in.).
- Cross over different types of cables at right angles, if necessary.
- Do not bend or damage the cables. The maximum bending radius is 10 times the cable diameter.
- Avoid sharp angles of paths or passage of the cable.
- Use shielded cables to connect ground trip current transformers:
 - The cable shield must be connected to a protective ground at both ends.
 - The connection of the cable shield to the protective ground must be as short as possible.
 - Connect together all the shields, if necessary.
 - Perform the grounding of the shield with a collar.
- Systematically add resistive capacitive (RC) filters on contactor coils.

For more information, refer to chapter ElectroMagnetic Compatibility (EMC) in *Electrical Installation guide* (available in English only) and *Okken and BlokSeT guide*.

Screw Terminal Connectors

Screw Terminal Wiring Characteristics

The following table describes the characteristics of cables that may be used to wire screw terminals:

Cable type	Number of conductors	Conductor section	
		mm ²	AWG
Flexible (stranded) cable	Single conductor	0.25–2.5	24–12
	Two conductors	0.2–1.0	24–16
Solid cable	Single conductor	0.2–2.5	24–12
	Two conductors	0.2–1.0	24–18

⚠ CAUTION

EQUIPMENT DAMAGE

Do not use a wire gauge that is higher than the recommended gauge.

Failure to follow these instructions can result in injury or equipment damage.

The following table describes the characteristics of screw terminals:

Pitch	5 mm	0.2 in.
Tightening torque	0.2 N•m	3 lb-in
Flat screwdriver	3 mm	0.10 in.

Screw terminals have an insulation rating of 320 Vac.

LTMT Main Unit Wiring

Connector Location

The location of the connectors on the LTMT main unit is shown in the figure below:

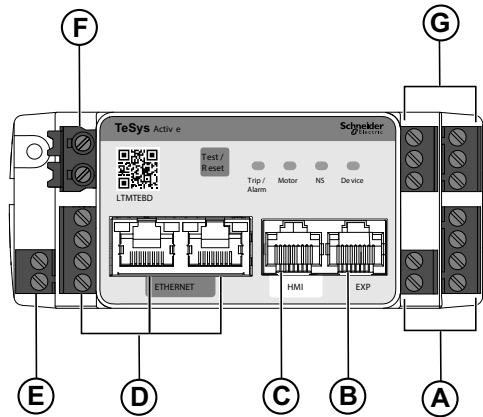

- A Digital input connectors
- B RJ45 port for LTMT expansion module connection
- C RJ45 port for HMI connection
- D Communication ports
- E Temperature input connector
- F Power supply connector
- G Digital output connectors

The LTMT main unit has the following plug-in connectors.

Connector	Terminal	Description
A (Digital input)	I.1	Digital input 1
	I.2	Digital input 2
	I.3	Digital input 3
	I.4	Digital input 4
	+24V	Common for digital inputs when internally powered
E (Temperature input)	T1	Temperature input (PT100 or PTC)
	T2	
F (Power supply)	A1~/+	Power supply
	A2~/–	
G (Digital output)	O3.NO	Digital output 3 - Normally Open
	O3.C2	Digital output 3 - Common for digital output 3
	O3.NC	Digital output 3 - Normally closed contact
	O1/13	Digital output 1 - Normally open contact
	C1/14	Common for digital outputs 1 and 2
	O2/23	Digital output 2 - Normally open contact

For terminal wiring characteristics, refer to Screw Terminal Wiring Characteristics, page 59.

Wiring Diagram

The wiring diagram shows a typical example of a LTMT main unit with a LTMTCTV sensor modules used as overload, direct online, reverse direct online, star delta, and single-phase motor application.

Overload

Example of wiring diagram of the TeSys Tera system in Overload starter:

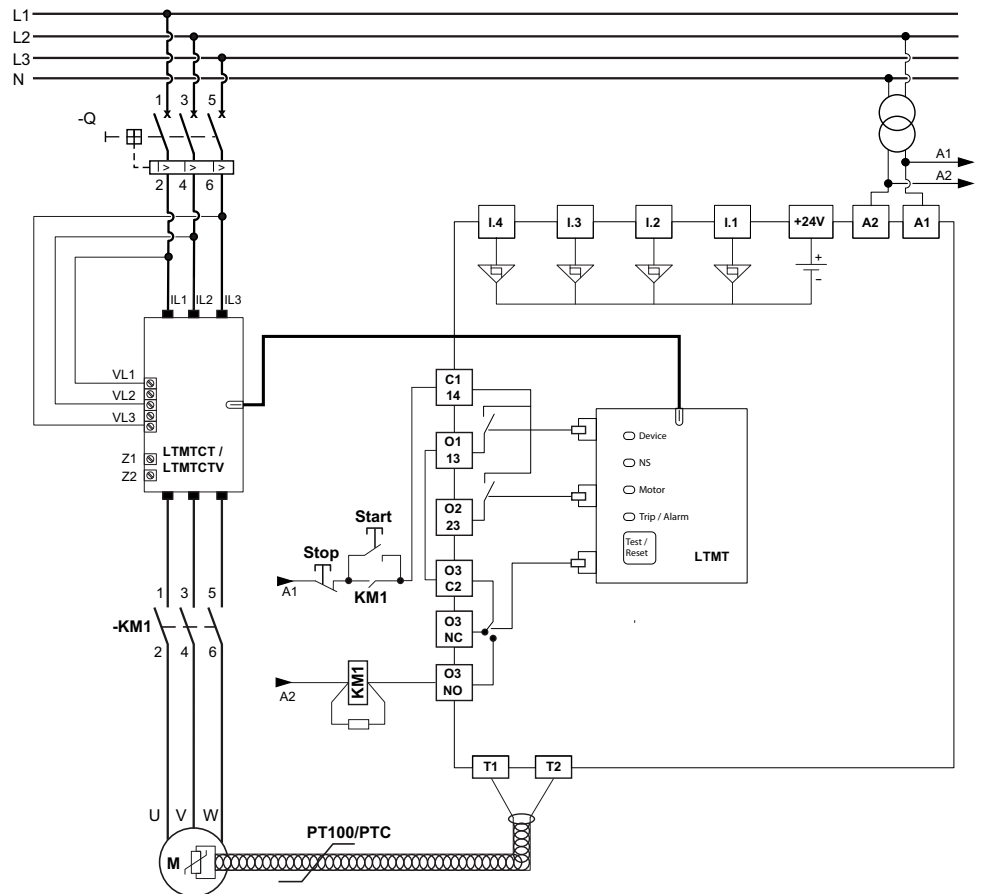

NOTE: Terminal O1 and O3 are connected in series.

For AC Voltage:

- A1 is 110/240 Vac (L) or Vdc (+Ve)
- A2 is 110/240 Vac (N) or Vdc (-Ve)

For DC Voltage:

- A1 is +24 Vdc
- A2 is negative

For DI and DO terminal block:

- 4DI
- 3DO

For temperature input:

- T1
- T2

Direct Online

Example of wiring diagram of the TeSys Tera system in Direct Online mode:

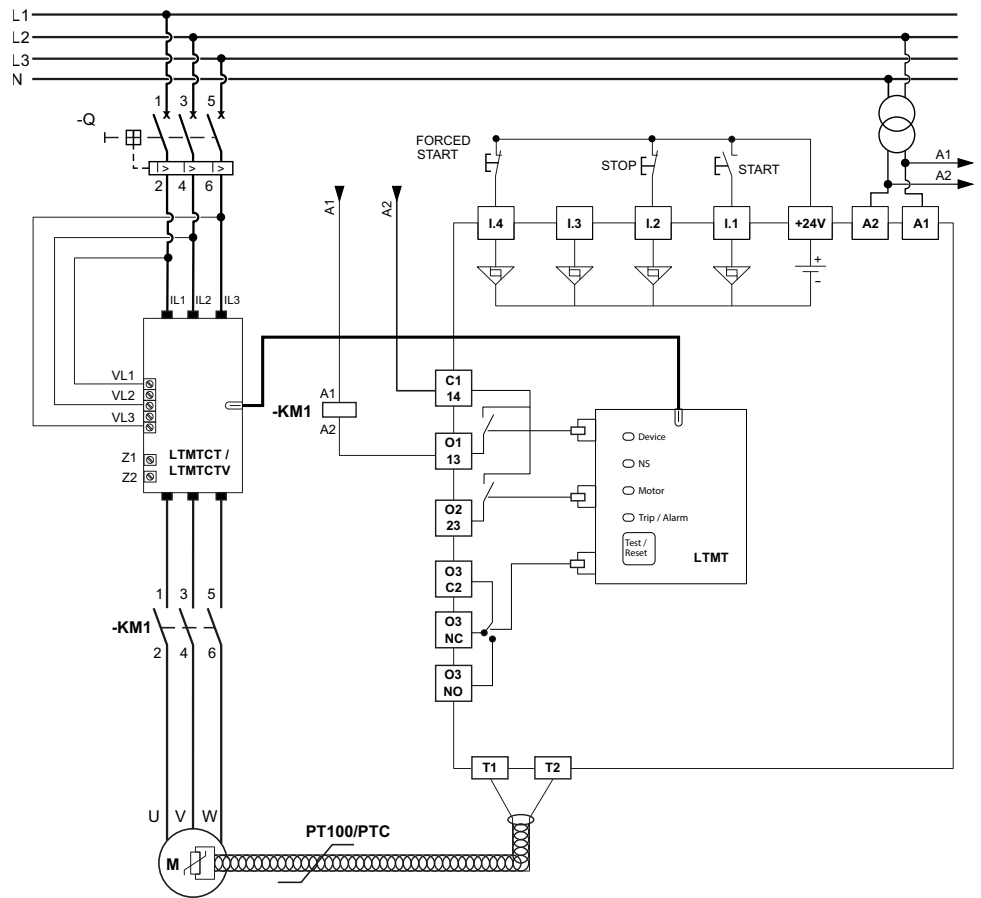

Star Delta

Example of wiring diagram of the TeSys Tera system in Star Delta mode:

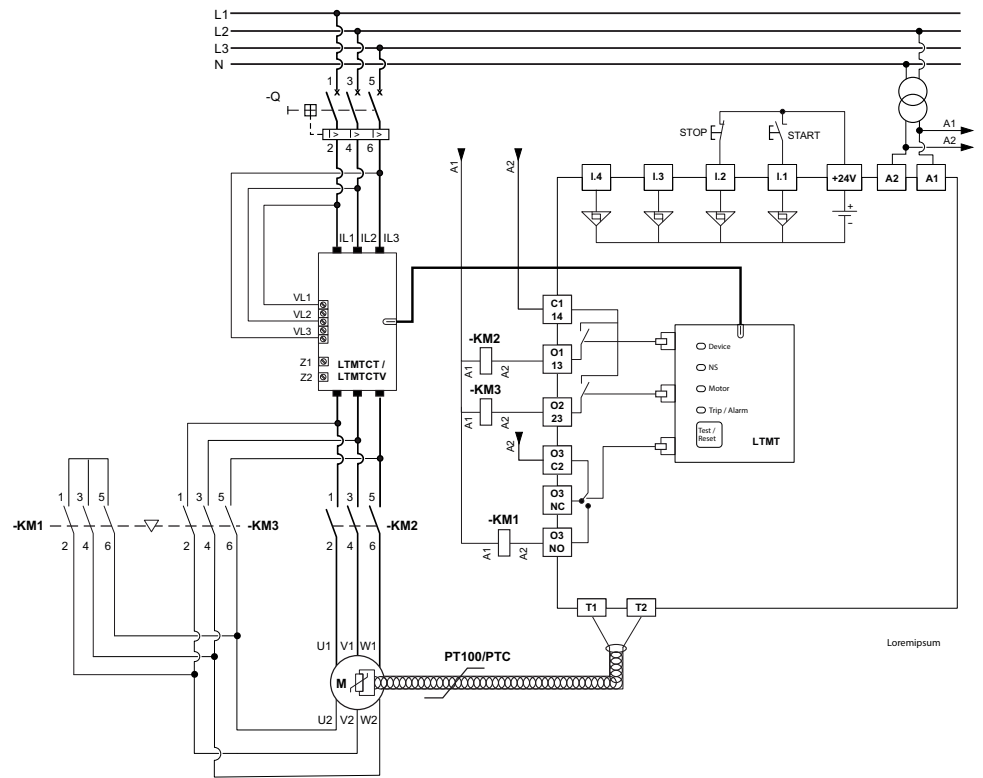

KM1: CONTACTOR OUTPUT 1 (Star)

KM2: CONTACTOR OUTPUT 2 (Main or Line)

KM3: CONTACTOR OUTPUT 3 (Delta)

NOTE: Mechanical interlock is connected to KM1 and KM3.

Single Phase Motor Application

Example of wiring diagram of the Direct Online mode with single-phase motor:

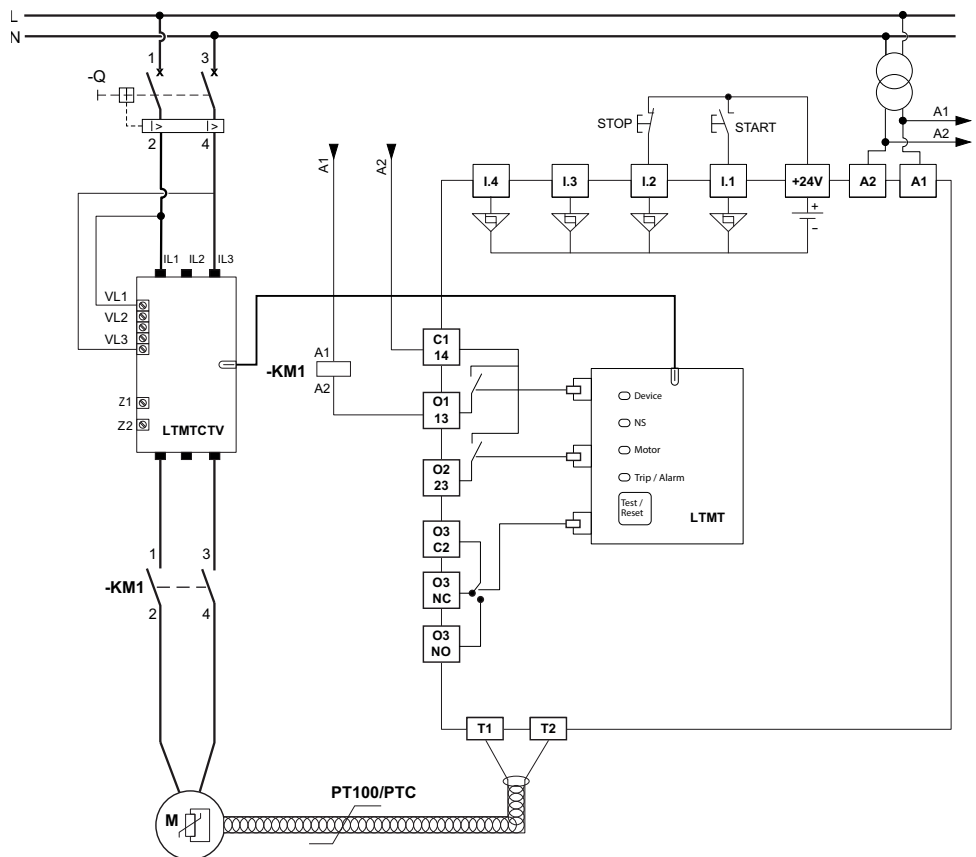

LTMT Digital Inputs Wiring

The LTMT main unit has four potential free digital inputs (type 1 according to EN61131-2 standard).

The digital inputs can be powered through internally by the LTMT main unit.

Digital inputs are powered internally, the four digital inputs I.1, I.2, I.3 and I.4 can be used.

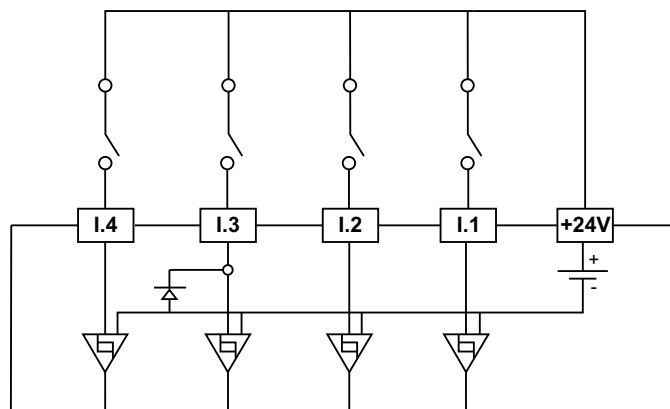

LTMT Temperature Inputs Wiring

A 2-wire PT100 or PTC temperature sensor can be connected to the LTMT main unit.

Use unshielded twisted pair cable (14 AWGx2 of maximum length 300 m) to connect the main unit to the temperature sensor.

LTMT HMI Port Wiring

The RJ45 HMI port can be used in two ways:

- Connection port for the PC running the TeSys Tera DTM during commissioning, refer to [Connection of the LTMT Main Unit to PC](#), page 54.
- The LTMTCUF control operator unit connection port, refer to [Connection of LTMT Main Unit to LTMTCUF Control Operator Unit](#), page 55.

LTMT EtherNet/IP Port Wiring

NOTICE
<p>UNAUTHORIZED ETHERNET PORT USAGE</p> <p>Use only one Ethernet communication port at a time, even though both ports are functionally identical.</p> <p>Failure to follow these instructions can result in equipment damage.</p>

The LTMT main unit with EtherNet/IP or Modbus TCP/IP communication protocols is equipped with two RJ45 Ethernet communication ports on the front face. They follow the Ethernet interoperability standards. It allows star and point-to-point connections. The main physical characteristics of EtherNet/IP ports are:

Physical interface	Ethernet 10/100BASE-T
Connector	RJ45

Description

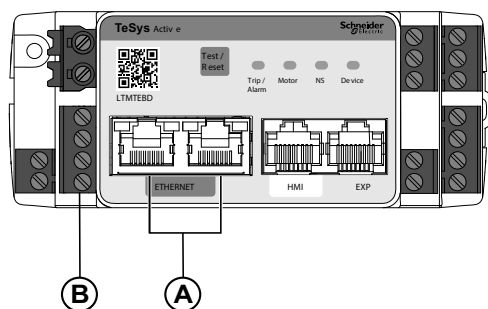

- A RJ45 ports for EtherNet/IP or Modbus TCP/IP communication
- B Device shield ground terminals

RJ45 Connector Pinout

The LTMT main unit is connected to the EtherNet/IP network using either or both of the RJ45 Ethernet communication ports in compliance with the following wiring:

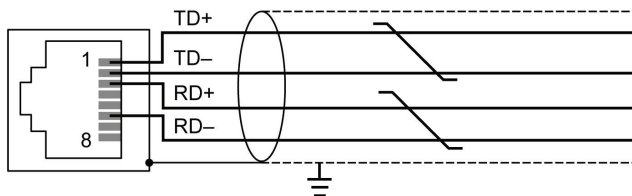

The RJ45 wiring layout is:

Pin No.	Signal	Pair	Description
1	TD+	A	Transmit +
2	TD-	A	Transmit -
3	RD+	B	Receive +
4	Do not connect	—	—
5	Do not connect	—	—
6	RD-	B	Receive -
7	Do not connect	—	—
8	Do not connect	—	—

EtherNet/IP Wiring Rules

The following wiring rules must be respected in order to reduce disturbance due to EMC on the behavior of the LTMT main unit:

- Keep minimum distance (20 cm or 7.8 in) between the communication and control cables.
- Do not bend or damage the cables. The maximum bending radius is 10 times the cable diameter.
- Install the communication cables as close as possible to the grounded plate.
- Avoid sharp angles of paths or passage of the cable.
- EtherNet/IP cable must be shielded:
 - Cable shield must be connected to a protective ground.
 - Connection of the cable shield to the protective ground must be as short as possible.
 - Connect the shields, if necessary.
- When the LTMT main unit is installed in a withdrawable drawer:
 - Connect all shield contacts of the withdrawable drawer part of the auxiliary connector to the ground of the withdrawable drawer, to create an electromagnetic barrier. Refer to the *Okken Communications Cabling & Wiring Guide*, *BlokseT Guide*, and *Model 6 Guide* (available on request).
 - Do not connect the cable shield at the fixed part of the auxiliary connector.

NOTE: Proper cable routing to be done to avoid pressure on connectors.

For more information on the EtherNet/IP network wiring, refer to the *TeSys Tera Motor Management System EtherNet/IP Communication Guide - DOCA0258*, page 9.

EtherNet/IP or Modbus TCP/IP Protocol Principle

The EtherNet/IP or Modbus TCP/IP protocol is a client or server protocol.

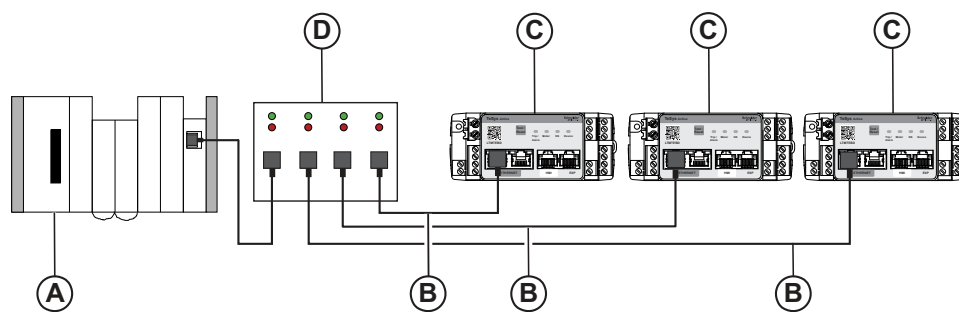

- A Client (PLC, PC, or communication module)
- B Shielded category five straight-through twisted-pair Ethernet cable with RJ45 connector
- C Server (LTMT main unit)
- D Ethernet switch

LTMT Modbus RTU Port Wiring

Modbus RTU Communication Port

The LTMT main unit with Modbus RTU communication is equipped with one Modbus RTU communication port on the front face.

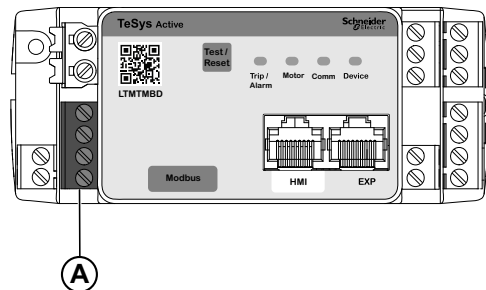

A Plug-in four terminal connector for connection to the Modbus RTU network with transmission rate up to 115.2 kbps

Modbus RTU Wiring Rules

The following wiring rules must be respected in order to reduce disturbance due to EMC on the behavior of the LTMT main unit:

- Keep minimum distance (20 cm or 7.8 in) between the communication and control cables.
- Do not bend or damage the cables. The maximum bending radius is 10 times the cable diameter.
- Install the communication cables as close as possible to the grounded plate.
- Avoid sharp angles of paths or passage of the cable.
- Modbus RTU cable must be a shielded twisted pair cable:
 - The twisted pair cable shield must be connected to a protective ground
 - The connection of the twisted pair cable shield to the protective ground must be as short as possible
 - Connect together all the shields, if necessary
 - Connect the shield to the \perp terminal
 - Perform the grounding with a metal clip.

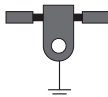

For more information on the Modbus RTU network wiring, refer to the *TeSys Tera Motor Management System Modbus RTU Communication Guide – DOCA0355••*, page 9.

LTMT Main Units Installed in an Enclosure

The wiring diagram for the connection of Modbus RTU installed in an enclosure to the RS 485 bus through open-style connectors is as follows:

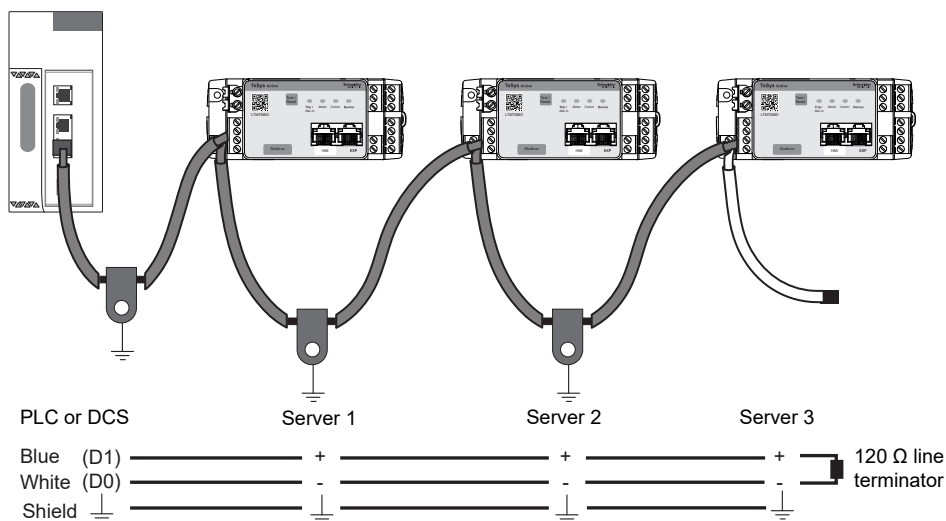

Wiring Diagram

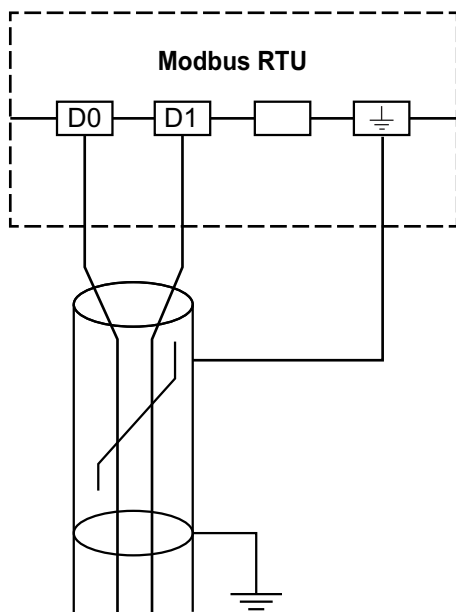

The terminal assignment is as follows for Modbus RTU protocol:

Terminal	Description
D0	Data -
D1	Data +
Blank	Not used
⏏	Shielded ground terminal (independent ground to the communication network)

Modbus RTU cable must be a shielded twisted pair cable.

For terminal wiring characteristics, refer to *Screw Terminal Wiring Characteristics*, page 59.

LTMT PROFIBUS DP Port Wiring

PROFIBUS DP Communication Ports

The LTMT main unit with PROFIBUS DP communication is equipped with two PROFIBUS DP communication ports on the front face.

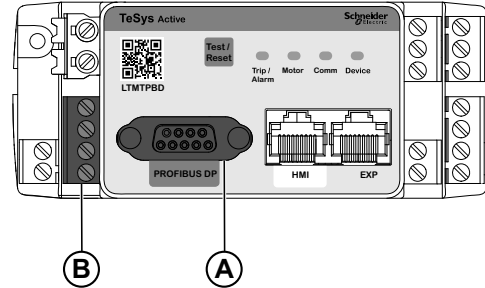

- A One sub-D 9 connector for connection to the PROFIBUS DP network with transmission rate up to 12 Mbits/s
- B Plug-in four terminal connector for connection to the PROFIBUS DP network with transmission rate up to 1.5 Mbits/s

Both ports are electrically identical. They follow the PROFIBUS DP interoperability standards. The use of the sub-D 9 connector is recommended.

IMPORTANT: The LTMT main unit must be connected through only one port.

PROFIBUS DP Wiring Rules

The following wiring rules must be respected in order to reduce disturbance due to EMC on the behavior of the LTMT main unit:

- Keep minimum distance (20 cm or 7.8 in) between the communication and control cables.
- Do not bend or damage the cables. The maximum bending radius is 10 times the cable diameter.
- Install the communication cables as close as possible to the grounded plate.
- Avoid sharp angles of paths or passage of the cable.
- PROFIBUS DP cable must be a shielded twisted pair cable:
 - The twisted pair cable shield must be connected to a protective ground.
 - The connection of the twisted pair cable shield to the protective ground must be as short as possible.
 - Connect together all the shields, if necessary.
 - Connect the shield to the \perp terminal.
 - Perform the grounding using a metal clip.

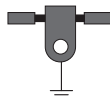

For more details on the PROFIBUS DP network wiring, refer to the *TeSys Tera Motor Management System PROFIBUS DP Communication Guide – DOCA0256***, page 9.

LTMT Main Units Connected with Terminal Connector

The wiring diagram for connection of PROFIBUS DP installed in an enclosure with the RS 485 bus through 4-terminal connectors is as follows:

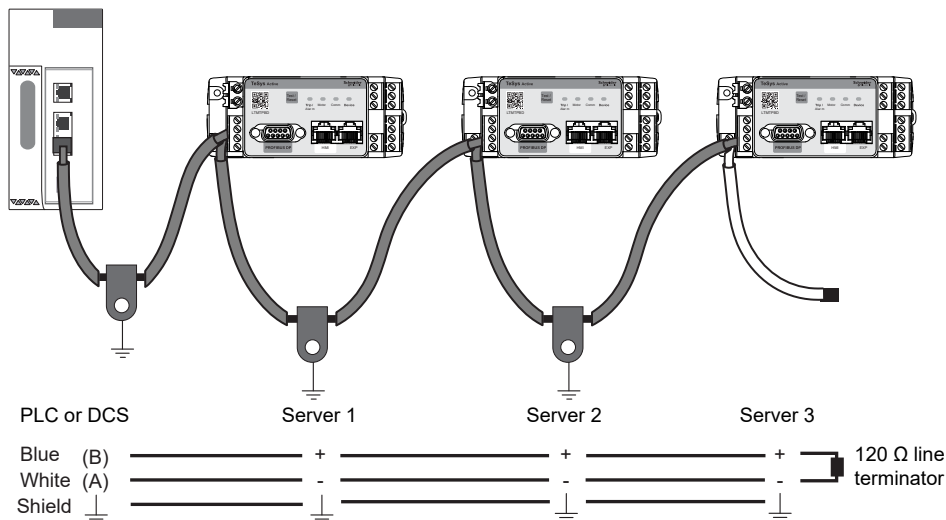

Wiring Diagram

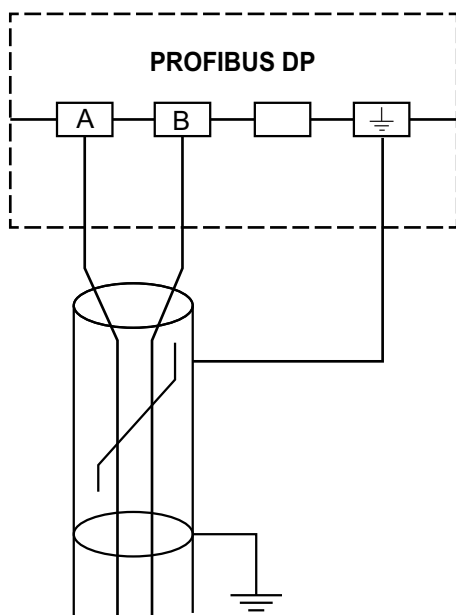

The terminal assignment is as follows for PROFIBUS DP protocol:

Terminal	Signal	Description
A	RD-/TD-	Negative data transmission (RD-/ TD-)
B	RD+/TD+	Positive data transmission (RD+/ TD+)
Blank	-	Not used
⊥	-	Shielded ground terminal (independent ground to the communication network)

PROFIBUS DP cable must be a shielded twisted pair cable.

For terminal wiring characteristics, refer to Screw Terminal Wiring Characteristics, page 59.

LTMT Main Units Connected with Sub-D 9 Connector

The wiring diagram for the connection of LTMT main units to the RS 485 bus through the sub-D 9 connector is as follows:

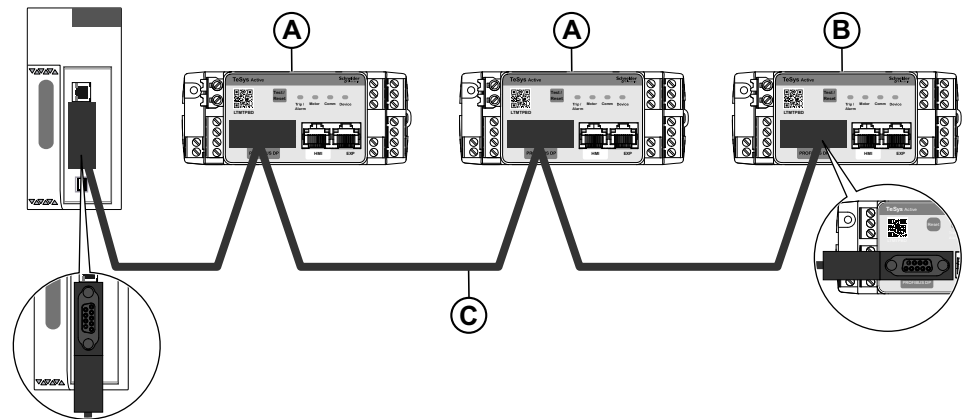

- A PROFIBUS DP sub-D 9 in-line connector or PROFIBUS DP sub-D 9 in-line connector with programming port
- B PROFIBUS DP sub-D 9 connector with terminator
- C TSXPBSCA•00 PROFIBUS DP shielded cable

PROFIBUS DP Sub-D 9 Connector Accessories

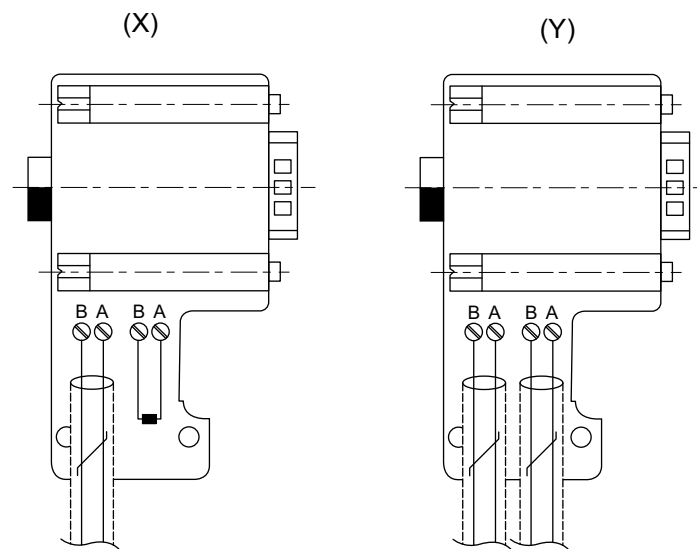

- X PROFIBUS DP sub-D 9 connector with terminator
- Y PROFIBUS DP sub-D 9 in-line connector or PROFIBUS DP sub-D 9 in-line connector with programming port

Sub-D 9 Connector Pin Assignment

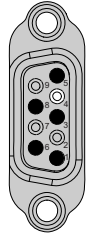

Pin number	Signal	Description
1	Shield	PROFIBUS DP cable shield
2	M24	Not used
3	RxD/TxD-P (B)	Positive data transmission (RD+ / TD+) = B
4	CNTR-P	Not used
5	DGND	Data transmission ground (Valid only for end device with line termination)
6	VP	Line termination bias voltage (Valid only for end device with line termination)
7	P24	Not used
8	RxD/TxD-N (A)	Negative data transmission (RD- / TD-) = A
9	CNTR-N	Not used

The TSXPBSCA•00 cable is used for connecting the PROFIBUS DP connector. For more details on PROFIBUS DP wiring, refer to the *TeSys Tera Motor Management System PROFIBUS DP Communication Guide – DOCA0256••*, page 9.

LTMTCT/LTMTCTV Sensor Module Wiring

LTMTCT••T/LTMTCTV••T Horizontal Sensor Module for IEC Application

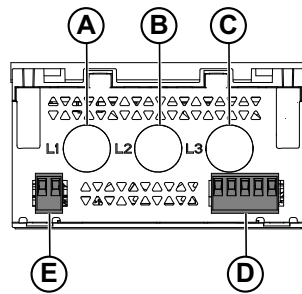

- A Window for phase 1 current measurement
- B Window for phase 2 current measurement
- C Window for phase 3 current measurement
- D Phase voltage input connector (on LTMTCTV modules only)
- E Ground current measurement input connector

LTMTCTV••UT Horizontal Sensor Module for Side Connector Application

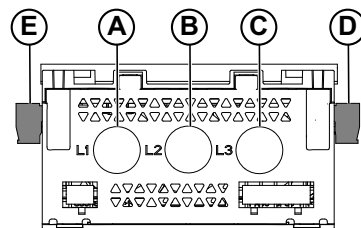

- A Window for phase 1 current measurement
- B Window for phase 2 current measurement
- C Window for phase 3 current measurement
- D Phase voltage input connector
- E Ground current measurement input connector

Examples of LTMTCT/LTMTCTV Wiring

LTMTCT Horizontal Sensor Modules for Three-Phase CT Without Voltage

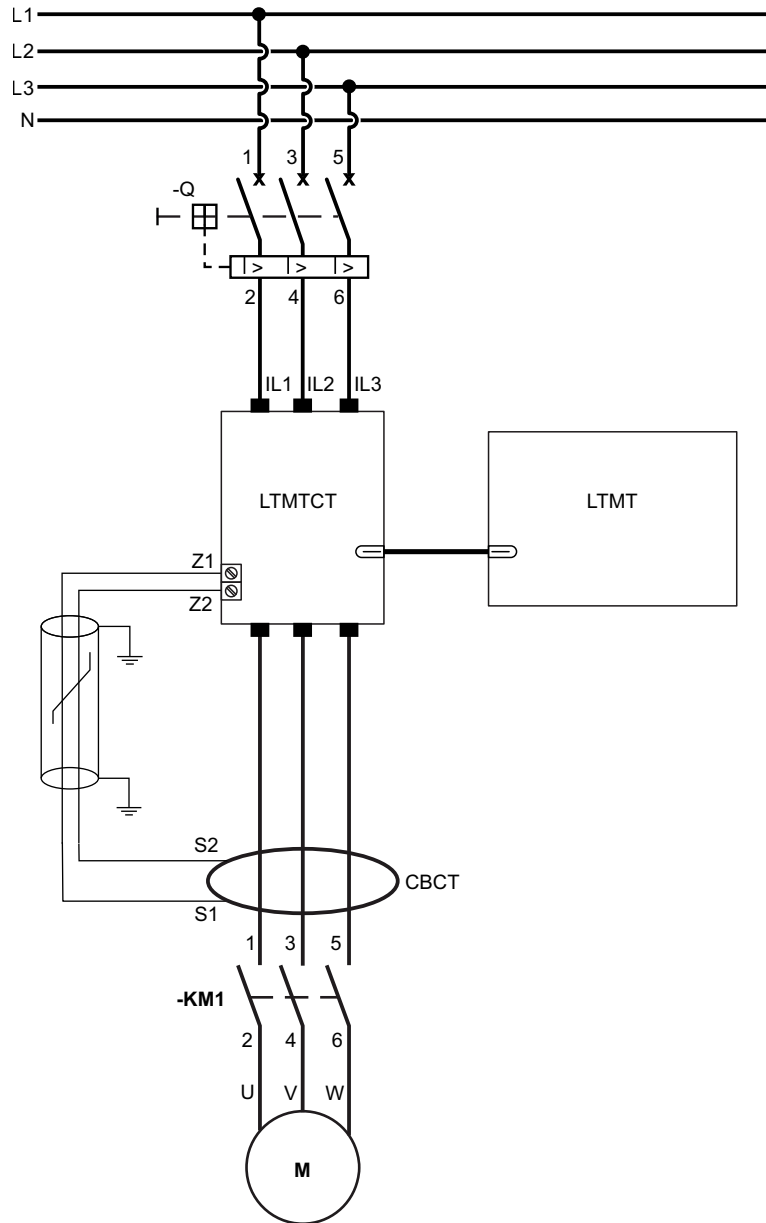

The following table represents the connection of LTMTCT••T/LTMTCTV••T horizontal sensor module and core balance current transformers (CBCT):

Connector	Terminal	Description
E (Ground current measurement input connector)	Z1	CBCT S1 terminal
	Z2	CBCT S2 terminal

Use shielded twisted pair cable to connect the LTMTCT••T/LTMTCTV••T horizontal sensor module to the external CBCT terminals.

For terminal wiring characteristics, refer to Screw Terminal Wiring Characteristics, page 59.

LTMTCT Horizontal Sensor Modules for Single-Phase

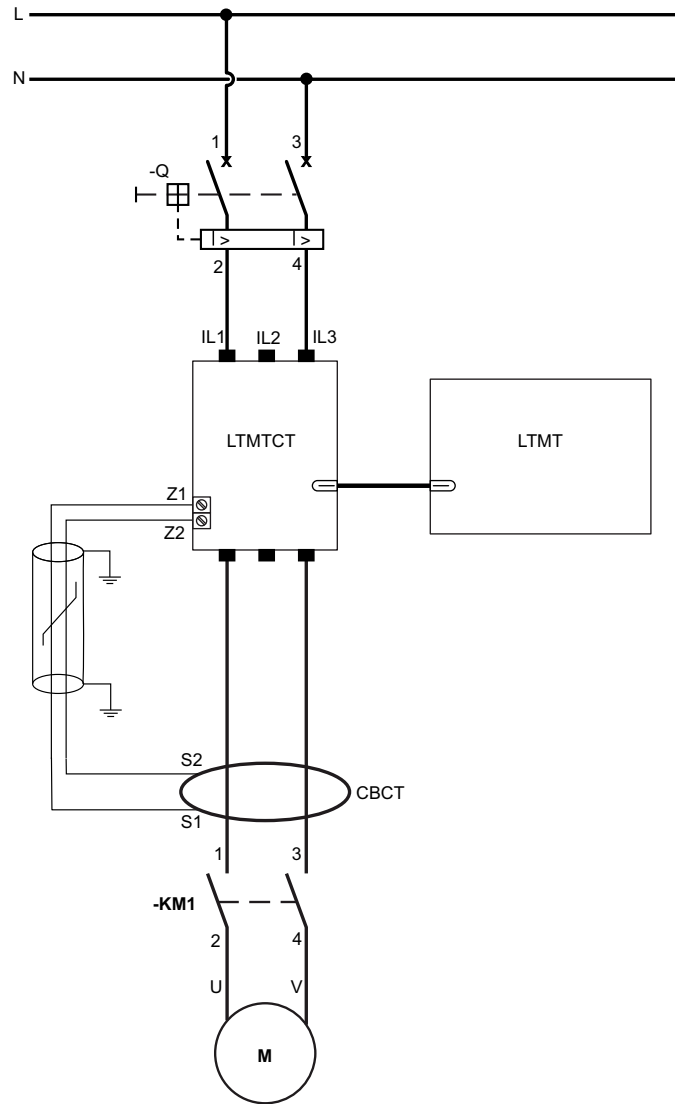

LTMTCTV Horizontal Sensor Modules for Three-Phase With Voltage

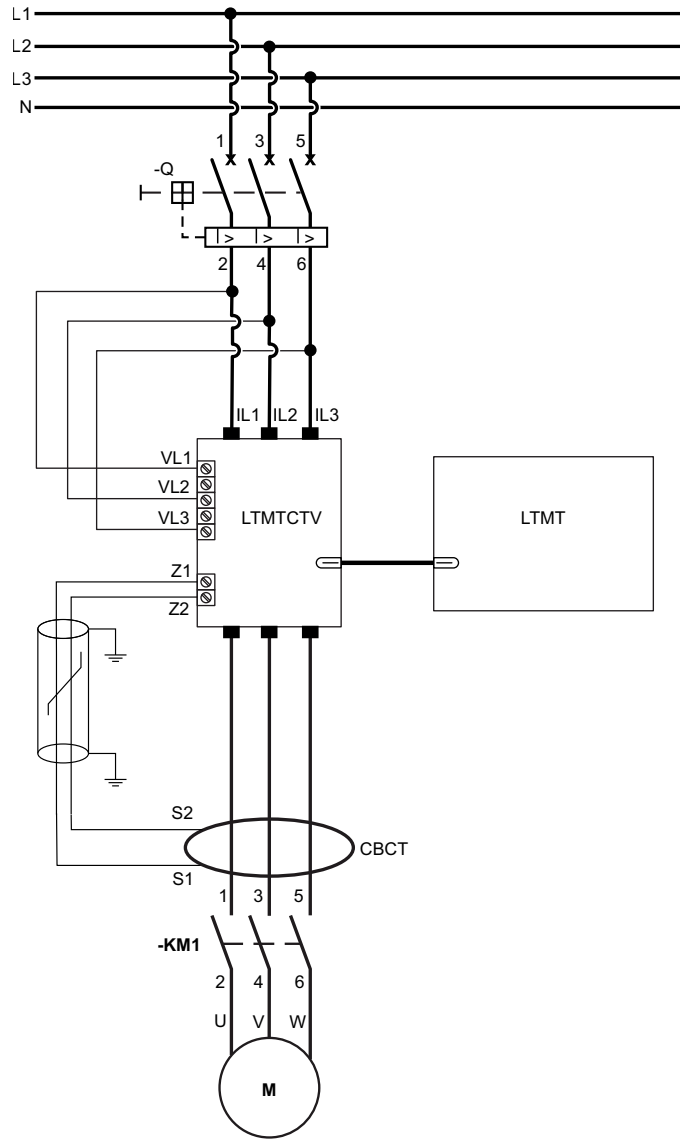

LTMTCTV Horizontal Sensor Modules for Single-Phase

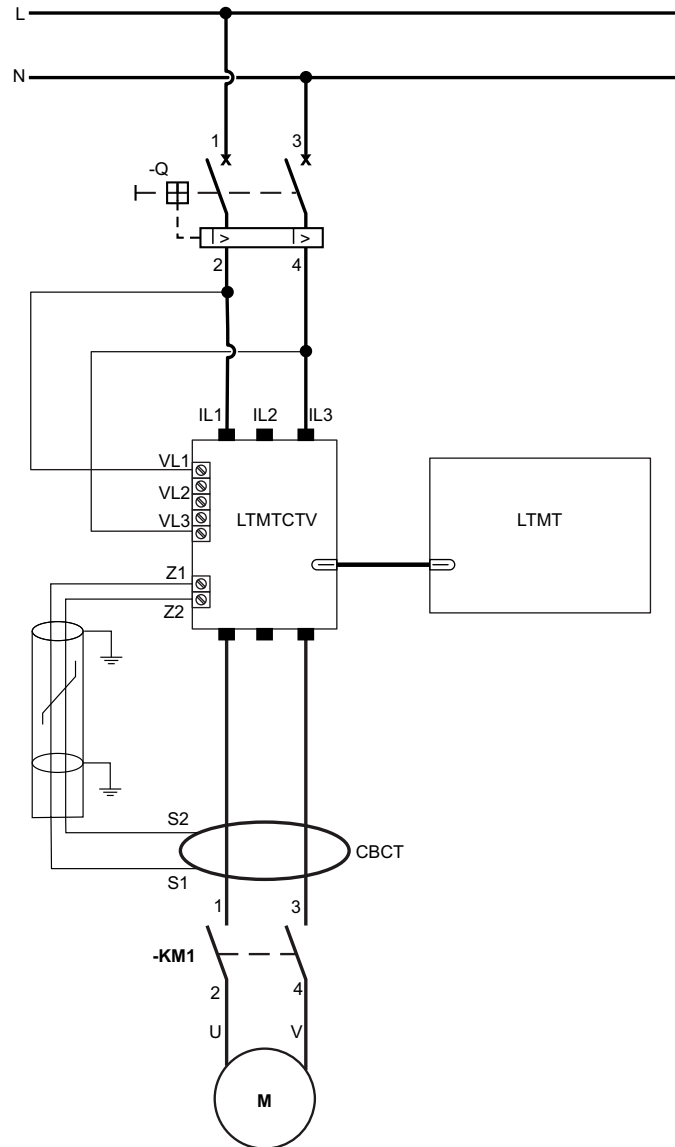

Internal Current Transformers Wiring Through the Windows

The following diagrams shows typical wiring using the CT windows for single-phase motor:

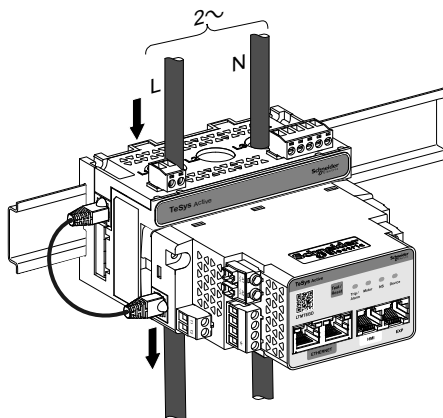

The following diagrams shows typical wiring using the CT windows for three-phase motor:

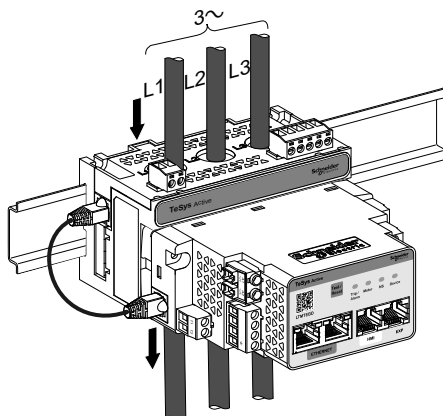

LTMTCT/LTMTCTV current range	Maximum wire cross-section
0.3–3 A	6 sqmm
2.5–25 A	10 sqmm
10–100 A	50 sqmm

Internal CT Wiring Using Multiple Passes

NOTICE

CONNECTION ERROR

The loop should be wired in the same direction through the CT sensor for all phases.

Failure to follow these instructions can result in equipment damage.

To determine the amount of current passing through the internal current sensors, multiply the current by the number of times the motor wires pass through the CT windows.

By allowing multiple passes, you can either increase the current sensed by the internal sensors to a level that the LTMT main unit can accurately detect or provide a more precise reading from the internal sensors.

We recommend selecting the LTMT Sensor Module with an full load current (FLC) value range that encompasses the motor FLC. However, if the motor FLC is lower than the FLC range of the LTMT Sensor Module making multiple passes can elevate the current level detected by the internal current sensors to a level the LTMT main unit can detect.

For instance, when using the LTMT Sensor Module with a FLC range of 0.3 to 3 A, and the motor FLC is 0.2 A, the LTMT main unit may not accurately detect the current. However, if you route the power wiring through the internal current sensors of the LTMT Sensor Module two times, the sensors will register a current of 0.4 A (2 passes x 0.2 A). This level is within the FLC range of the LTMT main unit, allowing for proper sensing.

The following diagram shows wiring of single-phase horizontal external load CT wiring:

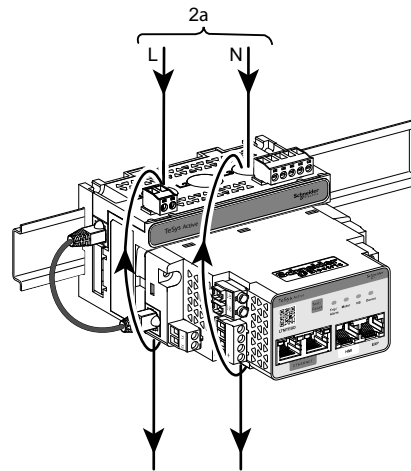

The following diagram shows wiring of three-phase horizontal external load CT wiring:

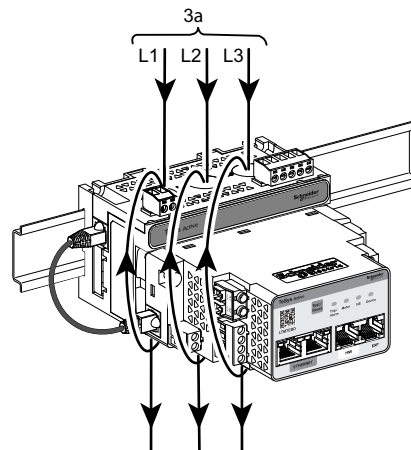

External CT Wiring

External CT are specified with a transformation ratio. The ratio of the external CT is the ratio of the motor input current to the CT output current.

The LTMTCT3/LTMTCTV3 sensor module accepts 1 A secondary signals from external current transformers.

The LTMTCT25/LTMTCTV25 sensor module accepts 5 A secondary signals from external current transformers.

To enable the LTMT main unit to adjust the FLC range and display the actual line current, set the following parameters:

- Phase CT Primary
- Phase CT Secondary (1 A or 5 A)

The following diagram shows wiring of single-phase motor using external CT:

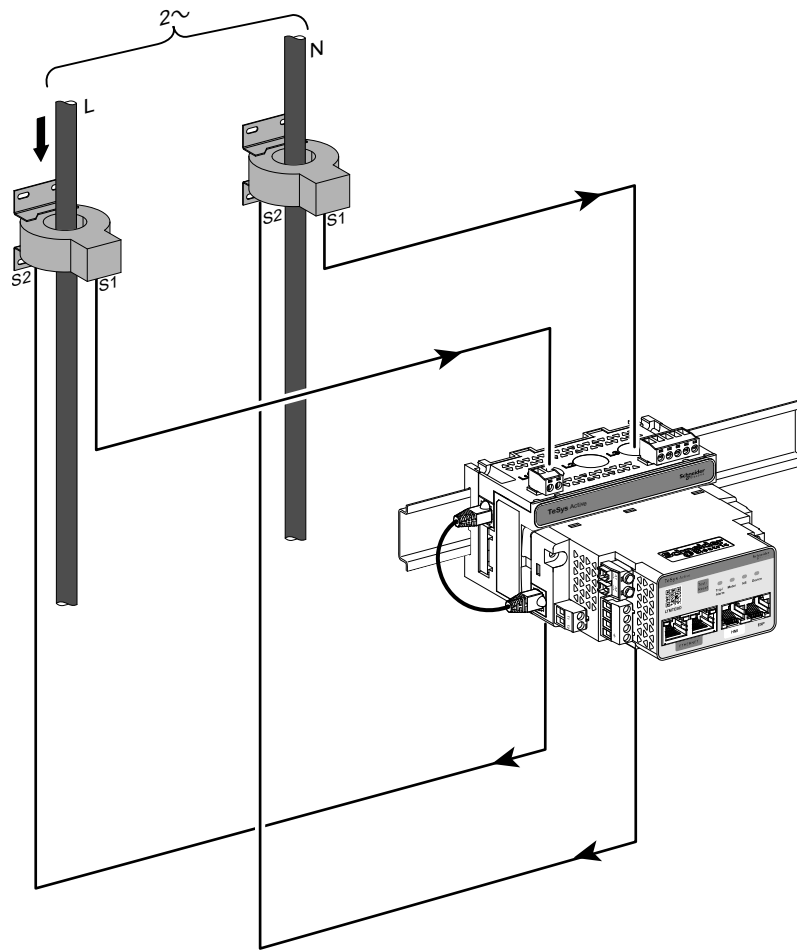

The following diagram shows wiring using three-phase motor external CT:

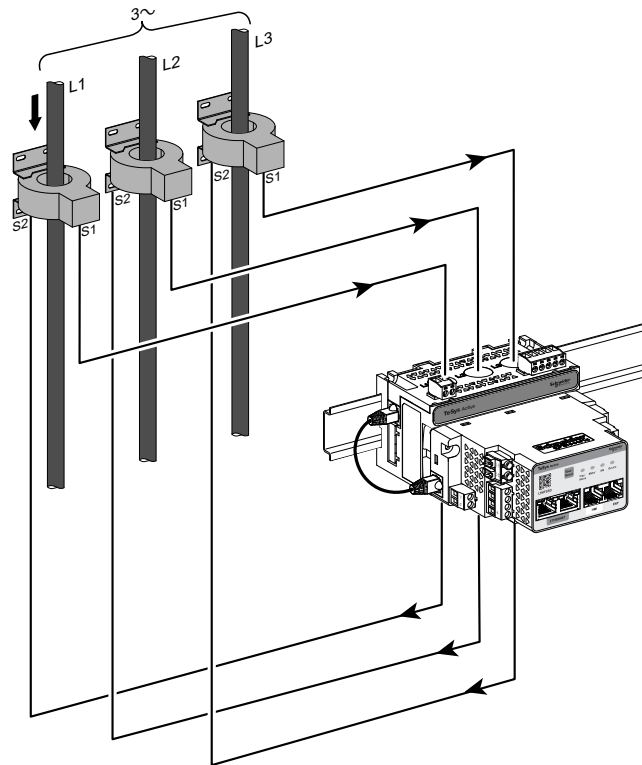

LTMTCTV Phase Voltage Input Terminals

The LTMTCTV sensor modules have a plug-in five-terminal connector for phase voltage inputs.

The terminal assignment is as follows:

- Single-phase voltage input terminal

Terminal	Description
L1	Phase 1 voltage input
Blank	Not used
L2	Not used
Blank	Not used
N	Phase N voltage input

- Three-phase voltage input terminal

Terminal	Description
L1	Phase 1 voltage input
Blank	Not used
L2	Phase 2 voltage input
Blank	Not used
L3	Phase 3 voltage input

For terminal wiring characteristics, refer to [Screw Terminal Wiring Characteristics](#), page 59.

LTMT Expansion Module Wiring

What's in This Chapter

4 Digital Inputs and 2 Digital Outputs (4DI+2DO) LTMT Expansion Module	85
2 Analog Inputs and 1 Analog Output (2AI+1AO) Expansion Module	87

4 Digital Inputs and 2 Digital Outputs (4DI+2DO) LTMT Expansion Module

The 4DI+2DO LTMT expansion module provides:

- Four isolated digital inputs.
- Two digital outputs with NO contacts.

The digital inputs are powered by an external power supply.

The references of the 4DI+2DO LTMT expansion module are:

- LTMTIN42FM: 4DI+2DO LTMT expansion module with 100–265 Vac/dc for IEC, 110–240 Vac/dc for UL.
- LTMTIN42BD: 4DI+2DO LTMT expansion module with 24 Vdc DI rating.

Up to five 4DI+2DO LTMT expansion module can be connected to one LTMT main unit.

Module Description

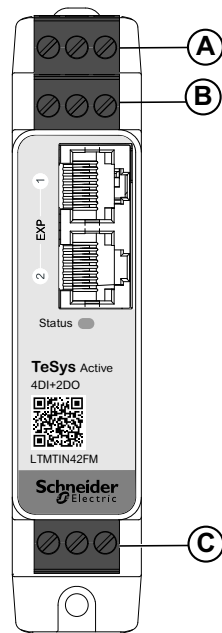

- A Digital inputs 5 and 6 connector
- B Digital inputs 7 and 8 connector
- C Digital outputs 1 and 2 connector

Wiring Diagram (Example)

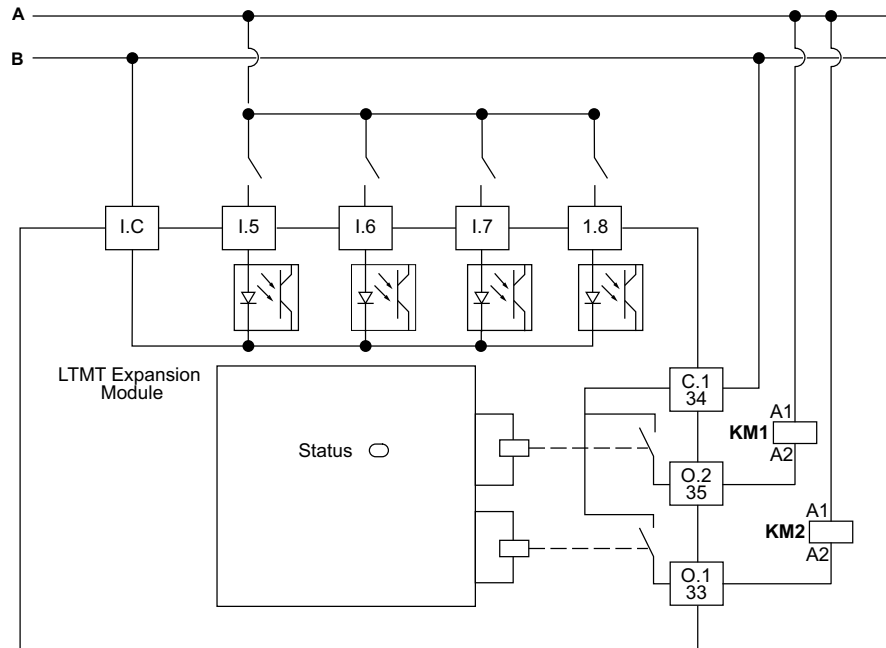

The terminal assignment is as follows for LTMT expansion module:

Connector	Terminal	Description
A (Digital inputs 5 and 6 connector)	I.5	Digital input 5
	I.C	Common for digital inputs
	I.6	Digital input 6
B (Digital inputs 7 and 8 connector)	I.7	Digital input 7
	–	No connection
	I.8	Digital input 8
C (Digital outputs 1 and 2 connector)	C.1	Common for digital output
	O.2	Digital Output 2 - Normally open contact
	O.1	Digital output 1 - Normally open contact

For more information on digital input wiring, refer to the Digital Inputs Wiring, page 92.

For more information on digital output wiring, refer to the Digital Outputs Wiring, page 97.

For terminal wiring characteristics, refer to the Screw Terminal Wiring Characteristics, page 59.

2 Analog Inputs and 1 Analog Output (2AI+1AO) Expansion Module

The LTMTAN21 expansion module provides:

- Two analog inputs 4–20 mA
- One analog output 4–20 mA

Up to two LTMTAN21 expansion modules can be connected to one LTMT main unit.

Module Description

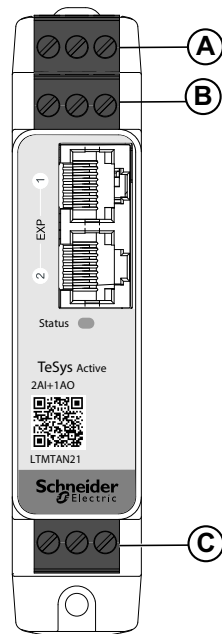

- A Analog input 1 (AI1) connector
- B Analog input 2 (AI2) connector
- C Analog output (AO) connector

Wiring Diagram (Example)

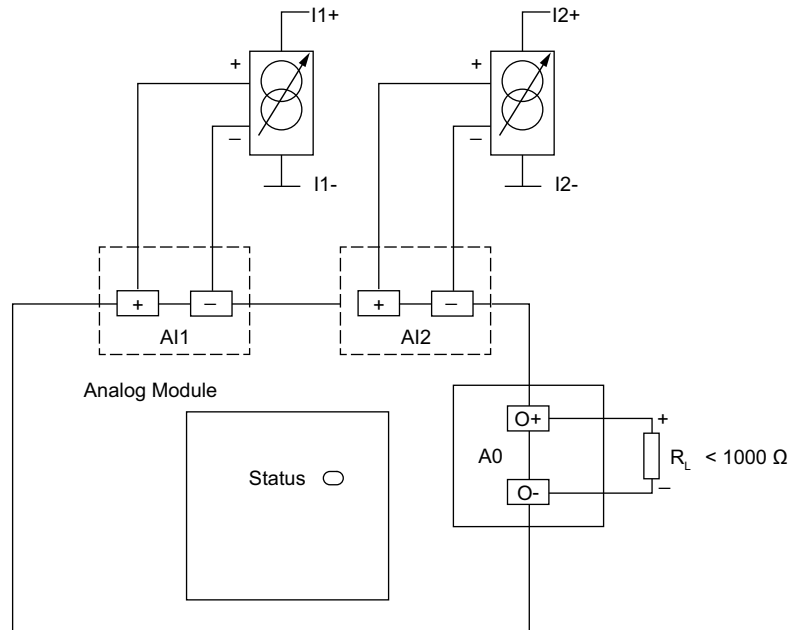

The terminal assignment is as follows for LTMT expansion module:

Connector	Terminal	Description
A (Analog input 1 connector)	I1+	Analog input 1 (+) terminal
		No connection
	I1-	Analog input 1 (-) terminal
B (Analog input 2 connector)	I2+	Analog input 2 (+) terminal
		No connection
	I2-	Analog input 2 (-) terminal
C (Analog output connector)	O+	Analog output (+) terminal
		No connection
	O-	Analog output (-) terminal

For terminal wiring characteristics, refer to *Screw Terminal Wiring Characteristics*, page 59.

Additional Wiring Instructions

What's in This Chapter

Power Supply Wiring	90
Digital Inputs Wiring.....	92
Digital Outputs Wiring	97

Power Supply Wiring

DC Power Supply

A dedicated 24 Vdc power supply is necessary to supply:

- One or several LTMT main unit including the digital inputs of the LTMT main units.
- The digital inputs of the LTMT expansion modules.

An additional specific 24 Vdc power supply is necessary to supply:

- LTMT main unit digital outputs
- Other devices

The LTMT main unit DC power supply must have the following characteristics:

- AC/DC converter
- Galvanic isolation input AC/output DC: 4 kVac minimum at 50 Hz
- SMPS input voltage: 100–240 Vac (+15%/-20%)
- SMPS output voltage: 24 Vdc (+/-10%)

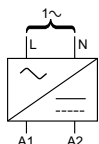

The following Schneider Electric ABL8RPS24... power supplies are recommended:

Reference number	Input voltage	Output voltage/ current	Maximum number of LTMT main units supplied
ABL8RPS24100	100–500 Vac	24 Vdc/10 A	25
ABL8RPS24050	100–500 Vac	24 Vdc/5 A	10
ABL8RPS24030	100–500 Vac	24 Vdc/3 A	5

AC Power Supply

A dedicated AC power supply or uninterruptible power supply (UPS) is necessary to supply:

- One or several LTMT main unit
- Digital inputs of the LTMT expansion module

An additional specific AC power supply is necessary to supply:

- LTMT main unit digital outputs
- Other devices

The LTMT main unit AC power supply or UPS must have the following characteristics:

- Isolation transformer
- Transformer output voltage: 115 or 230 Vac (+15%/-20%)
- 115 Vac output voltage is recommended
- Power according to the number of LTMT main unit (several AC supplies are recommended)

- UPS is recommended if voltage is unstable and does not follow standard EN 50160

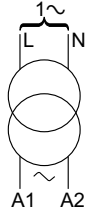

Digital Inputs Wiring

Digital Inputs of the LTMT Main Unit

The LTMT main unit has four digital inputs. For more information, refer to the LTMT main unit wiring, page 60 section:

- Available through I.1 to I.4 terminals.
- Internally powered by the LTMT main unit.

Digital Inputs of LTMT Expansion Module

LTMT expansion module have 4DI+2DO, which have four digital inputs.

The digital input supply voltage is 24 Vdc or 100–240 Vac/Vdc.

For more information, refer to the Power Supply Wiring, page 90.

Connection of the Digital Inputs

NOTICE

CONNECTION ERROR

- Maintain minimum 5 cm and maximum 10 cm gap between the control and power cables.
- Use potential free contact on LTMT main unit inputs.
- Respect the recommendations given in this chapter.

Failure to follow these instructions can result in equipment damage.

Three types of connection are possible:

- Direct connection for all information on digital inputs coming from the fixed and withdrawable MCC.
- Connection through interposing relays for all information on digital inputs coming from outside of the fixed and withdrawable MCC and LTMT main unit mainly, connected with long lines.
Using interposing relays minimizes EMC disturbance effects on the LTMT main unit and improves the reliability of the information.
- Connection without interposing relays for digital input on short distance of 300 m maximum.

For TeSys Tera inputs/outputs applications, only dry contacts free of potential can be used. Otherwise, current could be supplied to sensor or device and affect the input/output state.

Inductive Interference

For parallel cable runs above 100 m (328 ft) with close proximity between control and power cables, an induced voltage can be generated and cause the LTMT main unit to remain blocked. It is highly recommended to separate control and power cables with 50 cm (1.64 ft) space or use separation plate. To limit the induced voltage in AC, it is possible to add a clamping resistor in parallel of the interposing relay.

Maximum Distance Without Interposing Relay

The maximum distance allowed without interposing relay is addressed below:

Wire size	1 mm ² (AWG 17)	1.5 mm ² (AWG 16)	2 mm ² (AWG 14)	2.5 mm ² (AWG 14)
Maximum distance for wires	210 m (689 ft)	182 m (597 ft)	163 m (689 ft)	149 m (489 ft)

However, due to variability of installations it is highly recommended to use interposing relays for control cable lengths longer than 100 m (328 ft).

Recommended Interposing Relay

Interposing relays must have the following characteristics:

- Electromechanical main unit with 2.5 kVac isolation minimum.
- Self-cleaning or low level contact (I < 5 mA).
- Installed in the fixed and withdrawable MCC as close as possible to the LTMT main unit.
- AC or DC control circuit voltage, supplied by separate power supply (not supplied by the same power supply as the LTMT main unit to respect the galvanic isolation).

In case of long distances between the process and the LTMT main unit, interposing relays with DC control circuit voltage are recommended.

The protection module is mandatory on the interposing relays to suppress the surge.

The following Schneider Electric RSB1 interposing relays are recommended:

Reference number	Control circuit voltage	Protection module
RSB1A120•D	6, 12, 24, 48, 60, 110 Vdc	Diode RZM040W
RSB1A120•7	24, 48 Vac	RC circuit RZM041BN7
RSB1A120•7	120, 220, 230, 240 Vac	RC circuit RZM041FU7

Use of DC Interposing Relays

The DC interposing relays are recommended because long wires distances can be used to command the LTMT main unit.

DC RSB1 main unit voltage	24 Vdc	48 Vdc	110 Vdc
Maximum distance for wires in parallel without metallic shielding	3,000 m (10,000 ft)	3,000 m (10,000 ft)	3,000 m (10,000 ft)
Maximum distance for wires in parallel with metallic shielding	3,000 m (10,000 ft)	3,000 m (10,000 ft)	3,000 m (10,000 ft)

The following diagram shows an example when using DC interposing relays:

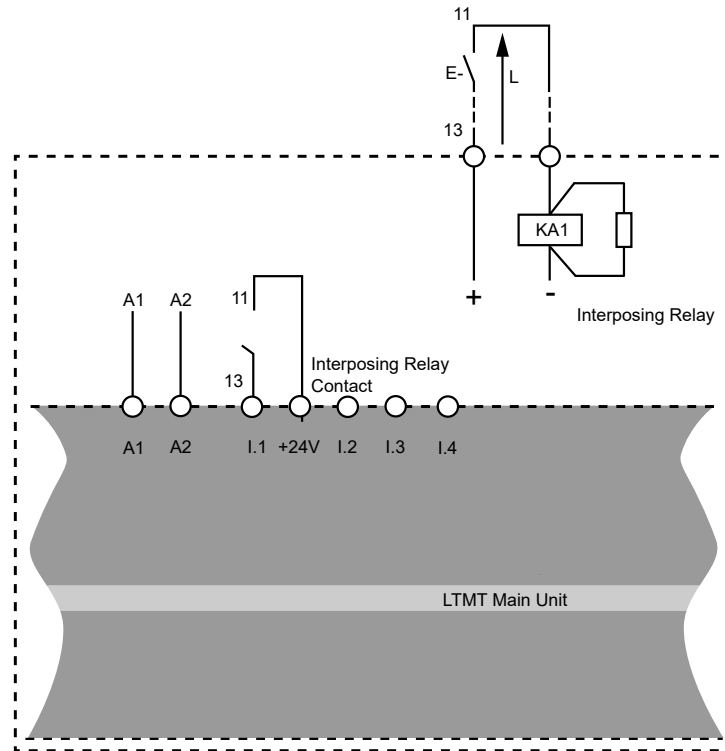

NOTE: Terminals 11 and 13 are potential free contact.

Use of AC Interposing Relays

The use of an AC interposing relay is allowed only for short distances if an AC voltage is mandatory.

AC RSB1 main unit voltage	24 Vac	48 Vac	120 Vac	230/240 Vac
Maximum distance for wires in parallel without metallic shielding	3,000 m (10,000 ft)	1,650 m (5,500 ft)	170 m (550 ft)	50 m (165 ft)
Maximum distance for wires in parallel with metallic shielding	2,620 m (8,600 ft)	930 m (3,000 ft)	96 m (315 ft)	30 m (100 ft)

The following diagram shows an example when using AC interposing relays:

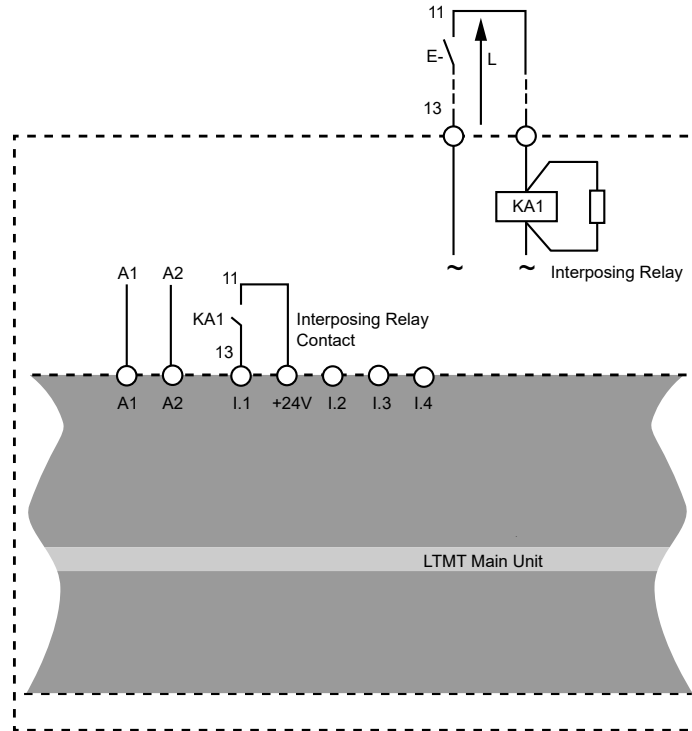

NOTE: Terminals 11 and 13 are potential free contact.

Use of AC Relays with a Rectifier

The use of AC relay with a rectifier is recommended on long distances if an AC voltage is mandatory.

Add a rectifier composed of 1 A/1,000 V diodes to command an AC relay. In this way, rectified AC current flows in the control cable when the switch in the continuous part is closed.

LTMT main unit drop out time increases with the stray capacitance (long cable length) because the capacitance minimizes the inductive behavior of the coil. The equivalent component tends to be a resistor increasing the drop-out time. Moreover, the more the voltage is high the more the phenomenon is important.

AC RSB1 main unit voltage	24 Vac	48 Vac	120 Vac	230/240 Vac
Maximum distance for wires in parallel without metallic shielding	3,000 m (10,000 ft)	3,000 m (10,000 ft)	3,000 m (10,000 ft)	3,000 m (10,000 ft)
Maximum distance for wires in parallel with metallic shielding	3,000 m (10,000 ft)	3,000 m (10,000 ft)	3,000 m (10,000 ft)	3,000 m (10,000 ft)

The following diagram shows an example when using AC interposing relays with a rectifier:

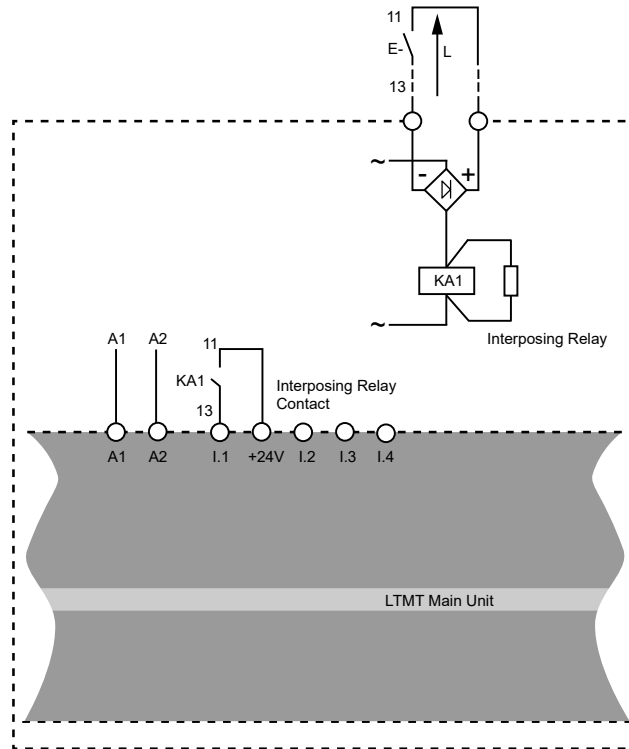

NOTE: Terminals 11 and 13 are potential free contact.

Digital Outputs Wiring

NOTICE

INOPERABLE EQUIPMENT

The peelable label indicates that the Normally Open (NO) contact will switch to close position when transported or subjected to heavy vibration.

Failure to follow these instructions can result in equipment damage.

Digital Outputs of the LTMT Main Unit

The three digital outputs of the LTMT main unit are relay outputs.

The three relay outputs on the LTMT main unit are:

- Two NO relay outputs, available on O.1/13, C.1/14, and O.2/23 terminals
- One NO+NC relay output, available on NO, O3/C2, and NC terminals

Digital Outputs of the LTMT Expansion Modules

LTMT expansion module 4DI+2DO have two digital outputs.

The digital output supply voltage is 24 Vdc or 240 Vac/Vdc.

The digital outputs of the LTMT expansion module are NO relay outputs.

Interposing Relay for Tesys Tera Digital Outputs

When an output commands of contactor, an interposing relay may be required depending of the coil voltage and the power required by the contactor used.

The LTMT main unit digital output characteristics are:

- Rated insulation voltage: 300 V
- AC rated thermal load: 250 Vac/5 A
- DC rated thermal load: 30 Vdc/5 A
- AC 15 rating: 480 VA, 500,000 operations, $I_e \text{ max} = 2 \text{ A}$
- DC 13 rating: 30 W, 500,000 operations, $I_e \text{ max} = 1.25 \text{ A}$

If the LTMT main unit digital output is not able to control the contactor directly, an interposing relay is required.

The protection module is mandatory on the interposing relays to suppress the surge.

Commissioning

What's in This Part

Introduction.....	99
First Power-up of the LTMT Main Unit (Control Circuit)	101
First Setup Parameters	102
Additional Parameters	104
Verifying System Wiring	105
Verify Configuration	108
First Motor Power-up	109

Introduction

⚠ WARNING

UNINTENDED EQUIPMENT OPERATION

- The application of the TeSys Tera system requires expertise in the design and programming of control systems. Only personnel with such expertise should be allowed to program, install, configure, alter, and apply this product.
- Follow all local and national safety codes and standards.

Failure to follow these instructions can result in death, serious injury, or equipment damage.

Overview

Commissioning must be performed after the physical installation of the TeSys Tera system and other hardware devices.

The commissioning process includes:

- Initialization of the installed devices.
- Configuration of the TeSys Tera system and other system hardware.

Familiarity with the system hardware, installation, and application usage is essential during commissioning.

Hardware devices can include:

- Motor or Heater
- Voltage transformers
- External load current transformers
- Ground current sensors
- Communication network

The product specifications for these devices provide the required parameter information. An understanding of how the TeSys Tera system will be utilized to configure the protection, monitoring, and control functions for the application is necessary.

For information about configuring protection and control parameters, refer to the *TeSys Tera Motor Management System User Guide – DOCA0257***, page 9.

For information about the configuration of the communication network, refer to the appropriate guides:

- *TeSys Tera Motor Management System Modbus RTU Communication Guide – DOCA0355***, page 9
- *TeSys Tera Motor Management System PROFIBUS DP Communication Guide – DOCA0256***, page 9
- *TeSys Tera Motor Management System EtherNet/IP Communication Guide - DOCA0258***, page 9

Initialization

The TeSys Tera system is ready to be initialized after the hardware installation is complete.

▲ CAUTION

EQUIPMENT DAMAGE

Disconnect power to the motor/heater before initializing the TeSys Tera system.

Failure to follow these instructions can result in injury or equipment damage.

To initialize the TeSys Tera system:

1. Verify that the command to control the motor is off.
2. Verify that the LTMT9RJ1015 or LTMT9RJ105 or LTMT9RJ102 RJ11 cable is connected to the LTMT main unit and LTMTCT/LTMTCTV sensor module.
3. Verify that the LTMT9RJ401 RJ45 cable is connected to the LTMT main unit and LTMT expansion module.
4. Turn on the LTMT main unit.

Configuration Tools

Identify the configuration control source and the configuration tool before configuring the parameters.

The TeSys Tera system can be configured using:

- A PC running the TeSys Tera DTM embedded in a FDT container like SoMove software
- The LTMTCUF control operator unit
- A PLC or DCS through the communication network

For more information on TeSys Tera Ethernet configuration using web-pages, refer *TeSys Tera Motor Management System EtherNet/IP Communication Guide - DOCA0258***, page 9.

Commissioning Process

The commissioning process remains the same, regardless which configuration tool you select. This process includes the following stages:

Stage	Description
First power-up of the LTMT main unit (control circuit)	The TeSys Tera system initializes, and is ready for parameter configuration. For more information, refer to the <i>First Power-up of the LTMT Main Unit (Control Circuit)</i> , page 101.
Configuring required settings	Configure these parameters to move the TeSys Tera system out of its initialization state. The TeSys Tera system is ready for operations. For more information, refer to the <i>First Setup Parameters</i> , page 102.
Configuring optional settings	Configure these parameters to support the TeSys Tera system functions required by the application. For more information, refer to the <i>Additional Parameters</i> , page 104.
Verifying hardware	Check hardware wiring. For more information, refer to the <i>Verifying System Wiring</i> , page 105.
Verifying the configuration	Confirm accurate parameter settings. For more information, refer to the <i>Verify Configuration</i> , page 108.
First motor power-up	Check the phase rotation. For more information, refer to the <i>First Motor Power-up</i> , page 109.

First Power-up of the LTMT Main Unit (Control Circuit)

Overview

First power-up describes the first time power is cycled to:

- A new LTMT main unit, or
- An LTMT main unit that has been previously commissioned, however whose parameter settings have been restored to the default values either as a result of:
 - Action on the LTMT main unit reset button, to return to the default values.
 - Factory reset can be performed through reset button on:
 - LTMTCUF control operator unit
 - LTMT main unit (Press **Test/Reset** button for 10 s)
 - While performing factory settings store the data before reconnecting to the device.

NOTE: After turn on the LTMT main unit, device LED will glow after 30 s only in EtherNet/IP protocol.

For more information, refer to the Factory reset command in the *TeSys Tera Motor Management System LTMTCUF Control Operator Unit User Guide – DOCA0233••*.

First Setup Parameters

The TeSys Tera system required parameters can be configured by using:

- A PC running the TeSys Tera DTM embedded in a FDT container such as SoMove software: go to **Parameter List > General Settings** to configure the required parameters.

For more information, refer to the *TeSys Tera Motor Management System DTM Library Online Help Guide – DOCA0275***, page 9.

- The LTMTCUF control operator unit has default **Pin**. Change the **Pin** before any modification and login to LTMTCUF control operator unit. For more information on setting **Pin**, refer *TeSys Tera Motor Management System LTMTCUF Control Operator Unit User Guide – DOCA0233***, page 9.
- The LTMTCUF control operator unit: navigate **Menu > First Setup** to configure the required parameters.

Configure the required parameters in the following order:

1. Device configuration
2. Starter settings
3. System settings
4. Communication settings
5. Date time settings

- The device configuration, starter settings, and system settings are described in the user guide. For more information, refer to the *TeSys Tera Motor Management System User Guide – DOCA0257***, page 9.
- The communication settings are described in user guide. For more information, refer to the *TeSys Tera Motor Management System User Guide – DOCA0257***, page 9.

For more information on TeSys Tera Ethernet configuration using web-pages, refer *TeSys Tera Motor Management System EtherNet/IP Communication Guide - DOCA0258***, page 9.

Device Configuration

The device configuration consists of selecting:

- Reference of the LTMTCT/LTMTCTV sensor module, LTMT expansion module connected to the LTMT main unit.
- Temperature type configuration of LTMT main unit.

The device configuration are described in the user guide. For more information, refer to the *TeSys Tera Motor Management System User Guide – DOCA0257***, page 9.

After configuring the references of the modules connected to the LTMT main unit, the device LED on the LTMT main unit must be green in color.

If the device LED on the LTMT main unit is not green in color, use the TeSys Tera DTM and navigate to **Diagnostics > Diagnostic Data > Device Internal Status** to correct the error detected.

If the device LED on the LTMT main unit is green and no errors are detected, the other required parameters can be configured.

For more information on TeSys Tera Ethernet configuration using web-pages, refer *TeSys Tera Motor Management System EtherNet/IP Communication Guide - DOCA0258***, page 9.

Starter Settings

The starter type configured by default is **Direct Online**. If another starter type is required, then select the required starter type from the list of starter types. If you change the starter settings, the device will reboot.

To set the other starter settings, refer to the *TeSys Tera Motor Management System User Guide – DOCA0257***, page 9.

System Settings

The system settings configure:

- System characteristics (nominal voltage, nominal current, nominal frequency, and nominal power).
- Motor characteristics (full load current, phase rotation).
- External CT characteristics.

To set the system settings, refer to the *TeSys Tera Motor Management System User Guide – DOCA0257***, page 9

Communication Settings

The communication settings of the device can be configured through:

- A PC running the TeSys Tera DTM embedded in a FDT container such as SoMove software.
- The LTMTCUF control operator unit.
- A PLC or DCS through the communication.

To set the communication settings, refer to the following guides:

- *TeSys Tera Motor Management System Modbus RTU Communication Guide – DOCA0355***, page 9
- *TeSys Tera Motor Management System PROFIBUS DP Communication Guide – DOCA0256***, page 9.
- For more information on TeSys Tera Ethernet configuration using web-pages, refer *TeSys Tera Motor Management System EtherNet/IP Communication Guide - DOCA0258***, page 9.

Additional Parameters

Introduction

In addition to the first setup parameters, configure the below parameters if required at first power-up or later:

- Protection settings
- I/O Settings

For more information, refer to the *TeSys Tera Motor Management System User Guide – DOCA0257***, page 9.

LTMTCUF Control Operator Unit

In the LTMTCUF control operator unit, first setup and other parameters are located in the sub-menus of the Menu.

TeSys Tera DTM

In the TeSys Tera DTM, first setup and other parameters are located in tree view items in the **My Device > Parameters List** tab.

Verifying System Wiring

Overview

After all the required and optional parameters have been configured, be sure to check your systems wiring, which can include:

- Motor or Heater power wiring
- LTMT main unit wiring
- External current transformer wiring
- Diagnostic wiring
- I/O wiring

Motor Power Wiring

To verify the motor power wiring, check the following:

Look at...	Action
The motor nameplate	Confirm that the motor generates current and voltage within the ranges of the LTMTCT/LTMTCTV sensor module.
The power wiring diagram	Visually confirm that the actual power wiring matches the intended power wiring, as described in the power wiring diagram.
The list of trips and alarms with the TeSys Tera DTM or with the LTMTCUF control operator unit	<p>Look for the following trips or alarms:</p> <ul style="list-style-type: none"> • Current and voltage phase reversal • Current and voltage phase imbalance • Current and voltage phase loss • Over/under current • Over/under voltage • Over power • Under power • Under power factor • Thermal overload • Locked rotor • Stall rotor <p>The presence of trips or alarms can be related to settings or wiring fault.</p>
The list of parameters with the TeSys Tera DTM or with the LTMTCUF control operator unit	<p>Look for unexpected values in the following parameters:</p> <ul style="list-style-type: none"> • Active power • Reactive power • Power factor <p>The presence of unexpected values can be related to settings or wiring fault.</p>
The list of No voltage inhibit and under voltage inhibit parameter in TeSys Tera DTM or on LTMTCUF control operator unit	<p>Look for the unexpected values:</p> <ul style="list-style-type: none"> • L1- L2 RMS voltage • L2-L3 RMS voltage • L3-L1 RMS voltage • Average voltage <p>The presence of unexpected values can be related to settings or wiring fault.</p>

NOTE: Compatible firmware version must be available during the commissioning process.

Control Circuit Wiring

To verify control circuit wiring, visually confirm that the actual control wiring matches the intended control wiring, as described in the control wiring diagram.

For more information, refer to the Logic Test Mode in the *TeSys Tera Motor Management System User Guide – DOCA0257***, page 9.

If the LED indication is different from expected, use the TeSys Tera DTM and go to:

- **Diagnostic > Records > Device Internal**
- **Diagnostics > Diagnostics data > Alarm/Trip Status** to consult the list of active trip and alarm events.
- Check the inhibit status:
 - If the control wiring is not working as expected
 - If you cannot start/stop the motor

There are multiple inhibit causes, for more information, refer to Inhibit Status section in the *TeSys Tera Motor Management System User Guide – DOCA0257***, page 9.

Current Transformer Wiring

Verify the load current transformer wiring and, if the application includes external load current transformers, also verify that wiring by checking the following:

Look at...	Action
The external CT wiring diagram	Visually confirm that the actual wiring matches the intended wiring, as described in the wiring diagram.
The following external CT parameter settings, using either the TeSys Tera DTM or the LTMTCUF control operator unit: <ul style="list-style-type: none"> • Phase CT primary • Phase CT secondary • Phase CT secondary passes 	Confirm that the external CT parameter settings, accurately reflect the intended external CT ratio.
The following system parameter setting, using either the TeSys Tera DTM or the LTMTCUF control operator unit: Phase rotation.	Visually check that the phase wiring sequence matches the motor phase rotation parameter setting.

Diagnostic Wiring

Verify the wiring for any temperature sensing device or external ground current sensor, if the application includes these devices, by checking the following:

Look at...	Action
The wiring diagram	Visually confirm that the actual wiring matches the intended wiring, as described in the wiring diagram.
The external ground CT specifications	Confirm the wiring is proper and select the required CT.
The specifications of the temperature sensor connected to the LTMT main unit.	Confirm that the temperature sensor actually connected to the LTMT main unit is the same sensor type as set in the temperature sensor parameters.

I/O Wiring

Verify the wiring for any I/O connections by checking the following:

Look at...	Action
The wiring diagram	Visually confirm that the actual wiring matches the intended wiring, as described in the wiring diagram.
<p>The AUX1 (Run 1), AUX2 (Run 2), and Stop buttons on the LTMTCUF control operator unit</p> <p>- and -</p> <p>The following parameter setting, using either the TeSys Tera DTM or the LTMTCUF control operator unit: Starter, digital input, and digital output settings.</p>	Confirm that each command performs the intended start or stop function, when control is via the terminal strip or the HMI port.
<p>The Reset button on the LTMTCUF control operator unit</p> <p>- and -</p> <p>The following parameter setting, using either the TeSys Tera DTM or the LTMTCUF control operator unit: Reset mode of protection setting as HMI or Reset Key.</p>	Confirm that the LTMTCUF control operator unit can command a manual trip reset.
<p>The PLC or DCS, if the LTMT main unit is connected to a network</p> <p>- and -</p> <p>The following parameter setting, using either the TeSys Tera DTM or the LTMTCUF control operator unit: Starter and reset mode of protection settings.</p>	Confirm that the PLC or DCS can command the intended start, stop and remote reset functions.

Verify Configuration

Overview

The final step in the commissioning process is to verify that all configurable parameters used in the application are properly configured.

When performing this task, a reference list of all the parameters to be configured and the desired settings is required. It is imperative to compare this list against the actual settings of the configured parameters.

Process

Verifying parameter settings is a three-part process:

1. Transfer the configuration file from the LTMT main unit to the PC running the TeSys Tera DTM. This allows to view the LTMT main unit present parameter settings.

For information on transferring files from the LTMT main unit to the PC, refer to the *TeSys Tera Motor Management System DTM Library Online Help Guide – DOCA0275***, page 9 for FDT Container.

2. Compare the reference list of intended parameters and settings against the same settings located in the **Parameters List** tab in TeSys Tera DTM Library. SoMove software displays a list of modified settings in the **Parameters List** tab, providing a quick way to view the configured parameters.

3. Change the configuration settings as desired. Do this using:

- Enter the TeSys Tera DTM, then download the edited file from the PC to the LTMT main unit.

For information on transferring files from the PC to the LTMT main unit, refer to the *TeSys Tera Motor Management System DTM Library Online Help Guide – DOCA0275***, page 9 for FDT Container.

- Or LTMTCUF control operator unit: to edit parameters located in the Menu, navigate to the sub-menu settings and make the appropriate edits.

First Motor Power-up

To power-up the motor, follow these steps:

1. Activate the test logic mode system setting.

NOTE: The device LED will flash in green.

2. Perform motor start, stop operations (without motor power supply that is, no voltage).
3. Make any required adjustments, if required.
4. Deactivate the test logic mode.
5. Power up the motor to test motor starter.
6. Check that the inhibit causes are switched off.
7. Initiate motor start from the configured control modes using different inputs.

Maintenance

What's in This Part

Detecting Problems	112
Troubleshooting	115
Preventive Maintenance	116
Replacing LTMT Main Unit, LTMTCT/LTMTCTV Sensor Module, and LTMT Expansion Module.....	120
Communication Alarms and Trips	122

Overview

This chapter describes the maintenance and self-diagnostic features of the TeSys Tera system.

▲ WARNING

UNINTENDED EQUIPMENT OPERATION

- The application of the TeSys Tera system requires expertise in the design and programming of control systems. Only trained personnel with such expertise should be allowed to program, install, alter, and apply this product.
- Follow all local, national safety codes, and standards.

Failure to follow these instructions can result in death, serious injury, or equipment damage.

Detecting Problems

Overview

The LTMT main unit and LTMT expansion module perform self-diagnostic checks at power-up and during operation.

Problems with either the LTMT main unit or LTMT expansion module can be detected using:

- Device and alarm LED on the LTMT main unit
- Status LED on the LTMT expansion module
- LTMT main unit

LTMT Main Unit Status LED

LED name	Status (Color Indication)	Possible cause	Action
Device	Off	LTMT main unit is inoperative.	<ul style="list-style-type: none"> • Check the power supply and wiring • Replace the LTMT main unit, if the device is not turned on
	Green on	LTMT main unit is healthy.	–
	Green blinking	LTMT main unit in Logic test mode.	<ul style="list-style-type: none"> • Check if the logic test mode is enabled and Logic test DI input is on. • Check the module is undergoing firmware upgrade.
	Red on	LTMT main unit configuration error detected.	Check the status of device internal in TeSys Tera DTM. To troubleshoot respective error detection, refer to the Troubleshooting, page 115.
	Red blinking	LTMT main unit and LTMT Sensor Module communication error detected or configuration error detected. LTMT main unit and LTMT expansion module communication error detected.	Check the connection between the LTMT main unit and LTMT Sensor Module. Check the connection between LTMT main unit and LTMT expansion module.
			To troubleshoot respective error detection, refer to the Troubleshooting, page 115 section.
	Fallback (LTMT ^{••} and LTMTM ^{••})	–	
Green and Red flashing	Ethernet available from power-on until the application starts running	–	
Green flashing	<ul style="list-style-type: none"> • During the auto firmware upgrade check • During firmware update is in progress • Sedp package verification 	–	
Motor	Off	Motor in Inhibit state	Check the inhibit status in DTM. For more information, refer to the <i>TeSys Tera Motor Management System DTM Library Online Help Guide – DOCA0275^{••}</i> , page 9
	Green on	Motor in Stop state, ready to Start	–
	Green blinking	Motor is running	–

LED name	Status (Color Indication)	Possible cause	Action
Trip/Alarm	Off	No trip or alarm condition	–
	Blue blinking	Alarm condition is present	Check alarm status in DTM. For more information, refer to the <i>TeSys Tera Motor Management System DTM Library Online Help Guide – DOCA0275**</i> , page 9
	Blue on	Pickup condition is present	Check the event records.
	Red blinking	LTMT main unit has tripped and trip condition is still present. Trip cannot be reset.	Check the trip status or trip records in DTM and remove the trip condition which is active.
	Red on	LTMT main unit has tripped and trip condition is not present. Trip can be reset.	Reset the trip.
NS ⁽⁴⁾	Off	Device is either not powered on, does not have an IP address, or is using a fallback IP address	–
	Steady green on	Configured client is connected and IO connection is established	–
	Green flashing	IP address is configured but no IO connections are established	Check the communication between TeSys Tera with PLC or DCS.
	Red flashing	Communication loss or connection time out	–
	Flashing green or red once	During device power up self-test is performed	–
LK ⁽⁴⁾	Off	No connection established	–
	Yellow steady	Link	–
	Yellow blinking	Activity	–
ACT ⁽⁴⁾	Off	10 Mbps speed	–
	Green steady	100 Mbps speed	–
Comm ⁽⁵⁾	Off	Communication is not established with PLC or DCS.	Check the communication between TeSys Tera with PLC or DCS.
	Green on	Communication is established with PLC or DCS.	–
	Red blinking	Communication is lost with PLC or DCS.	Check the communication between TeSys Tera with PLC or DCS.

⁽⁴⁾ LED is available only with EtherNet/IP and Modbus TCP/IP protocol
⁽⁵⁾ LED is only for Modbus RTU and PROFIBUS DP protocol

LTMT Expansion Module Status LED

LED status	Possible cause	Action
Off	LTMT expansion module is inoperative.	<ul style="list-style-type: none"> Check the cable and connection between LTMT main unit and LTMT expansion module. Change the LTMT expansion module or contact Schneider Electric front office.
Red blinking	<ul style="list-style-type: none"> LTMT main unit is not communicating. Firmware update is in progress. 	<ul style="list-style-type: none"> Check the device configuration. Check the detected LTMT expansion module on DTM > My device tab. Change the LTMT expansion module. Update the firmware.
Red on	LTMT expansion module device internal or configuration detected error.	<ul style="list-style-type: none"> Check the device configuration. Check the detected LTMT expansion module on DTM > My device tab. Change the LTMT expansion module.
Green on	LTMT expansion module is ready and communicating with LTMT main unit.	<ul style="list-style-type: none"> Check the device configuration. Check the detected LTMT expansion module on DTM > My device tab. LTMT expansion module is healthy.

TeSys Tera DTM

TeSys Tera DTM displays a visual array of active trips and alarms, including LTMT main unit self-diagnostic trips and alarms, when these trips occur.

For information about this display of active trips and alarms, refer to the *TeSys Tera Motor Management System DTM Library Online Help Guide – DOCA0275••*, page 9.

Troubleshooting

Self-Diagnostic Tests

The LTMT main unit carries out a series of self tests at power-up and during operation. Following steps to take in response to a error detected are described below:

Type	Error Detected	Action
Major Device Internal Error Detection	Sensor module communication error detected	<ol style="list-style-type: none"> 1. Check the RJ11 LTMT9RJ105 or LTMT9RJ1015 or LTMT9RJ102 is added and connected properly between LTMT main unit and Sensor module. 2. Check detected LTMT Sensor Module on TeSys Tera DTM My Device tab. 3. Replace RJ11 LTMT9RJ105 or LTMT9RJ1015 or LTMT9RJ102 and check. 4. Check whether any loose connection of the LTMT9RJ105/LTMT9RJ1015 cable. 5. Replace sensor module and check. 6. Replace LTMT main unit.
	LTMT expansion module communication error detected	<ol style="list-style-type: none"> 1. Check device configuration setting for LTMT expansion module. Check detected LTMT expansion module on DTM My Device tab. 2. Check the RJ45 LTMT9RJ401 is connected properly between LTMT main unit and LTMT expansion module. 3. Replace RJ45 LTMT9RJ401 and check. 4. Replace LTMT expansion module and check. 5. Replace LTMT main unit.
	Configuration error detected	<ol style="list-style-type: none"> 1. Check device configuration setting for LTMT expansion module and CT sensor module. 2. Check detectedLTMT expansion module on DTM my device tab. 3. Make correct configuration and check.
	Internal temperature is high	Replace LTMT main unit.
Minor Device Internal Error Detection	–	Contact Schneider Electric's support team.

Preventive Maintenance

Overview

The following protective measures should be performed between major system checks, to help maintain the system and protect it against irrecoverable hardware or software with detected failures:

- Continuously review operating statistics.
- Save LTMT main unit parameter configuration settings to a backup file.
- Maintain the LTMT main unit operating environment. For more information, refer to the *TeSys Tera Motor Management System - Catalog*.
- Periodically perform a LTMT main unit self test.
- Check the LTMT main unit internal clock to ensure accuracy.

Statistics

The LTMT main unit collects the following types of information:

- Real-time voltage, current, power, temperature, and I/O data.
- Count of the number of trips, by trip type, that occurred since last power-up.
- Time-stamped history of the state of the LTMT main unit (displaying measures of voltage, current, power, and temperature) at the moment that each of the previous 20 trips occurred.

Use either the DTM or the LTMTCUF control operator unit to access and review these statistics. Analyze this information to determine whether the actual record of operations indicates a problem.

Configuration Settings

In the event of irrecoverable LTMT main unit error detection, you can quickly restore configuration settings if you have saved these settings to a file. When the LTMT main unit is first configured, and every subsequent time any configuration settings are changed, use the TeSys Tera DTM to save the parameter settings to a file.

To save a configuration file, Select **File > Save As...**

To restore the saved configuration file:

1. Open the saved file: Select **File > Open** (then navigate to the file).
2. Download the configuration to the new LTMT main unit.
3. Select **Communication > Store to Device**.

Environment

Like any other electronic device, the TeSys Tera system is affected by its physical environment. Provide an environment by taking common-sense preventive measures, including:

- Scheduling periodic examinations of battery packs, fuses, power strips, batteries, surge suppressors, and power supplies.
- Keeping the TeSys Tera system, the panel, and all devices clean. An unobstructed flow of air will prevent dust build-up, which can lead to a short-circuit condition.
- Remaining alert to the possibility of other equipment producing electromagnetic radiation. Be sure no other devices cause electromagnetic interference with the TeSys Tera system.

Self Test Without Trip

Press **Reset** button for 3 to 15 s to perform a self test without trip. When the button is released, the LTMT main unit LED will turn on in pattern1 for 1 second. After 1 second, the LTMT main unit LED will turn on in pattern2 for 1 second. After 2 seconds from the beginning of the test, LTMT main unit comes out of the test mode.

LED	Pattern 1 LED status	Pattern 2 LED status
Device	●	●
Comm	●	●
NS	●	●
Motor Status	●	○
Trip/Alarm	●	●

The graphical representation of self test mode without trip is as follows:

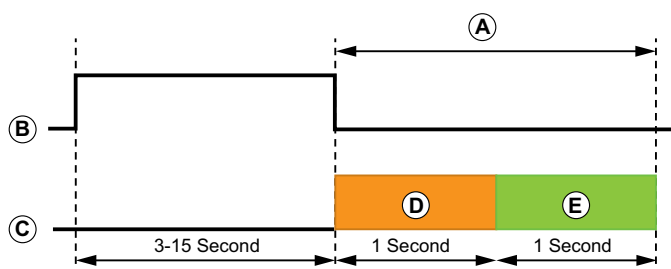

- A Self test mode without trip
- B Reset button
- C LEDs and LCD
- D Pattern1
- E Pattern2

Self Test With Trip (If Motor is Stopped)

When a self test with trip command is received from LTMTTCUF control operator unit or communication network or a digital input of the LTMT main unit:

- The LTMT main unit LEDs will turn on in pattern1 for 1 s. After 1 s, the LTMT main unit LEDs will turn on in pattern 2 for 1 s.
- The state of the trip digital output changes for 2 s.
- After 2 s from the beginning of the test, the LTMT main unit comes out of the test mode, and the state of the trip digital output will change.

LEDs	Pattern 1 LED status	Pattern 2 LED status
Device	●	●
Motor Status	●	●
Comm	●	●
NS	●	○
Trip/Alarm	●	●

The graphical representation of self test mode with trip is as follows:

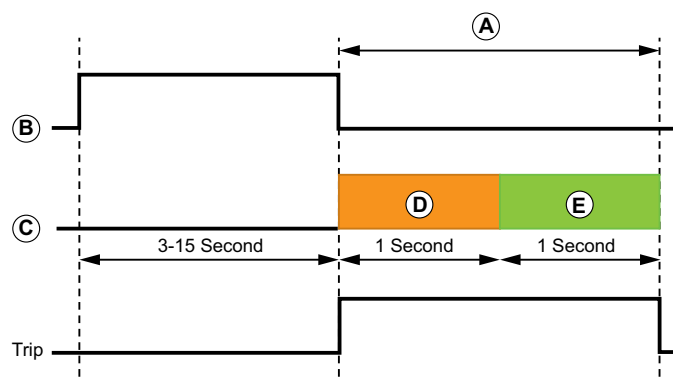

- A Self test mode with trip
- B Reset button
- C LEDs and LCD
- D Pattern1
- E Pattern2

Internal Clock

For accurate record of trips, the LTMT main unit internal clock must be synchronized regularly. The LTMT main unit time stamps all events, using the value stored in the Date And Time Setting parameter.

The date and time can be set in the LTMT main unit by using:

- TeSys Tera DTM
- LTMTCUF control operator unit
- Communication network
- Network time protocol (NTP) server (only for Ethernet protocol)

Internal clock accuracy is ± 1 s per hour. If power is continuously applied for one year, the internal clock accuracy is ± 30 m per year.

If power is turned off for 12 hours or less, the LTMT main unit retains its internal clock settings, with accuracy of ± 2 m.

If power is turned off for more than 12 hours, the LTMT main unit resets its internal clock to the default time.

When Ethernet device reboots, the date and time return to default date and time.

NOTE: When the LTMT main unit is turned off, the system time resets. To restore the time, it must be synchronized with an NTP server in EtherNet/IP protocol.

Replacing LTMT Main Unit, LTMTCT/LTMTCTV Sensor Module, and LTMT Expansion Module

Overview

Questions to consider in advance of replacing either an LTMT main unit, LTMTCT/LTMTCTV sensor module or an LTMT expansion module are:

- Is the replacement device the same reference model as the original?
- Have the configuration settings of the LTMT main unit been saved, and are they available to be transferred to its replacement?
- Do we have to check the firmware of modules too?

NOTE: Single-phase and three-phase power supply to be turned off, before replacing either the LTMT main unit, LTMTCT/LTMTCTV sensor module or the LTMT expansion module.

Replacing the LTMT Main Unit

The time to plan for the replacement of an LTMT main unit is:

- When the LTMT main unit settings are initially configured.
- Any time that one or more of its settings are subsequently re-configured.

Setting values may not be accessible when the LTMT main unit is replaced. For example, in case of device hardware detected failure, you should create a record of setting values whenever they are made.

Using the TeSys Tera DTM Library, all of the LTMT main unit configured settings, except for date and time, can be saved to a file. Once saved, you can use the TeSys Tera DTM Library to transfer these settings either to the original LTMT main unit or to its replacement.

NOTE: Only configured settings are saved. Historical statistical data is not saved, and therefore cannot be applied to a replacement LTMT main unit.

LTMTCUF Fast Device Replacement (FDR) services facilitate the replacement of a drawer in a high continuity of service environment, without needing a PC or expertise in configuring LTMT main unit.

For more information on FDR, refer to *TeSys Tera Motor Management System LTMTCUF Control Operator Unit User Guide – DOCA0233***, page 9

For information on how to use the TeSys Tera DTM Library to create, save and transfer configuration setting files, refer to the *TeSys Tera Motor Management System DTM Library Online Help Guide – DOCA0275***, page 9.

Replacing the LTMTCT/LTMTCTV Sensor Module

The primary consideration in replacing an LTMTCT/LTMTCTV sensor module, is to replace it with the same model as the original.

Replacing the LTMT Expansion Module

The primary consideration in replacing an LTMT expansion module, is to replace it with the same model, 24 Vdc or 100-240 Vac, as the original.

Firmware During Replacement

Follow the process for the firmware during replacement:

- Turn off the device before replacing the LTMT expansion module or LTMTCT/LTMTCTV sensor module.
- Disconnect the existing and connect the new module. After installing the new module, turn On the device. If the firmware on the new module is not compatible with the LTMT main unit, the LTMT main unit automatically update the firmware. The firmware update may take some time.

Retiring Devices

Both the LTMT main unit and the LTMT expansion module contain electronic boards that require particular treatment at the end of their useful life. When retiring a device, be sure to observe all applicable laws, regulations, and practices.

Communication Alarms and Trips

Introduction

Communication alarms and trips are managed in a standard way, like any other types of alarms and trips.

The presence of a trip is signaled by various indicators:

- State of the communication LED on LTMT main unit
- Alarm
- Message(s) displayed on LTMTCUF control operator unit

Network Communication Loss

A communication loss is managed like any other trip. For more information, refer to *TeSys Tera Motor Management System User Guide – DOCA0257***, page 9.

HMI Communication Loss

HMI Communication loss Function:

- Detects the loss of communication between the LTMT main unit and the LTMTCUF control operator unit connected through the HMI port, once communication has been established.
- Generates an alarm or a trip action according to the function setting.

Parameter Setting

Parameter	Range	Default Value
Function	<ul style="list-style-type: none"> • Disable • Alarm • Trip • Alarm and Trip 	Disable
Time delay	0.1 – 6000.0 s in ste of 0.1s	1 s
Reset mode	<ul style="list-style-type: none"> • Auto • Reset Key • DI • Communication 	Reset Key + DI
Auto Rest delay	0.0 – 6000.0 s in step of 0.1 s	0.0 s

Schneider Electric Industries SAS
35 rue Joseph Monier
92500 Rueil Malmaison
France

www.se.com

As standards, specifications, and design change from time to time, please ask for confirmation of the information given in this publication.

© 2025 Schneider Electric. All rights reserved.

DOCA0356EN-01