

TeSys Active

TeSys Tera Motor Management System

Substitution Guide

TeSys offers innovative and connected solutions for motor starters.

DOCA0278EN-00
03/2026

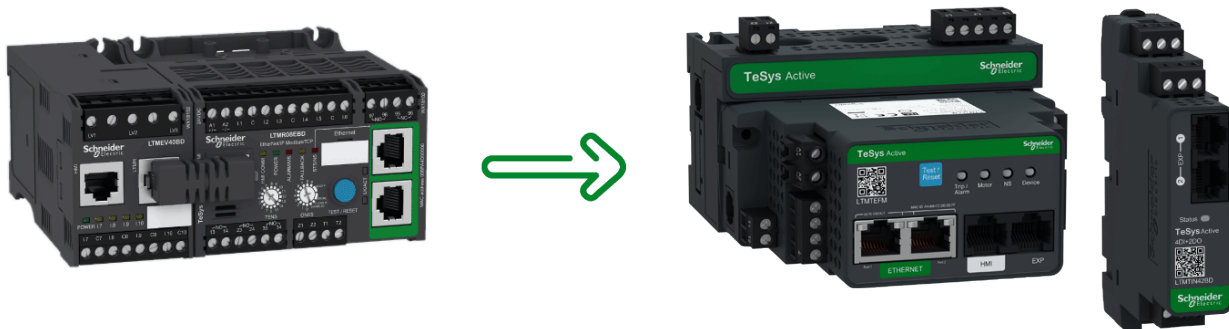

Legal Information

The information provided in this document contains general descriptions, technical characteristics and/or recommendations related to products/solutions.

This document is not intended as a substitute for a detailed study or operational and site-specific development or schematic plan. It is not to be used for determining suitability or reliability of the products/solutions for specific user applications. It is the duty of any such user to perform or have any professional expert of its choice (integrator, specifier or the like) perform the appropriate and comprehensive risk analysis, evaluation and testing of the products/solutions with respect to the relevant specific application or use thereof.

The Schneider Electric brand and any trademarks of Schneider Electric SE and its subsidiaries referred to in this document are the property of Schneider Electric SE or its subsidiaries. All other brands may be trademarks of their respective owner.

This document and its content are protected under applicable copyright laws and provided for informative use only. No part of this document may be reproduced or transmitted in any form or by any means (electronic, mechanical, photocopying, recording, or otherwise), for any purpose, without the prior written permission of Schneider Electric.

Schneider Electric does not grant any right or license for commercial use of the document or its content, except for a non-exclusive and personal license to consult it on an "as is" basis.

Schneider Electric reserves the right to make changes or updates with respect to or in the content of this document or the format thereof, at any time without notice.

To the extent permitted by applicable law, no responsibility or liability is assumed by Schneider Electric and its subsidiaries for any errors or omissions in the informational content of this document, as well as any non-intended use or misuse of the content thereof.

Table of Contents

Safety Information.....	5
About the Document.....	6
Precautions.....	10
Introduction.....	12
TeSys T Motor Management System.....	13
TeSys Tera Motor Management System.....	15
TeSys T to TeSys Tera Substitution.....	19
TeSys T to TeSys Tera Commercial References.....	20
Physical Device Replacement.....	22
Equivalent Starter Types or Operating Modes.....	31
Equivalent Data Addresses	32
Equivalent Modbus Data Addresses.....	33
Equivalent EtherNet/IP Data Addresses.....	39
Functionality Difference Between TeSys T System and TeSys Tera System.....	40

Safety Information

Important Information

Read these instructions carefully, and look at the equipment to become familiar with the device before trying to install, operate, service, or maintain it. The following special messages may appear throughout this documentation or on the equipment to warn of potential hazards or to call attention to information that clarifies or simplifies a procedure.



The addition of this symbol to a “Danger” or “Warning” safety label indicates that an electrical hazard exists which will result in personal injury if the instructions are not followed.



This is the safety alert symbol. It is used to alert you to potential personal injury hazards. Obey all safety messages that follow this symbol to avoid possible injury or death.

DANGER

DANGER indicates a hazardous situation which, if not avoided, **will result in** death or serious injury.

WARNING

WARNING indicates a hazardous situation which, if not avoided, **could result in** death or serious injury.

CAUTION

CAUTION indicates a hazardous situation which, if not avoided, **could result in** minor or moderate injury.

NOTICE

NOTICE is used to address practices not related to physical injury.

Please Note

Electrical equipment should be installed, operated, serviced, and maintained only by qualified personnel. No responsibility is assumed by Schneider Electric for any consequences arising out of the use of this material.

A qualified person is one who has skills and knowledge related to the construction and operation of electrical equipment and its installation, and has received safety training to recognize and avoid the hazards involved.

About the Document

Document Scope

This substitution guide provides the information necessary for the replacement of TeSys T system with the TeSys Tera system.

Validity Note

This document is valid for substituting the TeSys T system with the TeSys Tera system.

The availability of some functions described in this document depends on the communication protocol used and the physical modules installed on the TeSys T system.

General Cybersecurity Information

In recent years, the growing number of networked machines and production plants has seen a corresponding increase in the potential for cyber threats, such as unauthorized access, data breaches, and operational disruptions. You must, therefore, consider all possible cybersecurity measures to help protect assets and systems against such threats.

To help keep your Schneider Electric products secure and protected, it is in your best interest to implement the cybersecurity best practices as described in the *Cybersecurity Best Practices* document.

Schneider Electric provides additional information and assistance:

- Subscribe to the Schneider Electric [security newsletter](#).
- Visit the [Cybersecurity Support Portal](#) web page to:
 - Find Security Notifications.
 - Report vulnerabilities and incidents.
- Visit the [Schneider Electric Cybersecurity and Data Protection Posture](#) web page to:
 - Access the cybersecurity posture.
 - Learn more about cybersecurity in the cybersecurity academy.
 - Explore the cybersecurity services from Schneider Electric.

Product Related Cybersecurity Information

Refer to *TeSys Tera Motor Management System Cybersecurity Guide – DOCA0260EN*.

Available Languages of the Document

The document is available in these languages:

- English
- French
- Spanish
- German
- Italian
- Chinese
- Korean

Related Documents

TeSys T documents:

Title of Documentation	Description	Reference Number
TeSys T LTMR - Motor Management Controller - Installation Guide	This guide describes the installation, commissioning, and maintenance of the TeSys T LTMR motor management controller and LTME expansion module.	DOCA0128EN
TeSys T LTMR - Motor Management Controller - Ethernet Communication Guide	This guide describes the Ethernet network protocol version of the TeSys T LTMR motor management controller and LTME expansion module.	DOCA0129EN
TeSys T LTMR - Motor Management Controller - Modbus Communication Guide	This guide describes the Modbus network protocol version of the TeSys T LTMR motor management controller and LTME expansion module.	DOCA0130EN
TeSys T LTMR - Motor Management Controller - PROFIBUS DP Communication Guide	This guide describes the PROFIBUS DP network protocol version of the TeSys T LTMR motor management controller and LTME expansion module.	DOCA0131EN
TeSys T LTMR - Motor Management Controller - CANopen Communication Guide	This guide describes the CANopen network protocol version of the TeSys T LTMR motor management controller and LTME expansion module.	DOCA0132EN
TeSys T LTMR - Motor Management Controller - DeviceNet Communication Guide	This guide describes the DeviceNet network protocol version of the TeSys T LTMR motor management controller and LTME expansion module.	DOCA0133EN
TeSys® T LTM CU - Control Operator Unit - User Manual	This manual describes how to install, configure, and use the TeSys T LTM CU Control Operator Unit.	1639581EN
Compact Display Units - Magelis XBT N/XBT R - User Manual	This manual describes the characteristics and presentation of the XBT N/XBT R display units.	1681029EN
TeSys T LTMR Ethernet/IP with a Third-Party PLC - Quick Start Guide	This guide provides a single reference for configuring and connecting the TeSys T and the Allen-Bradley programmable logic controller (PLC).	DOCA0119EN
TeSys T LTM R Modbus - Motor Management Controller - Quick Start Guide	This guide uses an application example to describe the different steps to quickly install, configure, and use TeSys T for Modbus network.	1639572EN
TeSys T LTM R Profibus-DP - Motor Management Controller - Quick Start Guide	This guide uses an application example to describe the different steps to quickly install, configure, and use TeSys T for PROFIBUS-DP network.	1639573EN
TeSys T LTM R CANopen - Motor Management Controller - Quick Start Guide	This guide uses an application example to describe the different steps to quickly install, configure, and use TeSys T for CANopen network.	1639574EN
TeSys T LTM R DeviceNet - Motor Management Controller - Quick Start Guide	This guide uses an application example to describe the different steps to quickly install, configure, and use TeSys T for DeviceNet network.	1639575EN
Electromagnetic Compatibility - Practical Installation Guidelines	This guide provides an insight to the electromagnetic compatibility.	DEG999EN

Title of Documentation	Description	Reference Number
TeSys T LTM R•• - Instruction Sheet	This document describes the mounting and connection of the TeSys T LTMR motor management controller.	AAV7709901
TeSys T LTM E•• - Instruction Sheet	This document describes the mounting and connection of the TeSys T LTME expansion module.	AAV7950501
XBT N/R/RT - Instruction Sheet	This document describes the mounting and connection of the Magelis XBT-N.	1681014
TeSys T LTM CU• - Instruction Sheet	This document describes the mounting and connection of the TeSys T LTMCU control unit	AAV6665701
TeSys T DTM for FDT Container - Online Help	This online help describes the TeSys T DTM and the custom logic editor embedded in the TeSys T DTM which allows the customization of the control functions of the TeSys T motor management system.	1672614EN
TCSMCNAM3M002P USB to RS485 converter - Quick Reference Guide	This guide describes the configuration cable between computer and TeSys T: USB to RS485	BBV28000
Electrical Installation Guide (Wiki version)	The aim of the Electrical Installation Guide (and now Wiki) is to help electrical designers and contractors to design electrical installations according to standards such as the IEC60364 or other relevant standards.	www.electrical-installation.org

TeSys Tera documents:

Title of documentation	Description	Reference number
TeSys Tera Motor Management System Catalog	The catalog: <ul style="list-style-type: none"> • Describes the TeSys Tera system • Contains the TeSys Tera technical characteristics 	LVCATENTER
TeSys Tera Motor Management System User Guide	This is the main user guide that introduces the complete TeSys Tera system. It describes the main functions of the LTMT main units, LTMTCT/LTMTCTV sensor modules, LTMT expansion modules, and LTMTCUF control operator unit.	DOCA0257EN
TeSys Tera Motor Management System Installation Guide	This guide describes the installation, commissioning, and maintenance of the LTMT main units, LTMTCT/LTMTCTV sensor modules, LTMT expansion modules, and LTMTCUF control operator unit.	DOCA0356EN
TeSys Tera Motor Management System Modbus RTU Communication Guide	This guide describes the Modbus network protocol communication of the LTMT main unit.	DOCA0355EN
TeSys Tera Motor Management System PROFIBUS DP Guide	This guide describes the PROFIBUS DP network protocol communication of the LTMT main unit.	DOCA0256EN
TeSys Tera Motor Management System EtherNet/IP Guide	This guide describes the EtherNet network protocol communication of the LTMT main unit.	DOCA0258EN
TeSys Tera Motor Management System LTMTCUF Control Operator Unit User Guide	This guide describes how to install, configure, and use the LTMTCUF control operator unit.	DOCA0233EN
TeSys Tera Motor Management SystemDTM Library Online Help Guide	This online help provides the summary of the TeSys Tera DTM Library which allows the customization of the functions of the TeSys Tera motor management system.	DOCA0275EN
TeSys Tera Motor Management System DTM Library Software Release Note	This document provides important information about the TeSys Tera DTM Library software and provides summary of new features and enhancement.	DOCA0279EN
TeSys Tera Motor Management System Firmware Release Note	This document provides information about firmware package versions of the TeSys Tera system and provides summary of new features and enhancement.	DOCA0276EN

You can download these technical publications and other technical information from our website at www.se.com/www/en/download/.

Information on Non-Inclusive or Insensitive Terminology

As a responsible, inclusive company, Schneider Electric is constantly updating its communications and products that contain non-inclusive or insensitive terminology. However, despite these efforts, our content may still contain terms that are deemed inappropriate by some customers.

Trademarks

QR Code is a registered trademark of DENSO WAVE INCORPORATED in Japan and other countries.

Precautions

Read and understand the following precautions before performing any procedures in this guide.

⚡⚠ DANGER
HAZARD OF ELECTRIC SHOCK, EXPLOSION, OR ARC FLASH
<ul style="list-style-type: none">• This equipment must only be installed and serviced by qualified electrical personnel.• Turn off all power supplying this equipment before working on or inside this equipment.• Use only the specified voltage when operating this equipment and any associated products.• Always use a properly rated voltage sensing device to confirm power is off.• Use appropriate interlocks where personnel and/or equipment hazards exist.• Power line circuits must be wired and protected in compliance with local and national regulatory requirements.• Apply appropriate personal protective equipment (PPE) and follow safe electrical work practices per NFPA 70E, NOM-029-STPS, or CSA Z462 or local equivalent.
Failure to follow these instructions will result in death or serious injury.

⚠ WARNING
UNINTENDED EQUIPMENT OPERATION
<ul style="list-style-type: none">• Do not disassemble, repair, or modify this equipment. There are no user serviceable parts.• Install and operate this equipment in an enclosure appropriately rated for its intended application environment.• Each implementation of this equipment must be individually and thoroughly tested for proper operation before being placed into service.
Failure to follow these instructions can result in death, serious injury, or equipment damage.

Qualified Personnel

Only appropriately trained personnel who are familiar with and understand the content of this guide and all other related product documentation are authorized to work on and with this product.

The qualified personnel must be able to detect possible hazards that may arise from modifying parameter values and generally from mechanical, electrical, or electronic equipment. The qualified personnel must be familiar with the standards, provisions, and regulations for the prevention of industrial accidents, which they must observe when designing and implementing the system.

The use and application of the information contained in this guide requires expertise in the design and programming of automated control systems. Only you, the user, panel builder, or integrator, can be aware of all the conditions and factors present during installation, setup, operation, and maintenance of a process plant or machine, and can therefore determine the automation and associated equipment and the related safeties and interlocks which can be effectively and properly used when selecting automation and control equipment, and any other related equipment or software, for a particular application. You must also consider applicable local, regional, or national standards and/or regulations.

Pay particular attention to conformance with any safety information, electrical requirements, and normative standards that apply to your process plant or machine in the use of this equipment.

Intended Use

The products described in this guide, together with software, accessories, and options, are a part of starters for low-voltage electrical loads, intended for industrial use according to the instructions, directions, examples, and safety information contained in the present document and other supporting documentation.

The product may only be used in compliance with all applicable safety regulations and directives, the specified requirements, and the technical data.

Before using the product, you must perform a risk assessment of the planned application. Based on the results, appropriate safety-related measures must be implemented.

Since the product is used as a component of a process plant or machine, you must ensure the safety of person by means of the overall system design.

Operate the product only with the specified cables and accessories. Use only genuine accessories and spare parts.

Any use other than the use explicitly permitted is prohibited and can result in unanticipated hazards.

Introduction

What's in This Part

TeSys T Motor Management System	13
TeSys Tera Motor Management System	15

TeSys T Motor Management System

Overview

The TeSys T motor management system offers protection, control, and monitoring capabilities for single-phase or three-phase AC induction motors.

The system is flexible, modular, and can be configured to meet the requirements of applications in industry. The system is designed to meet the needs of integrated protection systems with open communications and a global architecture.

Highly accurate sensors and solid-state full motor protection provide better utilization of the motor. Complete monitoring functions enable the analysis of motor operating conditions and faster responses to prevent system downtime.

The system offers diagnostic and statistical functions, configurable alarms, and trips, allowing better prediction of component maintenance, and provides data to continuously improve the entire system.

Components of the TeSys T System

The main hardware components of the TeSys T system are LTMR controller, LTME expansion module, and LTMCU/LTMCUF control operator unit.

The microprocessor-based LTMR controller is the central component in the system to manage the control, protection, and monitoring functions of single-phase or three-phase AC induction motors.

The LTME expansion module provides voltage monitoring functionality and four additional logic inputs. The LTME expansion module is powered by the LTMR controller via a connector cable.

The LTMCU/LTMCUF control operator unit is an HMI device with a liquid crystal display and contextual navigation keys. The LTMCU/LTMCUF control operator unit is internally powered by the LTMR controller.

The system can be configured and controlled by using:

- HMI (Human Machine Interface) device: Magelis™ XBT or TeSys T LTMCU/LTMCUF
- PC running SoMove software with the TeSys T DTM library
- PLC connected to the system through the communication network

Naming Conventions of LTMR Controller

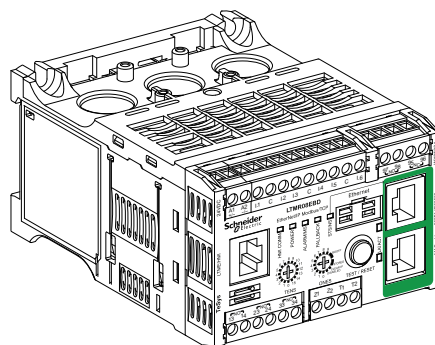

The reference number of the LTMR controller is defined based on the ampere rating, communication protocol, and control voltage of the LTMR controller.

The following tables describe the LTMR controller reference number: LTMRxxyzz or LTMRxxxzyz

xx\xxx	Rating
08	0.4–8 A
27	1.36–27 A
100	5–100 A

y	Communication Protocol
E	Ethernet (Modbus/TCP and Ethernet/IP)
M	Modbus SL
P	PROFIBUS DP
C	CANopen
D	DeviceNet

zz	Control Voltage
BD	24 Vdc
FM	100–240 Vac

Naming Conventions of LTME Expansion Module

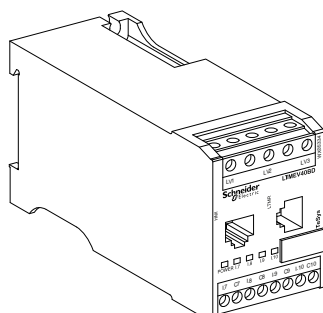

The reference number of the LTME expansion module is defined based on the control voltage of the controller.

The following table describes the LTME expansion module reference number: LTMEV40xx

xx	Control Voltage
BD	24 Vdc
FM	100–240 Vac

The components such as the control operator unit, load current transformers, ground current sensors, and cables add additional range to the TeSys T system.

The TeSys T system is configured and controlled by SoMove software, which is a Microsoft Windows® based application, using the open FDT/DTM technology.

SoMove software contains many DTM. A specific DTM software exists for the TeSys T motor management system.

NOTE: For more details about the components and the control software of the TeSys T system, refer to *TeSys T User Guide – DOCA0127EN*.

TeSys Tera Motor Management System

Overview

The TeSys Tera Motor Management System (or TeSys Tera system) is part of the TeSys Active range of intelligent relays and motor starters. The TeSys Tera system is designed as a reliable building block for Intelligent Motor Control Centres (iMCCs) to provide complete protection, metering, control, and monitoring capabilities for single-phase or three-phase AC induction motors.

The TeSys Tera system is installed in the low voltage switchgear system and connects the higher level automation system via fieldbus network and the motor feeder.

TeSys Tera system:

- Covers conventional and advanced motor protection, metering, and monitoring in iMCC feeders into single, easy to configure, compact communicating module with a display.
- Provides protection controller for low voltage contactor-controlled motor starter feeders.
- Provides flexible and modular motor management system for motors with constant speeds in low voltage applications.

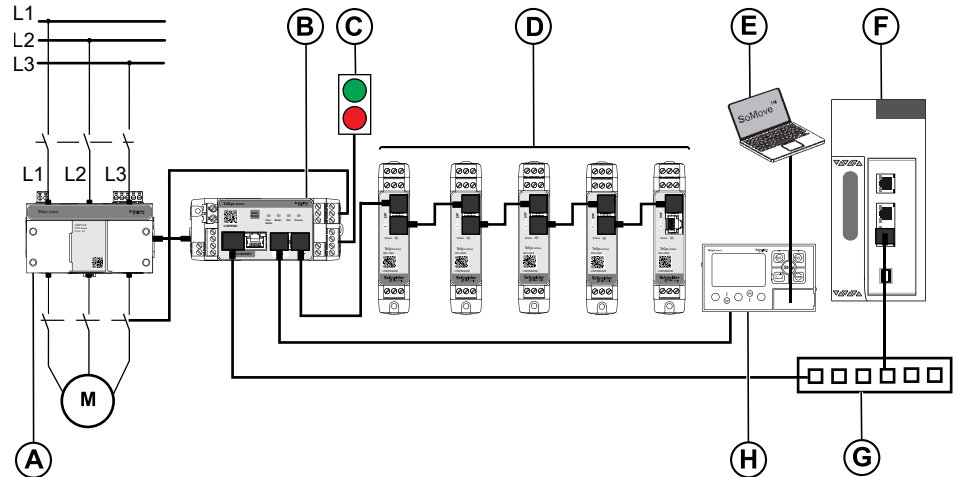

- A LTMTCT/LTMTCTV sensor module
- B LTMT main unit
- C Start/Stop commands
- D LTMT expansion modules
- E PC running SoMove FDT container software with TeSys Tera DTM installed.
- F Programmable Logic Controller (PLC) or Distributed Control System (DCS)
- G Communication network
- H LTMTCUF control operator unit

Functional Characteristics

The TeSys Tera system manages:

- Single-phase or three-phase AC induction motors and heaters rated up to 100 A and 690 V operational voltage, with an integral sensor module.
- Single-phase or three-phase AC induction motors and heaters rated up to 810 A and 690 V operational voltage, with external current transformers.

- The connection between the control system and the motor feeder, increases plant availability.
- Significant savings to the installation, commissioning, operation, and maintenance.
- Numerical microprocessor equipped controller that allows to set parameters of the motor according to the application and process requirements.

Features

The TeSys Tera system provides the following features:

- Configurable overload protection for class 5 to 40 based on current.
- Thermistor based motor protection.
- Imbalance, phase loss protection for current, and voltage input separately.
- Locked rotor or stalled rotor protection.
- Electrical parameter monitoring, such as current, voltage, power, power factor, frequency, harmonics, and energy.
- Monitoring for different motor based parameters, such as operating hours, number of starts, run hours, and so on.
- Communication with PLC or DCS over Modbus RTU, PROFIBUS DP, or EtherNet/IP protocol.
- Records trip data, event, self-diagnostic events with time stamp.
- Different starter configurations, such as overload, direct online (DOL), reverse direct online (RDOL), and star-delta.
- Independent protection, even if PLC or DCS connection is interrupted, TeSys Tera system still provides protection for the motor.
- Flexible protection, control, and communication options to suit any low voltage contactor-controlled motor starter application.
- Integrated push button and LED indicators reduce external components and wiring.
- Multiple communication protocols allow affordable integration to larger and complex substation monitoring and control systems.
- Reset push button is available on the controller and the control operator unit thereby reducing the need for one digital input to be configured as reset.
- Optional graphical control operator unit is provided with the controller for display of all metering, protection, and related parameters.
- Conformal coating on the PCB inside the controller resists the corrosive environment, hazardous chemicals, dust, and so on.

Components of TeSys Tera System

The hardware components of the TeSys Tera system are:

- LTMT main unit
- LTMTCT/LTMTCTV sensor module
- LTMT expansion module
- LTMTCUF control operator unit

The microprocessor based LTMT main unit is the central component in the system that manages the control, protection, and monitoring functions of three-phase AC induction motors.

The LTMT main unit is designed to work with the following protocols:

- Modbus RTU

- PROFIBUS DP
- EtherNet/IP
- Modbus TCP/IP

The system can be configured and controlled by using the following interfaces:

- A PC running the TeSys Tera DTM embedded in a FDT container such as SoMove software.
- The LTMTCUF control operator unit
- A PLC or DCS connected to the system through the communication network.

The TeSys Tera DTM Library software V2.0.0 or above to be installed on PC for DTM configuration. For more details on DTM configuration, refer to the *TeSys Tera Motor Management System DTM Library Online Help Guide – DOCA0275EN*.

Naming Conventions of LTMT Main Unit

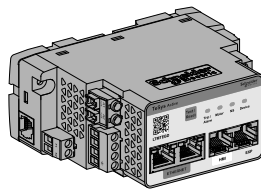

The reference number of the LTMT main unit is based on the communication protocol and control voltage of the controller.

The following tables describe the LTMT main unit reference number: LTMTxyy

x	Communication Protocol
E	Ethernet (Modbus TCP/IP and EtherNet/IP)
M	Modbus SL
P	PROFIBUS DP

yy	Control Voltage
BD	24 Vdc
FM	100–240 Vac/Vdc

Naming Conventions of LTMTCT/LTMTCTV Horizontal Sensor Module

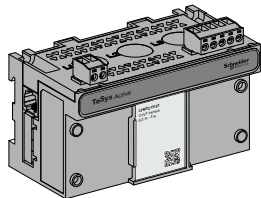

The reference number of the LTMTCT/LTMTCTV sensor module is based on the ampere rating and applicable zone of the sensor module.

The following tables describe the LTMTCT/LTMTCTV sensor module reference number: LTMTCTxxyy, LTMTCTxxxxy, LTMTCTVxxyy, or LTMTCTVxxxxy

xx\xxx	Ampere Rating
3	0.3 to 3 A
25	2.5 to 25 A
100	10 to 100 A

yy	Applicable Zone
T	IEC
UT	UL

Naming Conventions of LTMT Expansion Unit

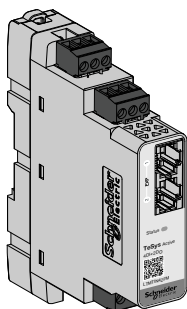

The reference number of the LTMT expansion module is based on digital input and output.

The following tables describe the LTMT expansion module reference number: LTMTxxyzz

xx	Type of Input/Output
IN	Digital Input/Output
AN	Analog Input/Output

yy	Number of Input/Output
42	4 Input, 2 Output
21	2 Input, 1 Output

zz	Control Voltage
BD	24 Vdc
FM	100–240 Vac/Vdc

Components such as the control operator unit, load external transformers, ground current sensors, and cables add additional range to the TeSys Tera system.

The TeSys Tera system is configured and controlled by SoMove software, which is a Microsoft Windows® based application, using the open FDT/DTM technology.

SoMove software contains many DTM libraries. A specific DTM library exists for the TeSys Tera Motor Management System.

TeSys T to TeSys Tera Substitution

What's in This Part

TeSys T to TeSys Tera Commercial References 20
Physical Device Replacement 22
Equivalent Starter Types or Operating Modes 31
Equivalent Data Addresses 32

TeSys T to TeSys Tera Commercial References

Equivalent Commercial References

The TeSys T system has the maximum capacity of equipping the LTMR controller with one LTME expansion module at a time. Whereas, the TeSys Tera system has the maximum capacity of equipping the LTMT main unit with one LTMTCT/ LTMTCTV sensor module and up to five LTMT expansion modules.

The following protocols are supported by the TeSys Tera system for migration from TeSys T system:

- Modbus RTU
- PROFIBUS DP
- EtherNet/IP
- Modbus TCP/IP

The following protocols are not supported by the TeSys Tera system and cannot be migrated from TeSys T system:

- CANopen
- DeviceNet

The following table contains equivalent commercial reference numbers and combinations of the LTMT main unit and LTMT expansion modules that are suitable for replacing the TeSys T system:

TeSys T	TeSys Tera		
Main Controller	Main Unit	Sensor Module	Expansion Unit 1
LTMR08MBD	LTMTMBD	Refer to the table below for the suitable LTMTCT/LTMTCTV sensor module to be added with the LTMT main unit.	LTMTIN42BD
LTMR08MFM	LTMTMFM		LTMTIN42FM
LTMR08PBD	LTMTPBD		LTMTIN42BD
LTMR08PFM	LTMTPFM		LTMTIN42FM
LTMR08EBD	LTMTEBD		LTMTIN42BD
LTMR08EFM	LTMTEFM		LTMTIN42FM
LTMR27MBD	LTMTMBD		LTMTIN42BD
LTMR27MFM	LTMTMFM		LTMTIN42FM
LTMR27PBD	LTMTPBD		LTMTIN42BD
LTMR27PFM	LTMTPFM		LTMTIN42FM
LTMR27EBD	LTMTEBD		LTMTIN42BD
LTMR27EFM	LTMTEFM		LTMTIN42FM
LTMR100MBD	LTMTMBD		LTMTIN42BD
LTMR100MFM	LTMTMFM		LTMTIN42FM
LTMR100PBD	LTMTPBD		LTMTIN42BD
LTMR100PFM	LTMTPFM		LTMTIN42FM
LTMR100EBD	LTMTEBD		LTMTIN42BD
LTMR100EFM	LTMTEFM		LTMTIN42FM

TeSys T		TeSys Tera			
Main Controller	Expansion Module	Main Unit	Sensor Module	Expansion Unit 1	Expansion Unit 2
LTMR08MBD	LTMEV40BD	LTMTMBD	Refer to the table below for the suitable LTMTCT/ LTMTCTV sensor module to be added with the LTMT main unit.	LTMTIN42BD	LTMTIN42BD
LTMR08MFM	LTMEV40FM	LTMTMFM		LTMTIN42FM	LTMTIN42FM
LTMR08PBD	LTMEV40BD	LTMTTPBD		LTMTIN42BD	LTMTIN42BD
LTMR08PFM	LTMEV40FM	LTMTPFM		LTMTIN42FM	LTMTIN42FM
LTMR08EBD	LTMEV40BD	LTMTTEBD		LTMTIN42BD	LTMTIN42BD
LTMR08EFM	LTMEV40FM	LTMTTEFM		LTMTIN42FM	LTMTIN42FM
LTMR27MBD	LTMEV40BD	LTMTMBD		LTMTIN42BD	LTMTIN42BD
LTMR27MFM	LTMEV40FM	LTMTMFM		LTMTIN42FM	LTMTIN42FM
LTMR27PBD	LTMEV40BD	LTMTTPBD		LTMTIN42BD	LTMTIN42BD
LTMR27PFM	LTMEV40FM	LTMTPFM		LTMTIN42FM	LTMTIN42FM
LTMR27EBD	LTMEV40BD	LTMTTEBD		LTMTIN42BD	LTMTIN42BD
LTMR27EFM	LTMEV40FM	LTMTTEFM		LTMTIN42FM	LTMTIN42FM
LTMR100MBD	LTMEV40BD	LTMTMBD		LTMTIN42BD	LTMTIN42BD
LTMR100MFM	LTMEV40FM	LTMTMFM		LTMTIN42FM	LTMTIN42FM
LTMR100PBD	LTMEV40BD	LTMTTPBD		LTMTIN42BD	LTMTIN42BD
LTMR100PFM	LTMEV40FM	LTMTPFM		LTMTIN42FM	LTMTIN42FM
LTMR100EBD	LTMEV40BD	LTMTTEBD		LTMTIN42BD	LTMTIN42BD
LTMR100EFM	LTMEV40FM	LTMTTEFM		LTMTIN42FM	LTMTIN42FM

LTMTCT/LTMTCTV Sensor Modules

The following table contains commercial reference numbers and combinations of the LTMTCT/LTMTCTV sensor modules, which are suitable for replacing the TeSys T system:

Motor Full Load Current Value	Reference
0.3 to 3 A	LTMTCT3T
	LTMTCTV3T
	LTMTCTV3UT
2.5 to 25 A	LTMTCT25T
	LTMTCTV25T
	LTMTCTV25UT
10 to 100 A	LTMTCT100T
	LTMTCTV100T
	LTMTCTV100UT

Physical Device Replacement

Overview

This chapter provides information about the physical device replacement of TeSys T system to TeSys Tera system.

The physical marking of the terminals are available on all the modules of the TeSys T system and TeSys Tera system.

NOTE: The replacement of the TeSys T by the TeSys Tera has to be carried out only as a whole system and not as individual modules or devices.

For more details about the wiring and physical replacement or installation of the system, contact Schneider Electric or refer to *TeSys Tera Motor Management System Installation Guide – DOCA0356EN*.

For installation of the TeSys Tera system in an Okken switchboard, refer to *Okken Communications Cabling and Wiring Guide* (available on request).

For installation of the TeSys Tera system in a Blokset switchboard, refer to *Blokset Communications Cabling and Wiring Guide* (available on request).

For installation of the TeSys Tera system in a Model 6 switchboard, refer to *Model 6 Communications Cabling and Wiring Guide* (available on request).

NOTE: To obtain the above documents, contact Schneider Electric.

TeSys T to TeSys Tera Conversion:

Control Wiring

The following tables describe the terminal conversion from the TeSys T system to the TeSys Tera system.

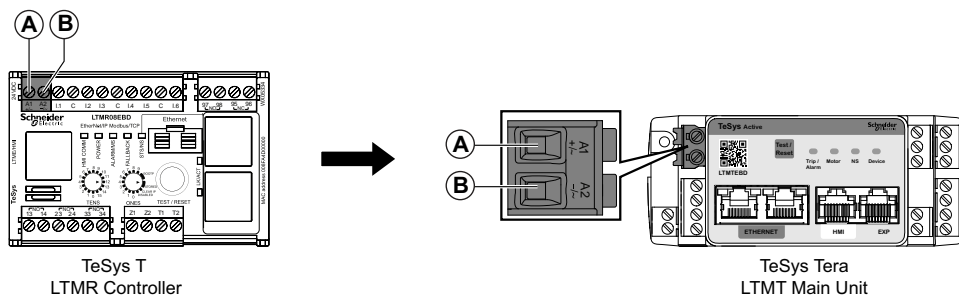

Terminal Category	Legend	TeSys T	TeSys Tera
		LTMR controller	LTMT main unit
Power supply	A	A1	A1 ~/-
	B	A2	A2 ~/+

Digital Input Supply

⚠ WARNING

UNINTENDED MACHINE OPERATION

- TeSys T digital inputs in the LTMRXFM series support 110-230 Vac and TeSys Tera LTMT main unit does not support 230 Vac digital inputs, it supports only 24 Vdc.
- Use proper interposing relay between 230 Vac and 24 Vdc.

Failure to follow these instructions can result in death, serious injury, or equipment damage.

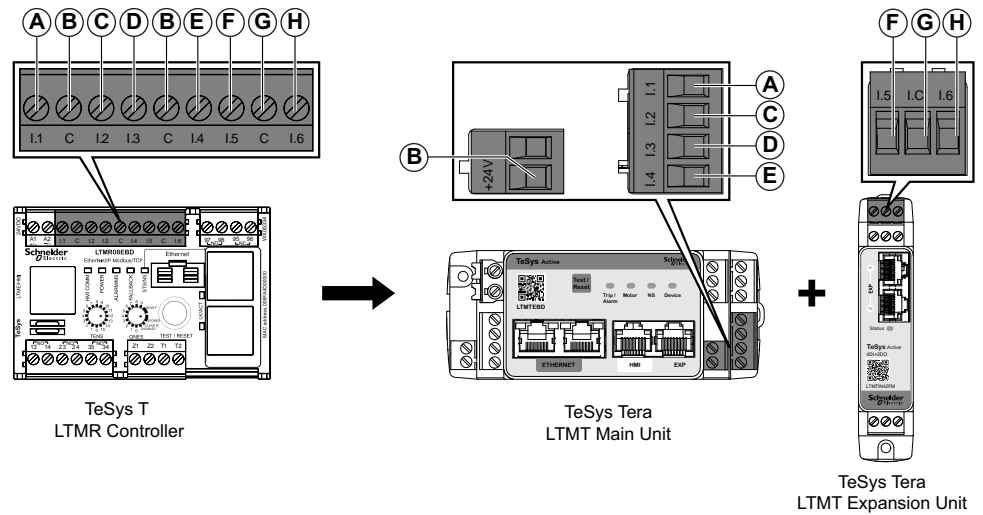

Terminal Category	Legend	TeSys T	TeSys Tera	
		LTMR controller	LTMT main unit	LTMT expansion module LTMTIN42FM or LTMTIN42BD
Digital input	A	I.1	I.1	
	B	C	+24V	
		C		
	C	I.2	I.2	
	D	I.3	I.3	
	E	I.4	I.4	
	F	I.5		I.5
	B	C		I.C
H	I.6		I.6	

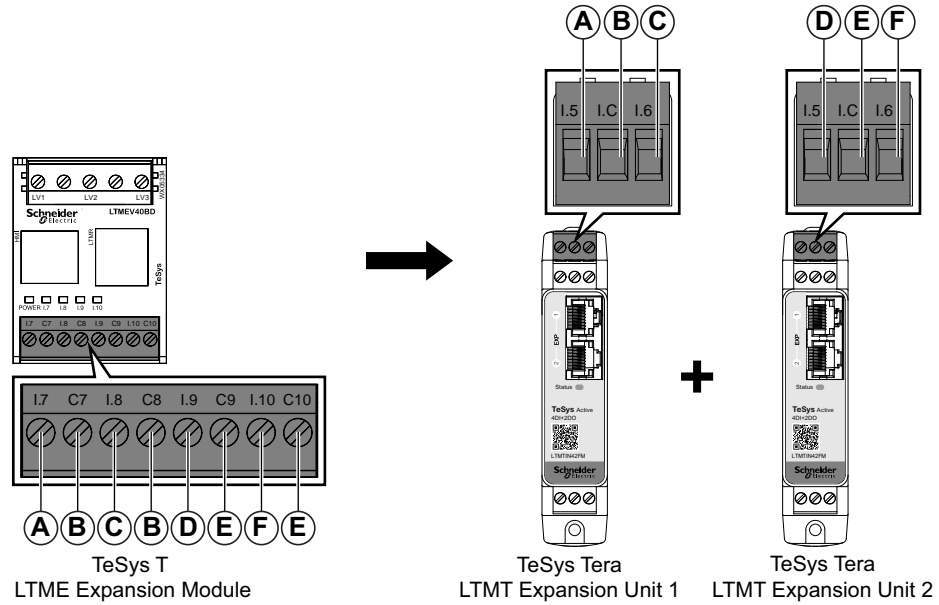

Terminal Category	Legend	TeSys T		
		LTME expansion module	LTMT expansion module 1 LTMTIN42FM or LTMTIN42BD	LTMT expansion module 2 LTMTIN42FM or LTMTIN42BD
Digital input	A	I.7	I.7	
	B	C7	I.C	
		C8		
	C	I.8	I.8	
	D	I.9		I.5
	E	C9		I.C
C10				
F	I.10		I.6	

Digital Output Supply

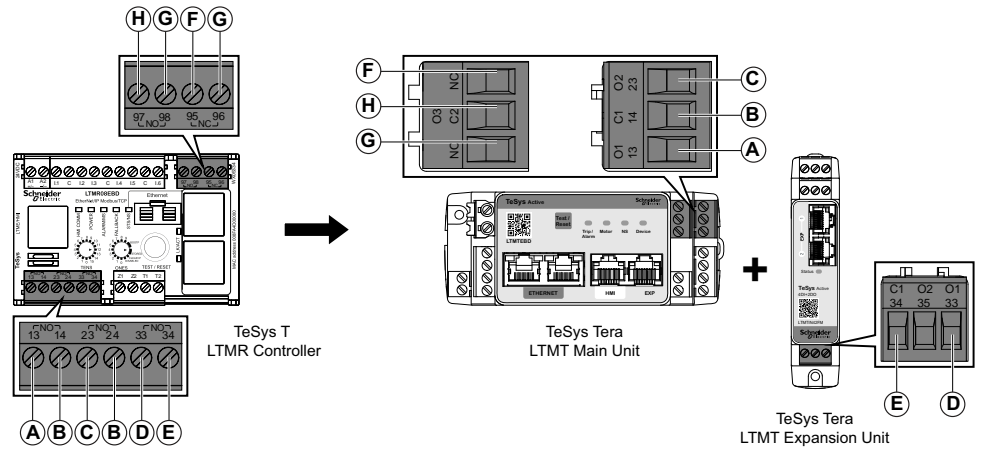

Terminal Category	Legend	TeSys T	TeSys Tera	
		LTMR controller	LTMT main unit	LTMT expansion module LTMTIN42FM or LTMTIN42BD
Digital output	A	13	O1 13	
	B	14	C1 14	
	B	24	C1 14	
	C	23	O2 23	
	D	33		O1 33
	E	34		C1 34
	F	95	NC	
	G	96	—	
	H	97	O3 C2	
	G	98	NO	

Temperature Input Wiring

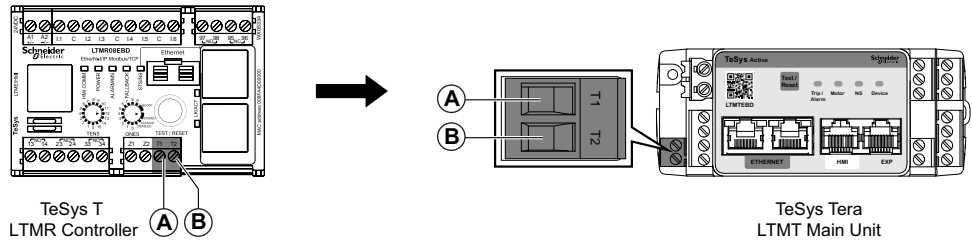

Terminal Category	Legend	TeSys T	TeSys Tera
		LTMR controller	LTMT main unit
Temperature input	A	T1	T1
	B	T2	T2

Communication Wiring

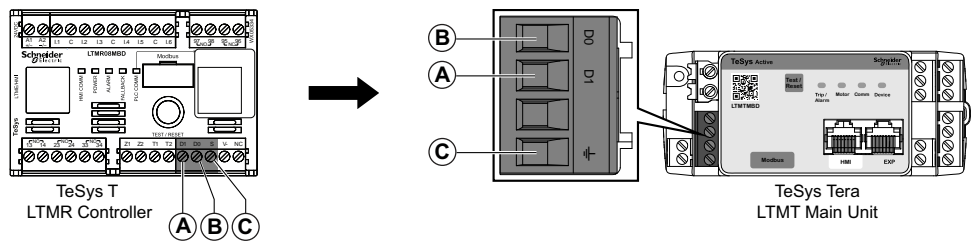

Terminal Category	Legend	Type of communication	TeSys T	TeSys Tera
			LTMR controller	LTMT main unit
Communication	A	Modbus	D1	D1
	B		D0	D0
	C		S	⊥

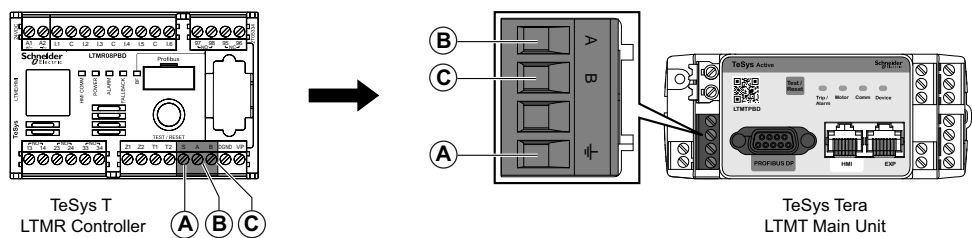

Terminal Category	Legend	Type of communication	TeSys T	TeSys Tera
			LTMR controller	LTMT main unit
Communication	A	PROFIBUS DP	S	⊥
	B		A	A
	C		B	B

NOTE: You can use side connector or sub-D9 connector for PROFIBUS DP communication. For more information, refer *TeSys Tera Motor Management System PROFIBUS DP Communication Guide – DOCA0256EN*.

Earth Leakage Wiring

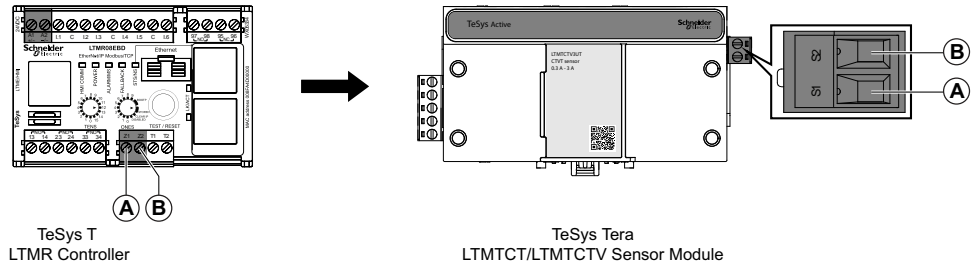

Terminal Category	Legend	TeSys T	
		LTMR controller	LTMTCT/LTMTCTV sensor module
Earth leakage	A	Z1	S1
	B	Z2	S2

Voltage Input Wiring

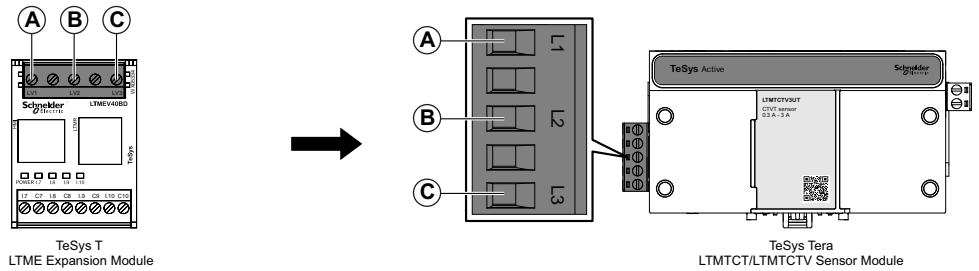

Terminal Category	Legend	TeSys T	
		LTME expansion module	LTMTCT/LTMTCTV sensor module
Voltage input	A	LV1	L1
	B	LV2	L2
	C	LV3	L3

NOTE: The listed sensors are valid for use with the LTMTCTV••T or LTMTCTV••UT horizontal sensor module.

Cables

The following table describe the cables to be used for the migration from TeSys T system to TeSys Tera system:

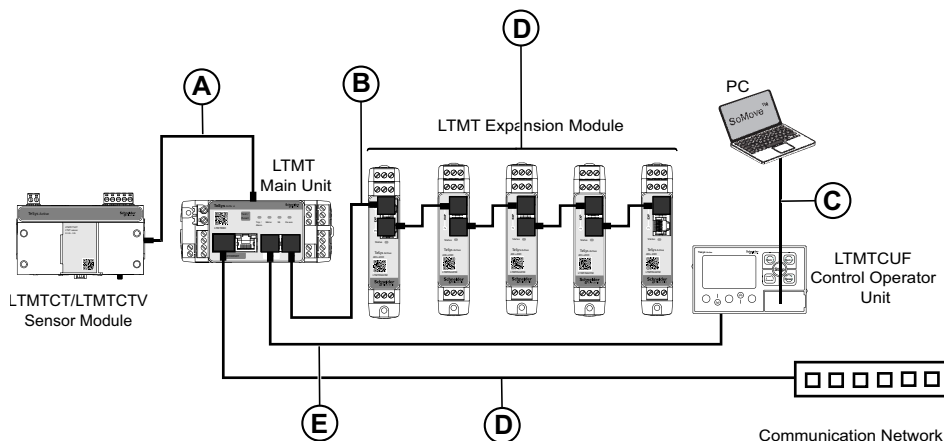

Legend	Connection to	TeSys T system		TeSys Tera system	
		Description	Reference	Description	Reference
A	Sensor module	Connecting jumper 0.04 m (1.57 in.) length, for side by side connection of the LTMR and LTME	-	LTMT main unit to LTMTCT/LTMTCTV sensor module RJ11 connector cable 0.15 m (5.9 in) length.	LTMT9RJ1015
				LTMT main unit to LTMTCT/LTMTCTV sensor module RJ11 connector cable 0.5 m (19.7 in) length.	LTMT9RJ105
				LTMT main unit to LTMTCT/LTMTCTV sensor module RJ11 connector cable 0.2 m (7.87 in) length.	LTMT9RJ102
B	Expansion unit	LTMR to LTME RJ45 connector cable 0.3 m (11.81 in.) length	LTM9CEXP03	LTMT main unit to LTMT expansion module RJ45 connector cable 0.1 m (3.9 in) length.	LTMT9RJ401
		LTMR to LTME RJ45 connector cable 1.0 m (3.28 ft) length	LTM9CEXP10	LTMT expansion module to LTMT expansion module RJ45 connector cable 0.1 m (3.9 in) length.	LTMT9EX10
E	HMI	—	—	LTMT main unit to LTMTCUF control operator unit connection cable 1.0 m (39.3 in) length.	LTM9CU10S
				LTMT main unit to LTMTCUF control operator unit connection cable 3.0 m (118.1 in) length.	LTM9CU30S

The following table describe the common cables used in TeSys T system and TeSys Tera system:

Legend	Connection to	Description	Reference
C	PC	Cable kit, includes LTME/LTMR/LTMCU to PC communication cable 2.5 m (98.4 in) length	TCSMCNAM3M002P
D	EtherNet/IP network	Category 5 shielded/unshielded twisted-pair network connection cables with two RJ45 connectors	490 NTW 000 ...
		Modbus RTU network communication cable 0.3 m (11.81 in) length.	VW3A8306R03
		Modbus RTU network communication cable 1.0 m (39.3 in) length.	VW3A8306R10
		Modbus RTU network communication cable 3.0 m (118.1 in) length.	VW3A8306R30

Legend	Connection to	Description	Reference
	PROFIBUS DP network	PROFIBUS DP network communication cable 100 m (328.08 ft) length.	TSXPBSCA100
		PROFIBUS DP network communication cable 400 m (1,312.33 ft) length.	TSXPBSCA400

HMI Unit

The TeSys Tera system uses LTMTCUF control operator unit as the local HMI (Human Machine Interface).

NOTE:

The Control Operator Unit used in the TeSys T system is not compatible with the TeSys Tera system and should be replaced.

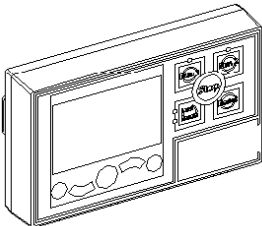
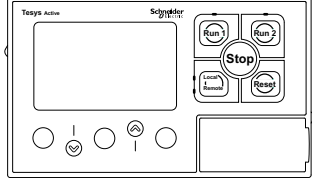
TeSys T system		TeSys Tera system	
Control operator unit	Reference	LTMTCUF control operator unit	Reference
	LTMCU (HMI device)		LTMTCUF
	LTMCUF (HMI device with FDR service)		
	LTM9CU•0 (HMI communication cable)		
	TCSMCNAM3M002P (cable kit)		
	LTM9KCU (Kit for portable LTMCU)		

Dimensions

<p>TeSys T system</p> <p>LTMR controller</p>	<p>TeSys Tera system</p> <p>LTMT main unit with LTMTCT/LTMTCTV sensor module Front View</p> <p>LTMT main unit with LTMTCT/LTMTCTV sensor module Side View</p>	
<p>LTME expansion module</p>	<p>LTMT expansion module Front view</p>	<p>LTMT expansion module Side view</p>

Equivalent Starter Types or Operating Modes

Overview

This chapter provides you with a list of starter types or operating modes that are equivalent and can be substituted from TeSys T to TeSys Tera.

List of Equivalent Starter Types or Operating Modes

TeSys T	TeSys Tera
Overload	Overload
Independent	Direct Online
Reverser	Reverse Direct Online
Two-Step	Star Delta
Two-Speed	Dahlander/Pole Changing (Available in the future releases)
Custom	Custom Logic

NOTE: TeSys Tera offers additional starter types or operating modes other than the equivalent starter types or operating modes of TeSys T. To know more about the equivalent and additional starter types or operating modes, refer to *TeSys Tera Motor Management System User Guide – DOCA0257EN*.

Equivalent Data Addresses

What's in This Chapter

Equivalent Modbus Data Addresses	33
Equivalent EtherNet/IP Data Addresses	39

Overview

This chapter provides information about the equivalent data addresses to be used for performing the required functions after replacing the TeSys T system with the TeSys Tera system.

The equivalent data addresses are categorized into three sections as listed below:

- Data addresses similar between TeSys T and TeSys Tera
- Data addresses dissimilar between TeSys T and TeSys Tera
- Data addresses not available in TeSys Tera

Equivalent Modbus Data Addresses

Modbus Addresses Similar Between TeSys T and TeSys Tera

Data addresses that are similar between TeSys T and TeSys Tera are listed in the table below:

Data Address in TeSys T	Parameter
123	Alarm count
124-125	Motor LO1 closing count
126-127	Motor LO2 closing count
150-179	Last trip statistics
180-209	Trip n-1 statistics
210-239	Trip n-2 statistics
240-269	Trip n-3 statistics
270-299	Trip n-4 statistics
300-329	Last trip extension
330-359	Trip n-1 extension
360-389	Trip n-2 extension
390-419	Trip n-3 extension
420-449	Trip n-4 extension
450	Minimum wait time
451 ⁽¹⁾	Trip code
452	Trip register 1
453	Trip register 2
454	Trip register 3
455	System status register 1
456	System status register 2
457	Digital input
458	Digital output
459	Reserved
460	Alarm code
461	Alarm register 1
462	Alarm register 2

⁽¹⁾ For more information on Trip code, refer *TeSys Tera Motor Management System User Guide – DOCA0257EN*.

Data Address in TeSys T	Parameter
463	Alarm register 3
464	Motor temperature sensor degree
465	Thermal capacity level
466	Average current ratio
467	L1 current ratio
468	L2 current ratio
469	L3 current ratio
470	Ground current ratio
471	Current phase imbalance
601.0	Entry and exit configuration
602.11	HMI motor LED status
800–899	User map addresses
900–999	User map values
1202	Custom logic memory space
1203	Custom logic memory used
1204	Custom logic temporary space
1205	Custom logic non-volatile space
1250	Custom logic setting register 1
1270	Custom logic command register 1
1280	Custom logic monitoring register 1
1301-1399	Custom logic general purpose registers

Modbus Addresses Dissimilar Between TeSys T and TeSys Tera

Data addresses that are dissimilar between TeSys T and TeSys Tera are listed in the table below:

Data Address in TeSys T	Parameter in TeSys T	Data Address in TeSys Tera	Parameter in TeSys Tera
35-40	Expansion commercial reference	9218	LTMT expansion module 1 type
		9219	LTMT expansion module 2 type
		9220	LTMT expansion module 3 type
		9221	LTMT expansion module 4 type
		9222	LTMT expansion module 5 type
47	Expansion firmware version	9182–9183	LTMT expansion module 1 firmware version
		9188–9189	LTMT expansion module 2 firmware version
		9194–9195	LTMT expansion module 3 firmware version
		9200–9201	LTMT expansion module 4 firmware version
		9206–9207	LTMT expansion module 5 firmware version
64-69	Controller commercial reference	9152–9161	Commercial reference
70-74	Controller serial number	9127–9142	Product serial number

Data Address in TeSys T	Parameter in TeSys T	Data Address in TeSys Tera	Parameter in TeSys Tera
76	Controller firmware version	9164–9165	LTMT main unit firmware version
102	Ground current faults count	5764	Calculated ground trip counter
		5765	Measured ground trip counter
103	Thermal overload faults count	5758	Thermal overload trip counter
104	Long start faults count	5777	Ethernet module firmware side removed
105	Jam faults count	5759	Locked rotor trip counter
		5760	Stalled rotor trip counter
106	Current phase imbalance faults count	5767	Current imbalance trip counter
107	Undercurrent faults count	5766	Phase under current trip counter
114	Network port faults count	5778	Communication loss trip counter
130	Overcurrent faults count	5761	Definite time overcurrent trip counter
		5762	Normal inverse overcurrent trip counter
131	Current phase loss faults count	5768	Current phase loss trip counter
132	Motor temperature sensor faults count	5779	LTMT main unit temperature trip counter
133	Voltage phase imbalance faults count	5773	Voltage imbalance trip counter
134	Voltage phase loss faults count	5772	Voltage phase loss trip counter
136	Undervoltage faults count	5770	Phase under voltage trip counter
137	Overvoltage faults count	5771	Phase over voltage trip counter
138	Underpower faults count	5780	Under power trip counter
139	Overpower faults count	5781	Over power trip counter
140	Under power factor faults count	5782	Under power factor trip counter
475	Motor temperature sensor (x 0.1 Ω)	5551	Temperature measured by binary PTC sensor in Ohm
476	Average voltage (V)	5520	Average voltage
477	L3-L1 voltage (V)	5518	L3-L1 RMS voltage
478	L1-L2 voltage (V)	5514	L1-L2 RMS voltage
479	L2-L3 voltage (V)	5516	L2-L3 RMS voltage
480	Voltage phase imbalance (%)	5522	Voltage imbalance
482	Active power (x 0.1 kW)	5526	Total active power
483	Reactive power (x 0.1 kVAR)	5528	Total reactive power
491	Network port baud rate	4395	Modbus settings - Baud Rate
493	Network port parity	4394	Modbus settings - Parity
510	Controller port ID	4393	Modbus settings - Node Address
511	Time to trip (x 1 s)	5559	Motor data - Thermal Time to Trip
513	Motor last start duration (s)	5572	Motor data - Last Run Hour

Data Address in TeSys T	Parameter in TeSys T	Data Address in TeSys Tera	Parameter in TeSys Tera
514	Motor starts per hour count	5563	Max starts counter/Max starts per hour counter
540	Motor operating mode	4421	Starter settings - Starter Type
541	Motor transition timeout	4443	Starter settings - Delay 2 Changeover time
549	Motor temperature sensor fault threshold (x 0.1 Ω)	3791	PTC pickup
551	Motor temperature sensor fault threshold degree ($^{\circ}\text{C}$)	3790	PT100 pickup ($^{\circ}\text{C}$ or F)
552	Motor temperature sensor warning threshold degree ($^{\circ}\text{C}$)	3794	PT100 alarm level ($^{\circ}\text{C}$ or F)
555	Current phase loss timeout (x 0.1 s)	3582	Current phase loss — Time Delay
556	Overcurrent fault timeout (s)	3532	Time delay during motor start (T_{pS})
		3533	Time delay during motor run (T_{pR})
557	Overcurrent fault threshold (% FLC)	3531	Definite time overcurrent - Pickup
558	Overcurrent warning threshold (% FLC)	3534	Definite time overcurrent - Alarm Level
562	External ground current fault timeout (x 0.01 s)	3561	Measured ground fault - Time Delay
563	External ground current fault threshold (x 0.01 A)	3560	Measured ground fault - Pickup
564	External ground current warning threshold (x 0.01 A)	3562	Measured ground fault - Alarm Level
565	Motor nominal voltage (V)	4461	Nominal voltage (V_n)
566	Voltage phase imbalance fault timeout starting (x 0.1 s)	3647	Voltage imbalance - Time Delay
568	Voltage phase imbalance fault threshold (% imb)	3646	Voltage imbalance - Pickup
569	Voltage phase imbalance warning threshold (% imb)	3648	Voltage imbalance - Alarm Level
570	Overvoltage fault timeout (x 0.1 s)	3635	Phase over voltage - Time Delay
571	Overvoltage fault threshold (% V_{nom})	3634	Phase over voltage - Pickup
572	Overvoltage warning threshold (% V_{nom})	3636	Phase over voltage - Alarm Level
573	Undervoltage fault timeout	3627	Phase under voltage - Time Delay
574	Undervoltage fault threshold (% V_{nom})	3626	Phase under voltage - Pickup
575	Undervoltage warning threshold (% V_{nom})	3628	Phase under voltage - Alarm Level
576	Voltage phase loss fault timeout (x 0.1 s)	3641	Voltage phase loss - Time Delay
577	Voltage dip setting	3757	Voltage dip - Function Setting

Data Address in TeSys T	Parameter in TeSys T	Data Address in TeSys Tera	Parameter in TeSys Tera
578	Load shedding timeout (s)	3764	Voltage dip - Load Shedding Timeout
579	Voltage dip threshold (% Vnom)	3758	Voltage dip
580	Voltage dip restart timeout (s)	3760	Voltage dip restart timeout
581	Voltage dip restart threshold (% Vnom)	3759	Voltage restoration
582	Auto restart immediate timeout (x 0.1 s)	3763	Voltage dip - Immediate Restart Timeout
583	Motor nominal power (x 0.1 kW)	4481	Nominal power (KW)
584	Overpower fault timeout (s)	3680	Over power - Time Delay
585	Overpower fault threshold (% Pnom)	3679	Over power - Pickup
586	Overpower warning threshold (% Pnom)	3681	Over power - Alarm Level
587	Underpower fault timeout (s)	3673	Under power - Time Delay
588	Underpower fault threshold (% Pnom)	3672	Under power - Pickup
589	Underpower warning threshold (% Pnom)	3674	Under power - Alarm Level
590	Under power factor fault timeout (x 0.1 s)	3687	Under power factor - Time Delay
591	Under power factor fault threshold (x 0.01 PF)	3686	Under power factor - Pickup
592	Under power factor warning threshold (x 0.01 PF)	3688	Under power factor - Alarm Level
596	Auto restart delayed timeout (s)	3761	Voltage dip - Delayed Restart Timeout
603	HMI port address setting	4399	LTMT HMI port settings - Node Address
604	HMI port baud rate setting (Baud)	4401	LTMT HMI port settings - Baud Rate
606	Motor trip class (s)	3502	Thermal overload — Trip Class
608	Thermal overload fault reset threshold (% trip level)	3505	Thermal reset level
609	Thermal overload warning threshold (% trip level)	3503	Thermal overload - Alarm Level
610	Internal ground current fault timeout (x 0.1 s)	3554	Calculated ground fault - Time Delay
611	Internal ground current fault threshold (% FLCmin)	3553	Calculated ground fault - Pickup
612	Internal ground current warning threshold (% FLCmin)	3555	Calculated ground fault - Alarm Level
613	Current phase imbalance fault timeout starting (x 0.1 s)	3576	Current imbalance - Time Delay

Data Address in TeSys T	Parameter in TeSys T	Data Address in TeSys Tera	Parameter in TeSys Tera
615	Current phase imbalance fault threshold (% imb)	3575	Current imbalance - Pickup
616	Current phase imbalance warning threshold (% imb)	3577	Current imbalance - Alarm Level
617	Jam fault timeout (s)	3526	Locked rotor - Time Delay
618	Jam fault threshold (% FLC)	3525	Locked rotor - Pickup
619	Jam warning threshold (% FLC)	3527	Locked rotor - Alarm Level
620	Undercurrent fault timeout (s)	3568	Phase under current - Time Delay
621	Undercurrent fault threshold (% FLC)	3567	Phase under current - Pickup
622	Undercurrent warning threshold (% FLC)	3569	Phase under current - Alarm Level
623	Long start fault timeout (s)	3751	Excessive start time — Time Delay
624	Long start fault threshold (% FLC)	3754	Excessive start — Run Threshold
628	Load CT primary	4452	System settings - Phase CT Primary
629	Load CT secondary	4453	System settings - Phase CT Secondary
630	Load CT multiple passes (passes)	4468	System settings - Phase CT Secondary Passes
652	Motor full load current ratio, FLC1 (% FLCmax)	4466	System settings - Full Load Current (FLC1)
653	Motor high speed full load current ratio, FLC2 (% FLCmax)	4467	System settings - Speed 2 Full Load Current (FLC2)
693	Network port comm loss timeout (x 0.01 s) (Modbus only)	4397	Modbus settings - Timeout
694	Network port parity setting (Modbus only)	4394	Modbus settings - Parity
695	Network port baud rate setting (Baud)	4395	Modbus settings - Baud Rate
696	Network port address setting	4393	Modbus settings - Node Address
700	Register available to remotely write commands that can be processed in a Custom Logic	700	T parameters - Permissive Command Data
704	Control register 1	704	Command data 1
705	Control register 2	705	Command data 2

Equivalent EtherNet/IP Data Addresses

For EtherNet/IP the data is available at the same objects as TeSys T. For more details about the TeSys Tera implementation, refer *TeSys Tera Motor Management System EtherNet/IP Communication Guide - DOCA0258EN*.

Functionality Difference Between TeSys T System and TeSys Tera System

This section provides information about the functionality difference between TeSys T system and TeSys Tera system.

- In the TeSys T system, only I3 input can be configured as an interlock, whereas in the TeSys Tera system, any input can be configured as an interlock.
- In the TeSys T system, the reference voltage between common and digital input is depends on module reference (LTMRXFM is 230 Vac and LTMRXBD is 24 Vdc), whereas in the TeSys Tera system the reference digital input voltage is 24 Vdc.

Schneider Electric
35 rue Joseph Monier
92500 Rueil Malmaison
France

+ 33 (0) 1 41 29 70 00

www.se.com

As standards, specifications, and design change from time to time, please ask for confirmation of the information given in this publication.

© 2026 – Schneider Electric. All rights reserved.

DOCA0278EN-00